

SPILLGUARD[™]

Effortless spill prevention
for 1/2" - 2" AODD Pumps

Why risk downtime, lost product, or expensive cleanup? SPILLGUARD gives your existing equipment an added layer of protection in a compact and lightweight package (under 10lbs).



WHY SPILLGUARD?

- Essential spill prevention
- Automatic pump shutoff
- Compact, simple design
- Designed for 1/2" - 2" AODD pumps
- Mounts directly to your pump
- Optional stand available
- Factory set regulator
- Pump shutoff valve included
- Simple to replace

Provides
**automatic pump
shutdown and spill
containment during
diaphragm failure.**

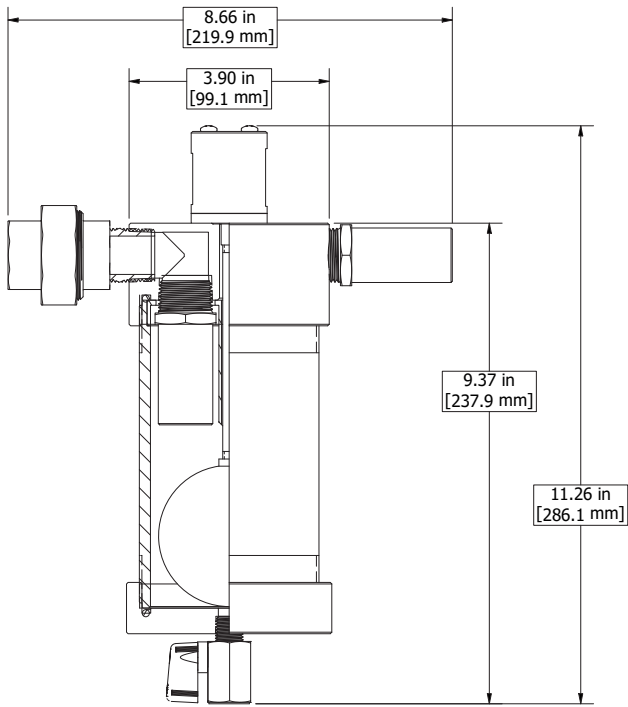

SGD-02
(direct-to-pump)

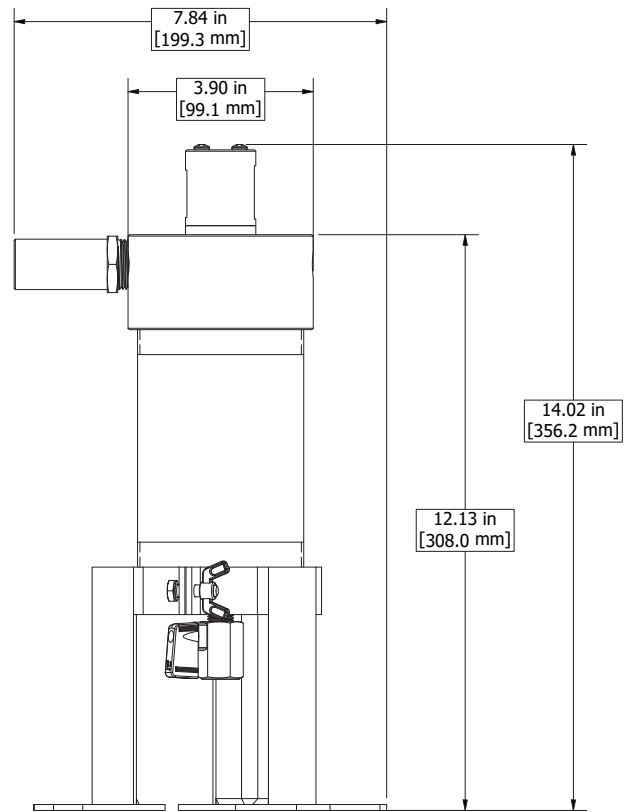

SGD-02-S
(with stand)



SPECIFICATIONS

BODY MATERIAL: Aluminum

INTERNAL COMPONENTS: Polypropylene

INTERNAL FLOAT: Stainless Steel

WEIGHT: 9lbs (4.1kg)

PUMP SIZE/TYPE: 0.5"-2" AODD

INLET SIZE: 0.75" (20mm)

INLET TYPE: FNPT, Union

MAX DISCHARGE PRESSURE: 120 psi (8.27 bar)

AIR SUPPLY: 50 psi (3.5 bar) minimum

(Factory-set regulator included)

ACCESSORIES: Exhaust shutoff valve for applications with positive inlet pressure

Optional stand available when direct mounting isn't possible