

Extend Bearing Life with Lubrication Oil Filtration Skids

Throwback meets innovation! We upgraded a lubrication skid design originally built by Anderson Process for Allis Chalmers back in the 70s. This modernized skid supplies lube oil to a large bearing in concrete production equipment. **We can design our skids to meet your specific lube oil ISO requirement to ensure longer bearing life.**

The system features:

- Haight internal gear pump
- Dynex high-pressure pump
- Dual Donaldson Hy-Pro filter housings

All mounted on a custom-fabricated c-channel base plate with carbon steel piping.

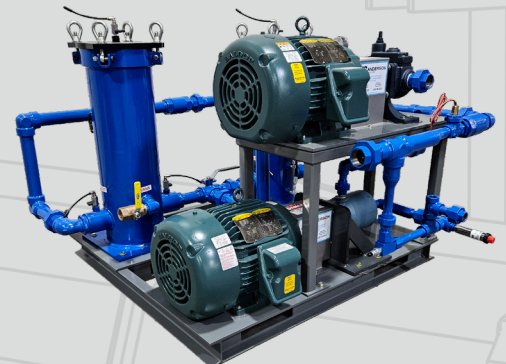
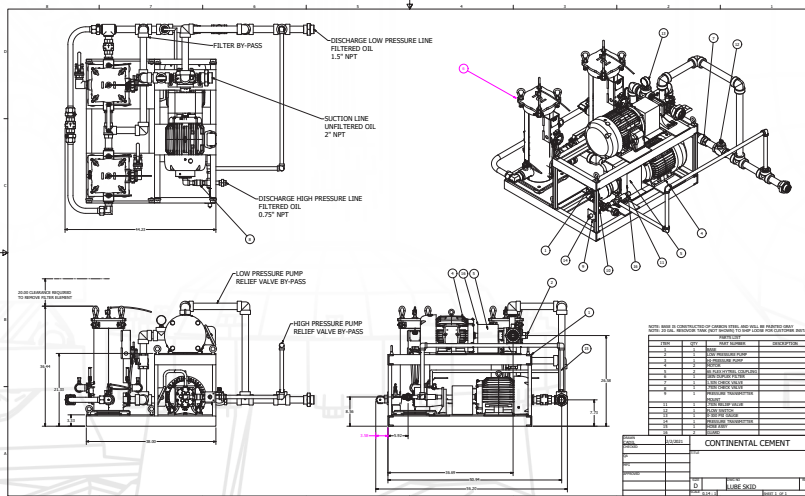

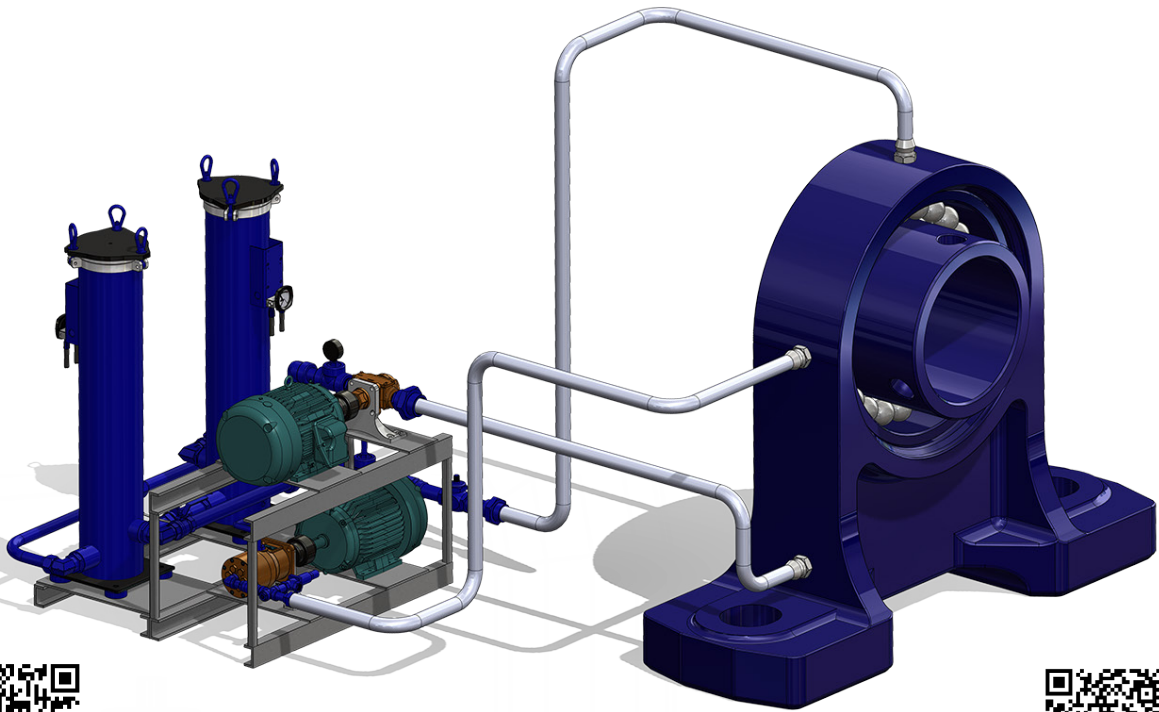

Corporate Capabilities
Brochure



Contact Us

Industries Served



Automotive



Biotech &
Pharmaceutical



Personal Care



Food & Beverage

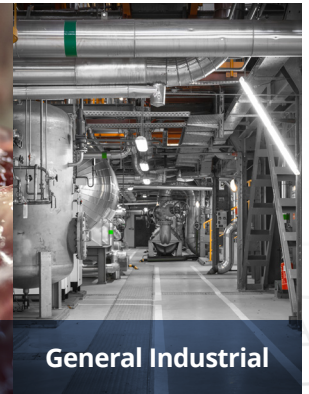

General Industrial



Chemicals,
Paints & Resins

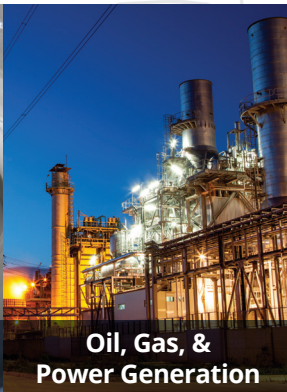

Oil, Gas, &
Power Generation



Data Centers



Pulp & Paper

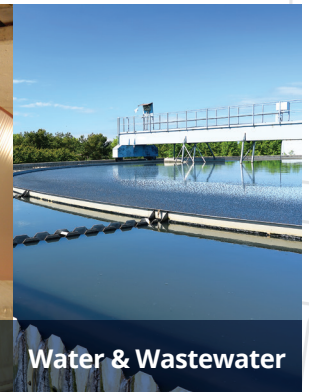

Water & Wastewater

Wisconsin Corporate
21365 Gateway Court
Brookfield, WI 53045
(262) 784-3340

Illinois Branch
960 Oak Creek Drive
Lombard, IL 60148
(630) 782-6834

Indiana Branch
8104 Woodland Drive
Indianapolis, IN 46278
(317) 875-6900

Michigan Branch
41304 Concept Drive
Plymouth, MI 48170
(248) 476-7782

Minnesota Branch
510 Sixth Street NW
New Prague, MN 56071
(248) 476-7782

Ohio Branch
4891 Van Epps Road
Brooklyn Heights, OH 44131
(216) 739-1600

AndersonProcess.com · Sales@AndersonProcess.com

Serving Illinois, Indiana, Iowa, Kentucky, Michigan, Minnesota, North Dakota, Ohio, South Dakota and Wisconsin