

# NETZSCH

Proven Excellence.

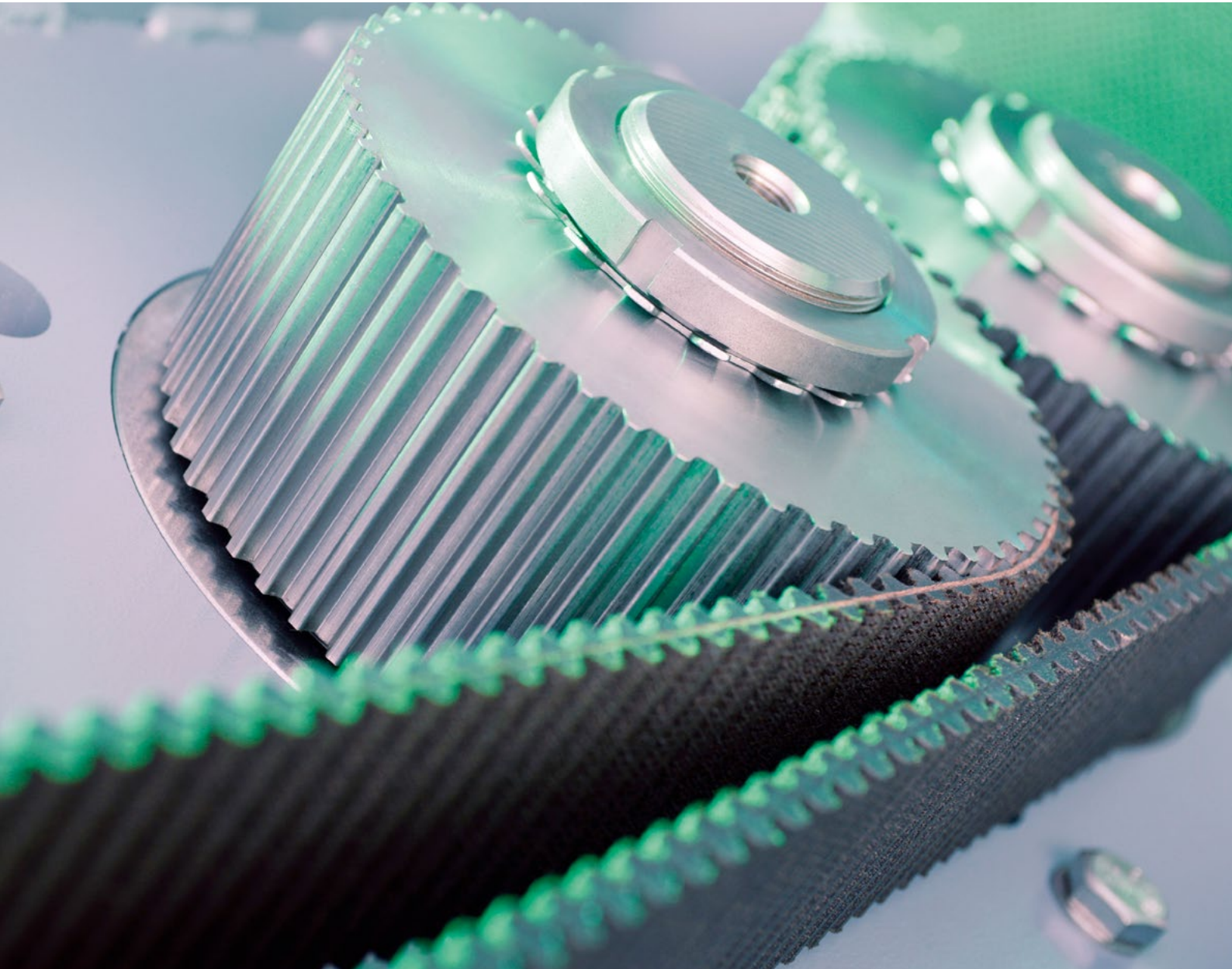

## TORNADO<sup>®</sup> Rotary Lobe Pumps

The service-friendly rotary lobe pump, constructed according to the principle of "full service in place"

Pumps & Systems

# TORNADO®

MAXIMUM SERVICE FRIENDLINESS MEETS HIGH PERFORMANCE

NETZSCH TORNADO® self-priming, valveless, positive displacement pumps can be optimally customised to meet specific process and application requirements. They can be used for almost any media on intermittent, continuous or dosing applications.

TORNADO® pumps are particularly service and maintenance friendly; all parts that come into contact with the media are directly accessible without dismantling the pipework or disconnecting the drive. Their advantages are small space requirements due to their compact design, high performance and maximised operational reliability, and the physical separation between the pump head and bearing housing.



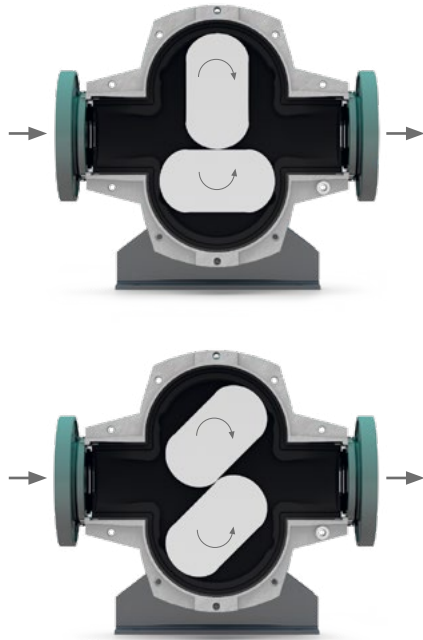

### Functioning principle

The TORNADO® rotary lobe pump is a positive displacement pump. The pumping action is generated by the contra-rotation of two rotors within the pump chamber which are synchronised externally. The media enters the pump chamber through the inlet port and is carried around the chamber by the rotors to the outlet port where it is discharged.

### Characteristics

- Valve free construction
- Self priming
- Suitable for any kind of liquid including media containing gas, solids or fibrous matter
- Suitable for lubricating and non lubricating media
- Pumping media with high or low viscosity
- Handling shear sensitive fluids
- Operating at temperature up to 100 °C
- Reversible operation
- Can be serviced without disconnecting pipework
- Tolerance of dry running

# The TORNADO® T2

REVOLUTIONARY IN DESIGN AND CUSTOMER BENEFIT

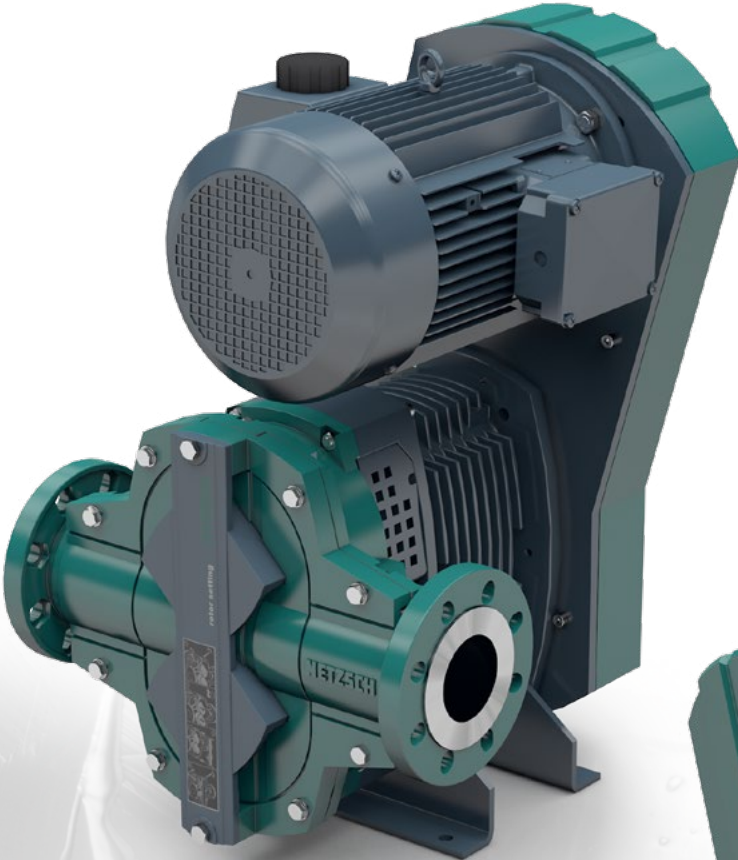

PROCESS OPTIMISATION

COMPACTNESS

RELIABLE



OPERATIONAL SAFETY

COST-EFFECTIVENESS

EASE OF SERVICE

MAINTENANCE-FREE

## Reliability

**“The best maintenance is no maintenance”**

We have perfected the rotary lobe pump concept by incorporating the tried, tested and proven NETZSCH core competence in the design and manufacture of engineered rubber solutions for the TORNADO® T2. During the entire pumping cycle only elastomer and metal component surfaces interface within the pump; elastomer to elastomer component surface interfaces, which suffer from excess wear and generate heat, are completely eliminated. Having these dissimilar materials for the static and dynamic pump head components, the elastomeric surfaces are subjected to a lower dynamic loading resulting in less plastic deformation and stress which in turn reduces wear and extends operational life. The use of high quality sealed for life bearings, selected for their load carrying characteristics and long life, combined with the tooth belt drive result in a drive train that can be considered maintenance-free.

## Ease of service

**“Full Service In Place instead of Maintenance In Place”**

The innovative design of the TORNADO® T2 provides quick and easy access to the pump chamber, including the inlet and outlet ports, by simply removing the cover plate. This provides improved access for inspection, cleaning, service and replacing parts.

## Compactness

**“Efficiency in the smallest space”**

The innovative design concept of incorporating a timing belt to synchronize and drive the pump means reduced space. The smaller overall dimensions and maintenance in place represent a cost saving in terms of site utilisation.

## Leakage protection

**“From GSS<sup>1</sup> to BSS<sup>2</sup>”**

The proven physical separation between pump chamber and bearing housing (GSS) guarantees absolute operational safety (BSS).

<sup>1</sup> GSS = Gearbox Security System

<sup>2</sup> BSS = Bearing Security System

## Environmental awareness

**“Green is already our corporate colour”**

The weight of the TORNADO® T2 has been significantly reduced through the choice of materials and innovative component design. This also means the pump consumes less energy. The reduced power requirement, in parallel with increased pump performance, lowers power consumption and so preserves our environment in a sustainable way. By eliminating the need for oil NETZSCH demonstrate their environmental awareness.

## Cost-effectiveness

**“Saves resources and saves money”**

The revolutionary design of the TORNADO® T2 pump head extends the lifetime and improves the performance of the rotors, the elastomer liners and the mechanical seals. By adopting a modular design approach it reduces the cost of wearing parts extending operating life and significantly reducing the life cycle costs (LCC).

## Drive options

A range of drive options are available to suit specific application and process requirements.

# Optimum choice of material

## YOUR APPLICATION IS THE DECISIVE FACTOR

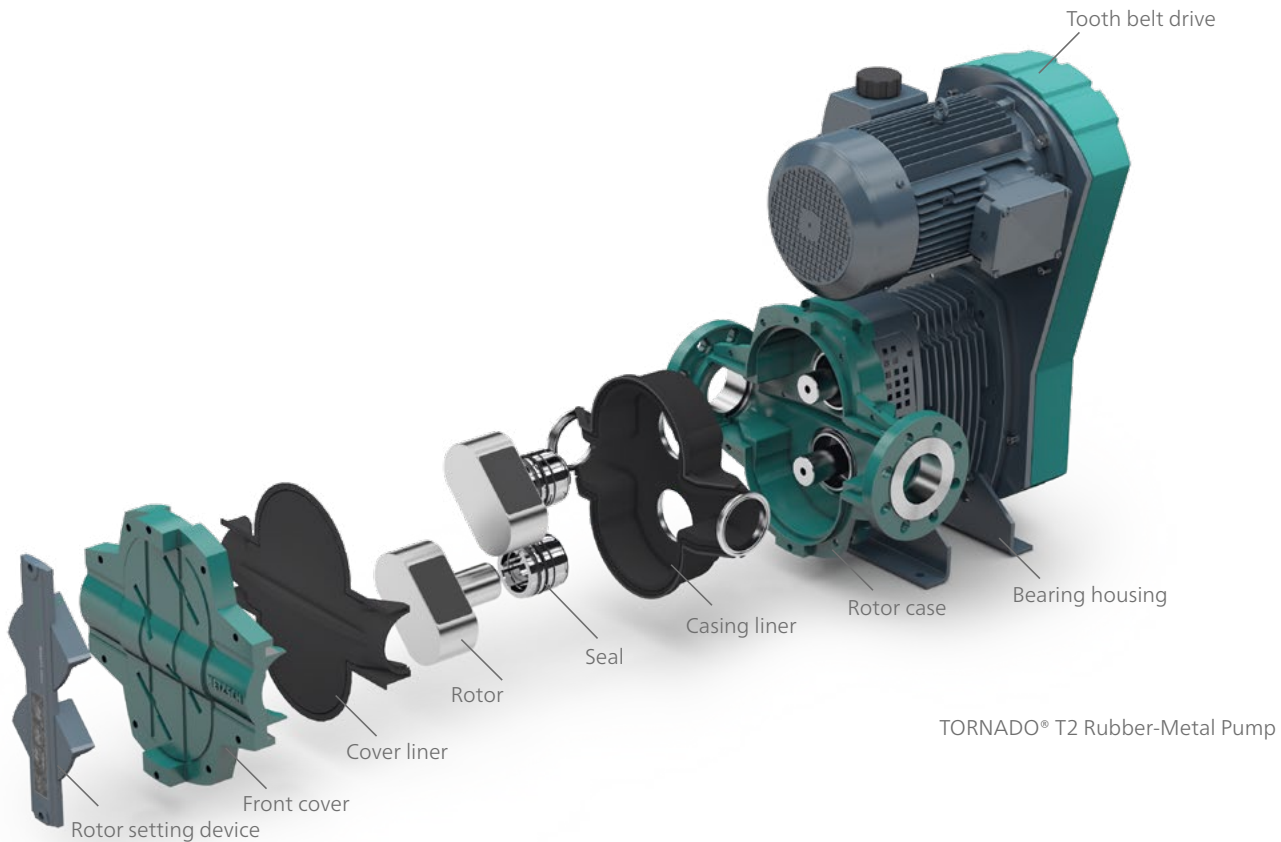

TORNADO® T2 Rubber-Metal Pump

### Stability

**“The best maintenance is no maintenance”**

Plastic deformation and heat generation is reduced by maintaining a uniform elastomeric wall thickness within the pump chamber. Material sections, bearing selection and seal positioning combine to minimize the adverse effects on dimensional changes to pump head geometry due to temperature changes. The design and geometry of the rotors ensures a high level of durability. With the rotor fixing and drive outside of the pump chamber the rotors can have a completely flat continuous front and back face with no dead areas which eliminates the possibility of fibrous

material becoming trapped and compacted. The mechanical seal design and seal face position eliminates dead areas and allows constant circulation of the media around the faces which ensures that the risk of media entrapment and compaction is minimised. The TORNADO® T2 all metal pumps can be manufactured from metals offering higher levels of cleanliness, corrosion or abrasion resistance and can therefore be applied to applications demanding the characteristics of these materials, especially in the low sanitary hygienic or chemical market sectors.

[Click here for the 3D model:](#)



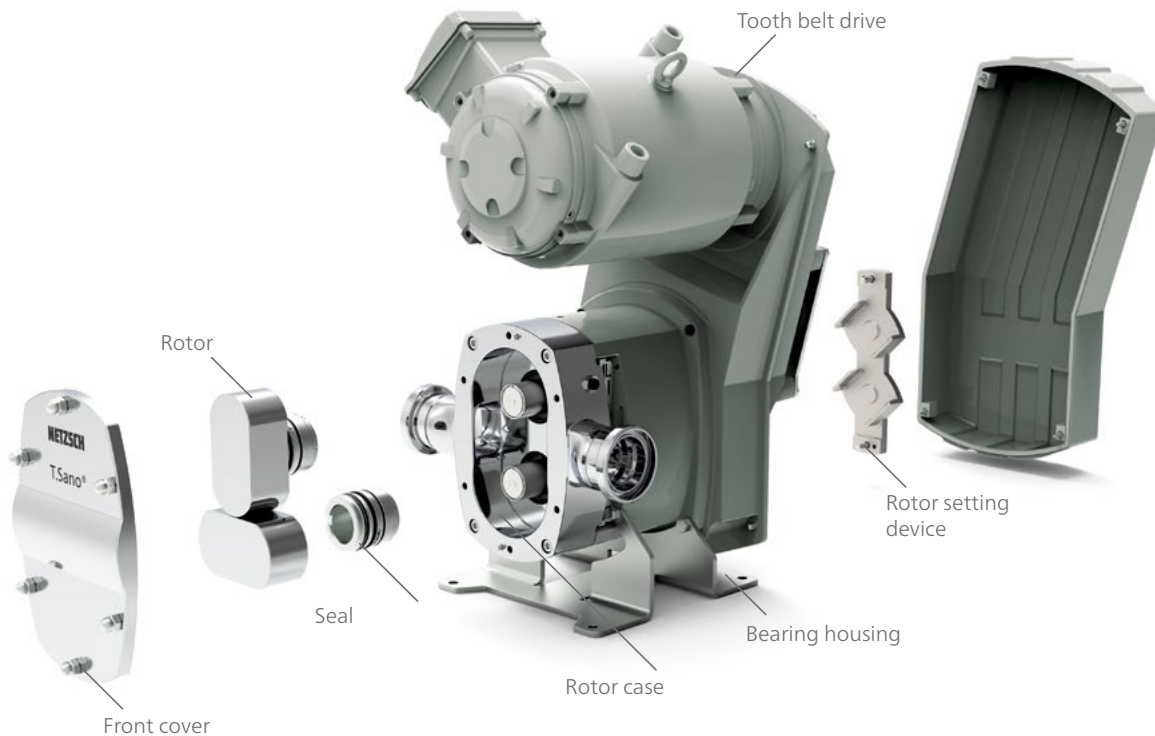

TORNADO® T.Sano® Smooth with completely smooth housing

[Click here for the 3D model:](#)



## Ease of service

### “Full Service In Place instead of Maintenance In Place”

Servicing a rotary lobe pump has never been so easy and all without the need for any special tools. The rotors can be removed and replaced very easily and quickly because they are not bolted or keyed to the shafts within the pump head but fixed with quick-fit non media wetted taper lock assemblies positioned and accessed outside of the pump head. The geometry of the rotors means that they can be fitted and removed independently. There are no keys dictating a unique rotor position which results in faster, easier and cleaner rotor removal and replacement and for rotor

synchronisation a setting device is included as an integral part of the pump front cover. Benefitting from all these features the service time for the TORNADO® T2 has been reduced to significantly less than half the time required for servicing a conventional rotary lobe pump. The pre-set cartridge mechanical seals are fitted directly into the rotor and mounted on the shafts as one assembly. There are various cartridge mechanical seals available all of which fit into a common housing allowing for seal upgrades without modification: “Plug and Play”.

## Process optimisation

### “Maximum reliability through design, material and range of mechanical seals”

The revolutionary NETZSCH PRS (Pulsation Reduction System) guarantees an almost pulsation-free discharge that is of benefit to many process applications. Even when used in conjunction with straight bi-lobe rotors, which ensures better solid handling capability and easier maintenance, the NETZSCH PRS provides an almost pulsation-free flow which outperforms the characteristics of complex multi-lobe helical rotors. The dead space-free design of the pump room prevents product deposits and facilitates cleaning, manually or in the CIP procedures with the all-metal pump, as defined by the EHEDG tests have been proven.

# Surprisingly simple

## THE OIL-FREE SYNCHRONISATION WITH A TOOTH BELT DRIVE



Single tooth belt drive

### Functioning principle

The drive motor transmits power via a double-sided tooth belt which both drives and synchronizes the pump shafts. If required, the drive can be used in conjunction with a frequency converter to achieve a specific flowrate or range of flowrates.

### Operational safe and oil free

**“A new application of tried and tested drive technology”**

An accident causing a complete write-off is inconceivable with this pump. We have replaced the timing gears which have to operate in a managed, maintained environment, with a robust and durable synchronising tooth belt drive. This gives smoothness of operation, load dampening, reduced energy loss and eliminates the need for oil. No more oil filling, draining, changing, leakages, spillage or disposal reduces down time and increases operation time and provides a cleaner, safer working environment. The simple design reduces down-time for service; the result is that the pump is back on stream in less time.

### Environmental awareness

**“TORNADO® T2 – the environment friendly pump”**

By incorporating a tooth belt drive the pump does not use any oil. There is no chance of any environmental pollution due to spillage or leakage. Our customers benefit from low noise levels and reduced heat in the working area around the pump which corresponds with less energy loss.





Versatile combination –  
flexible installation –  
consistent pumping capacity

Both single and double tooth belt drive arrangements are available providing a wide range of speed reduction ratios.



If required a shaft extension for direct in line coupling to electric motor or diesel engine drive is available.

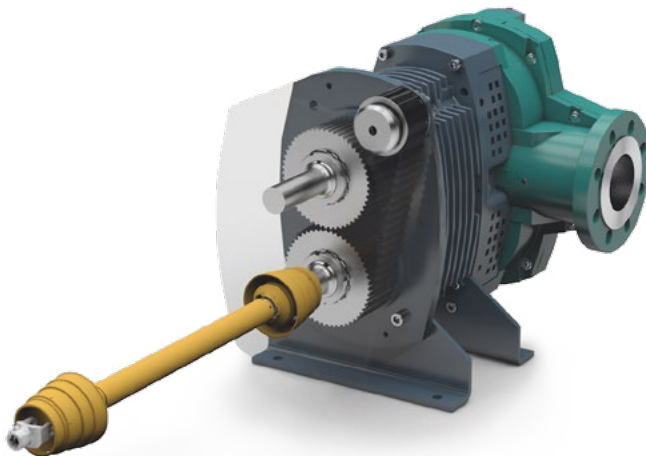

Power take off (PTO) shaft extension for drive from truck or tractor; twin shaft extensions are available where reversible operation is required.

# Optimum operation

## AND PROCESS RELIABILITY AND SAFETY

### From GSS<sup>1</sup> to BSS<sup>2</sup>

- No ingress of the media into the bearing housing in the event of seal failure
- Easy access to seal buffer/quench and barrier/flush connections
- Visual indicator of seal performance

<sup>1</sup> GSS = Gearbox Security System

<sup>2</sup> BSS = Bearing Security System

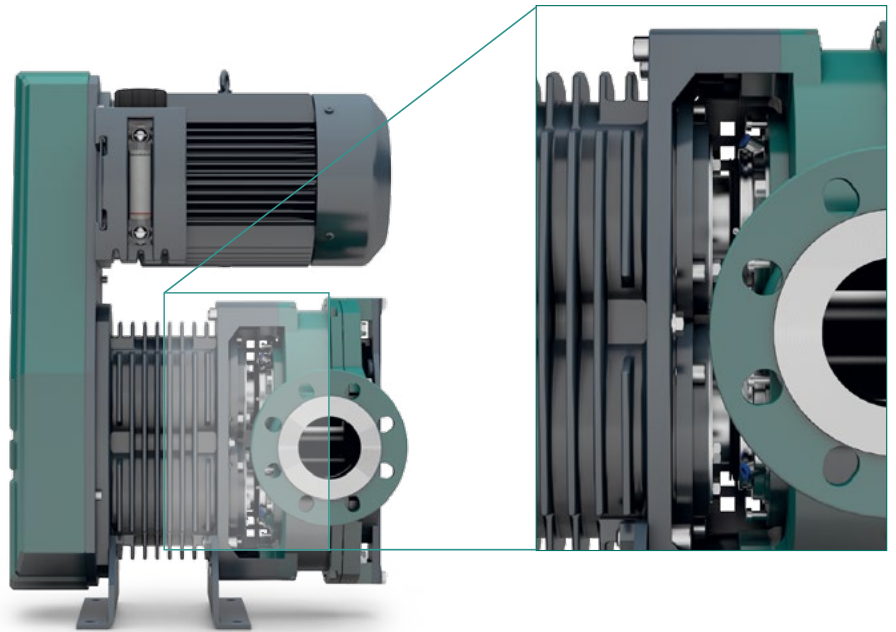

### Design and position of mechanical seal: cartridge unit integral with rotor

- Uninterrupted and direct flow of media to and around seal faces
- Self draining, no dead areas
- No wear of shafts, since seals are designed as robust cartridges
- Easy assembly and disassembly

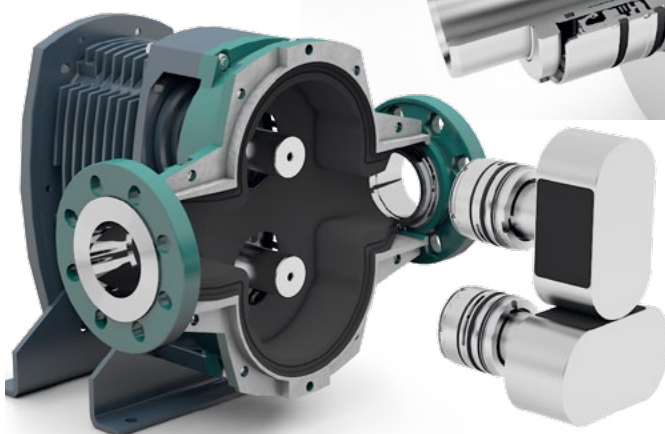

# It's the combination that counts

With the appropriate accessories, which are optionally available for the TORNADO T1 and T2 variants, you increase the operational reliability of your pump and thus help to avoid downtimes of your system.

## Dry running protector

The dry running protection units (STP2A, STP2D) for use with the Tornado rotary lobe pumps operate by monitoring the temperature between rotor and rotor case during normal operation. Should the operating temperature rise over a predetermined set point due to an increase in friction caused by dry running the unit will shut down the pump, thus preven-

ting any damage to the rotor case liner and rotor. The unit controller can be set for two different switch temperatures, for example the first set temperature could be used for the normally pumped media and the second for a different media temperature, for example for a cleaning fluid process.

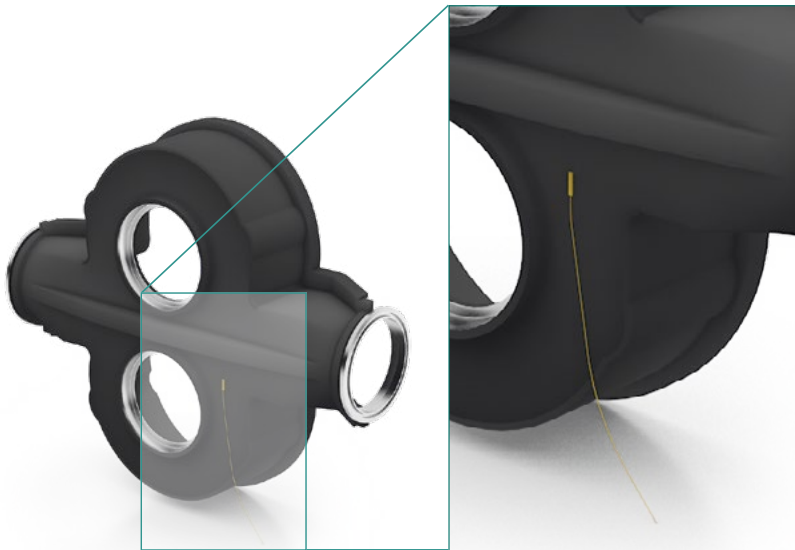

Temperature sensor for dry-running protection

## Quench pot for single mechanical seals

A quench pot is necessary when the shaft seals need to be operated with a quench, but it is not required that the seal is continuously flushed. The provision of a quench pot would be recommended to prevent dry running of the seals or crystallisation of the pumped media.



# It's the combination that counts

## Pressurised flush for double mechanical seals

A double mechanical seal must be used in conjunction with a system providing a pressurised flush or thermo-syphon system. The pressurised flush is required to lubricate the seals, cool the seals and seal area and flush contaminants from the seal chamber. The flush liquid should be compatible with the pumped media, lubricating and have a high specific heat capacity. The pressure of the flush should be 2 bar above the pressure acting on the inboard seal from the pump chamber and flow rate of the flush must also be controlled.

## Frequency converter

For varying speed and flowrates a frequency converter is available.

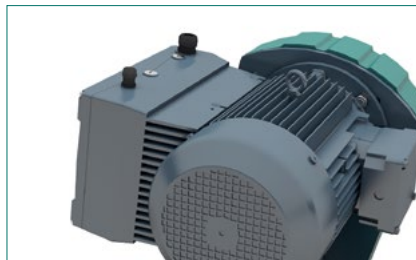

## Over pressure protection

Bypass line with relief valve for over pressure protection.

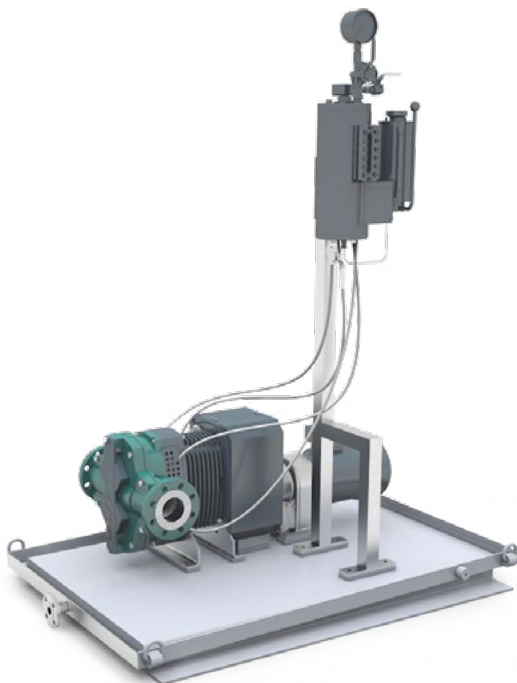
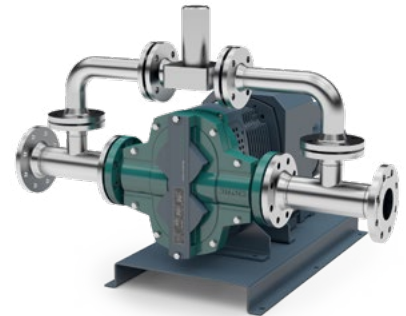

## Mobile Versions

TORNADO® units used with various drives are also used for mobile versions.



## Our product philosophy – your benefit: the best pump for your application

The TORNADO® rotary lobe pump is available in three series with each series offering features and specifications meeting specific market needs.

### Agriculture/Environment

**T.Envi®**  
pressures up to 8 bar

### Industry

**T.Proc®**  
pressures up to 12 bar

### Sanitary/Hygienic

**T.Sano®**  
pressures up to 12 bar

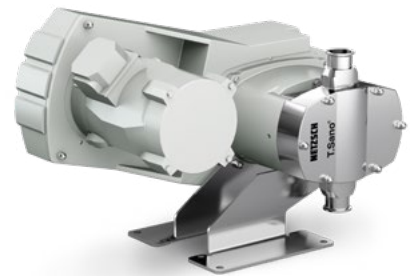

Click here for the  
type and  
performance data:



Click here for the  
type and  
performance data:



Click here for the  
type and  
performance data:



# The conventional TORNADO® T1

## WITH ITS PROVEN QUALITY

The pump performance, size and material of the TORNADO® T1 rotary lobe pumps are matching precisely the properties of the pumped medium and the place of use. Three series with a total of eighteen sizes cover a flow rate range from 1 - 1,000 m<sup>3</sup>/h.

### Pressures of up to 10 bar are standard

The pumps are in the standard version for pressures of up to 10 bar in continuous operation designed. For higher pressures, we offer customised solutions.

### Energy efficiency improved up to 25 %.

Thanks to a new bearing concept, less drive power is required. This reduces energy costs and thus also the TCO.

### Your benefits

- GSS<sup>1</sup> technology for lasting reliability
- Maintenance without removing the pump from the pipeline
- Easy and quick access to the lobes and shaft seal
- Insensitivity to dry running
- Fast availability through stockpiling of the pumps required components
- ATEX and CE certifiable

<sup>1</sup> Gearbox Security System

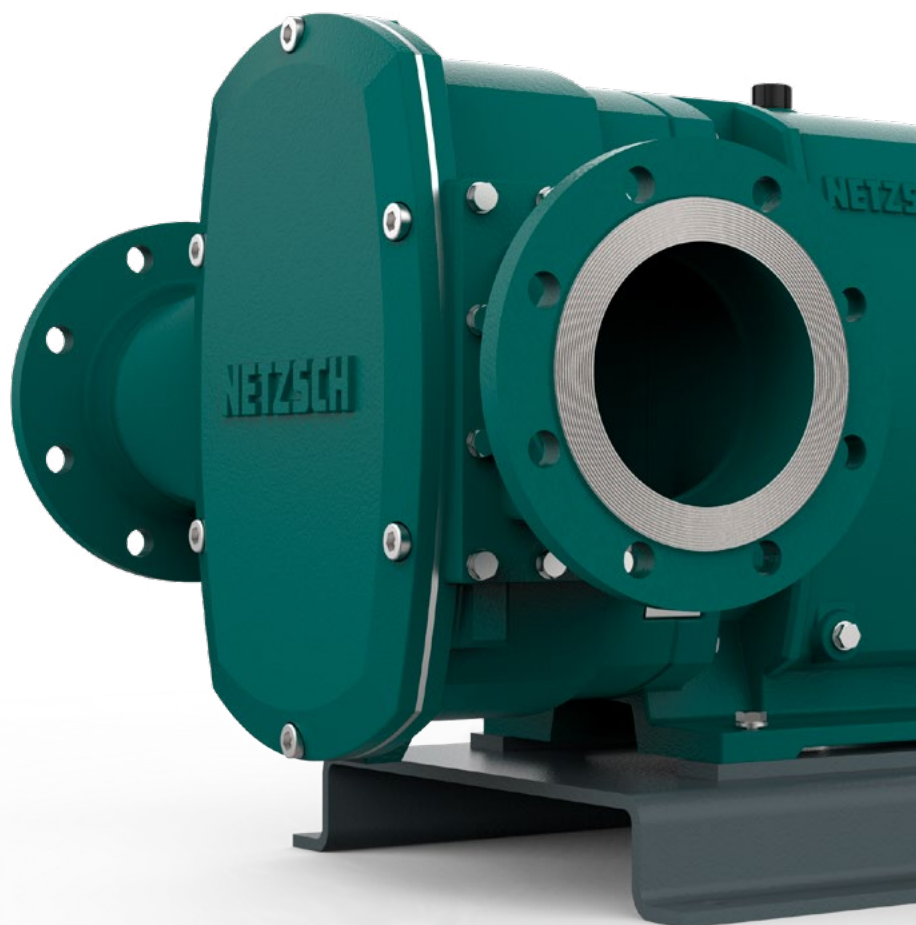

### Reduction of repair times by more than 40 %.

The pump has been designed in such a way that it requires few components. Service work is therefore quick.

### High resistance to wear

Due to the flow-optimised inlet and outlet of the pump chamber, pulsation and vibration have been reduced.

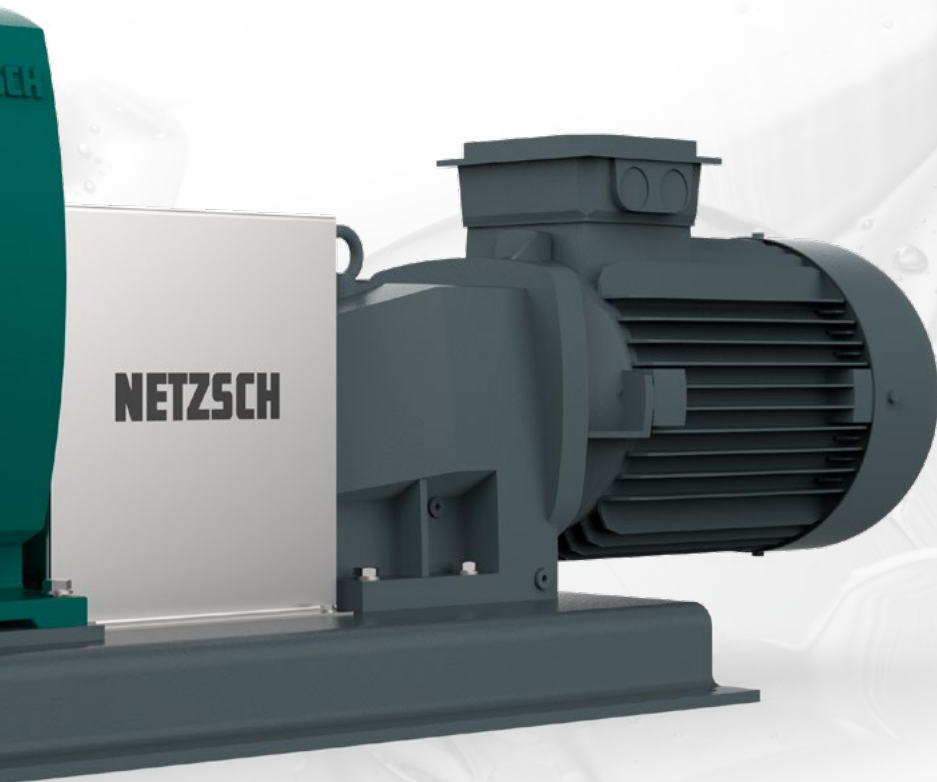

[Click here for the type and performance data:](#)



# The classic TORNADO® T1

## THE DESIGN

Click here for the 3D model:

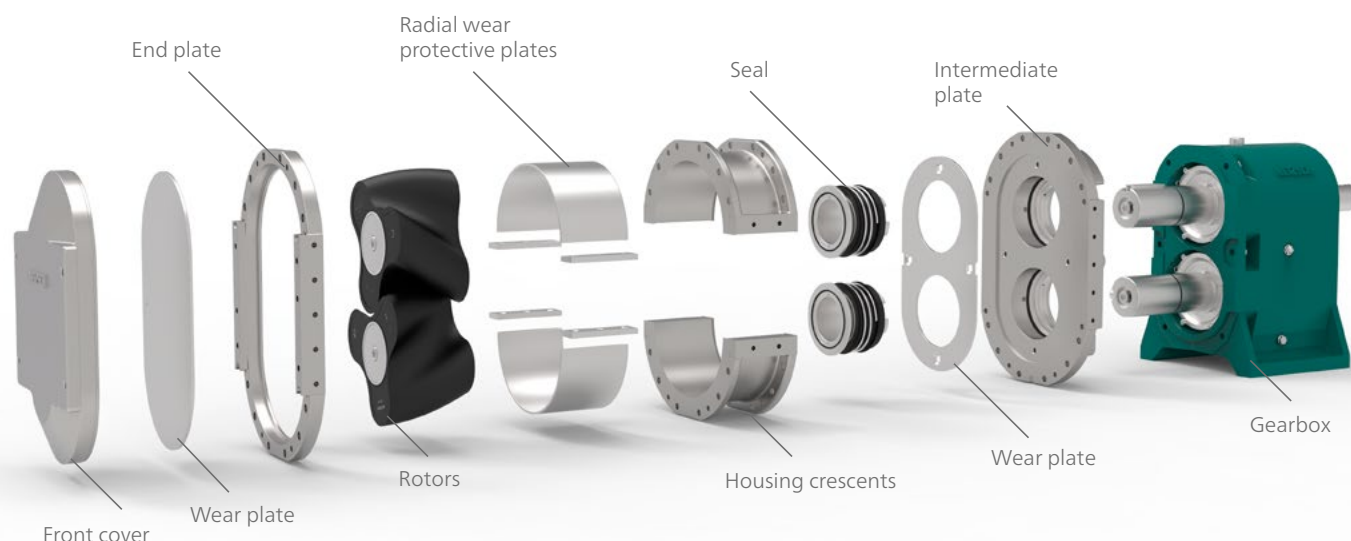

### Front Cover

Rotors, cover seal and product seals can be accessed for inspection, service or replacement by simply removing the front cover. Disassembly of the inlet and outlet pipework and pump housing is not necessary.

### Wear Plates

Abrasion and chemically resistant, replaceable wear plates are fitted both sides of the rotors.

### Rotors

Straight sided or helical rotors are selected to suit individual application requirements. Rotors are available as bi-lobe, tri-lobe or four-lobe and a wide range of materials are available.

### Housing Crescents

Modular construction allows for the crescents to be simply replaced should wear occur. Pump life time can be further extended with the option of replaceable crescent liners.

### Seals

Wide range of product seals and materials are available, which are selected to suit the individual application requirements. Seal arrangements include easy access connections for seal quench or flush.

### Gearbox

The patented gearbox design includes NETZSCH GSS-Technology separating the pump head from the gear box which eliminates cross contamination between the pump media and gear box lubricant.



## Material variance ensures maximum operational reliability:

For particularly demanding applications, NETZSCH also offers the powerful rotary lobe pump in a stainless steel housing.

### Wear protection plates

Especially with abrasive and aggressive pumped media, the service life of the pumps is increased by optionally available radial wear plates. In case of wear, only the protective plates need to be replaced, not the complete housing.

### Stainless steel housing

Corrosion resistance for greater safety and durability in demanding processes.

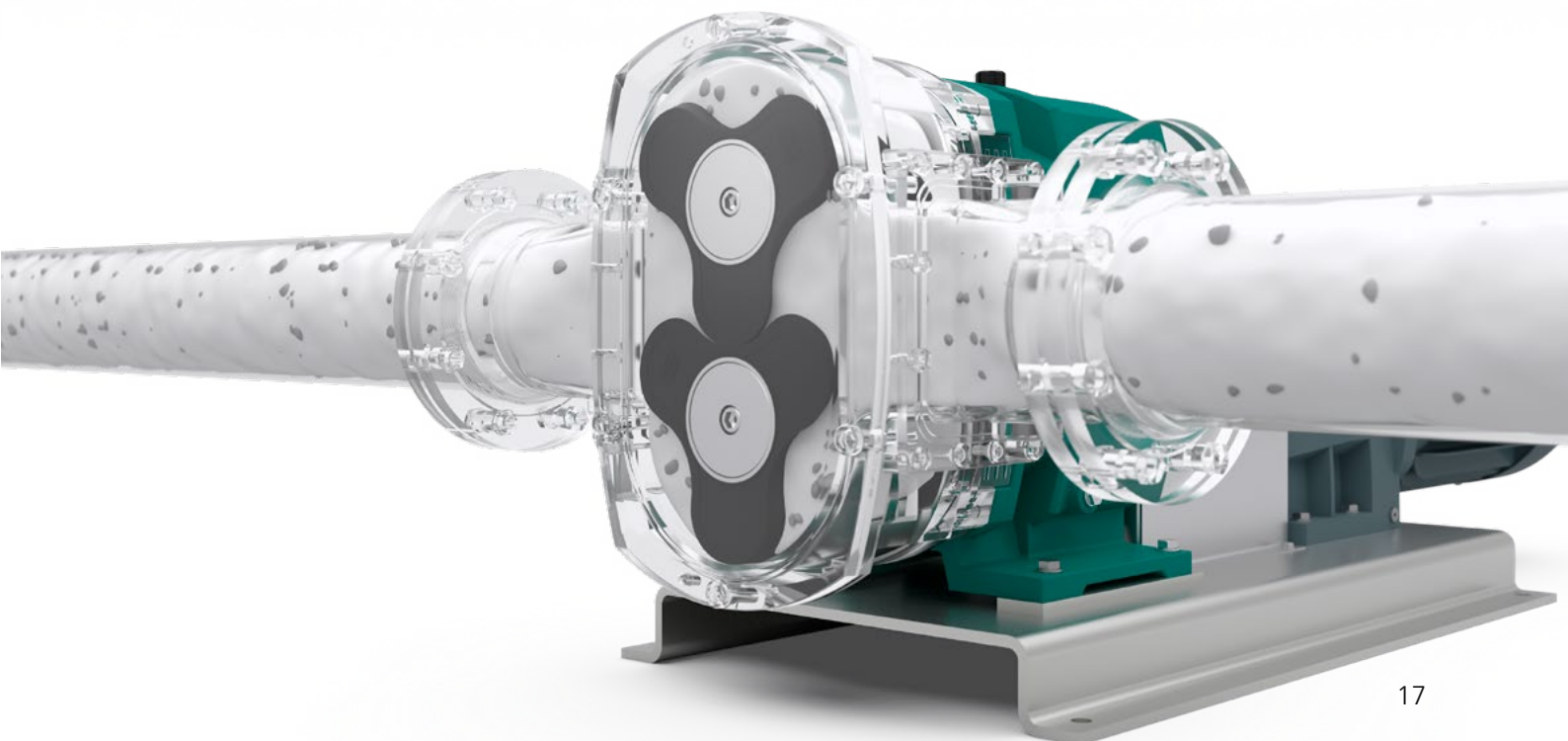

# NETZSCH GSS technology

(GSS = GEARBOX SECURITY SYSTEM)  
– LONG-TERM RELIABILITY

The NETZSCH GSS technology (Synchronous Gear Protection System) guarantees you the highest level of operating safety. The pump chamber and the gearbox are physically separated.

## Your benefits

- Extended operational reliability
- No ingress of the pumped media into the pump gearbox in the event of a product leaking
- No ingress of pump gearbox oil into the pump chamber
- Easy access to the shaft seal flushing connections

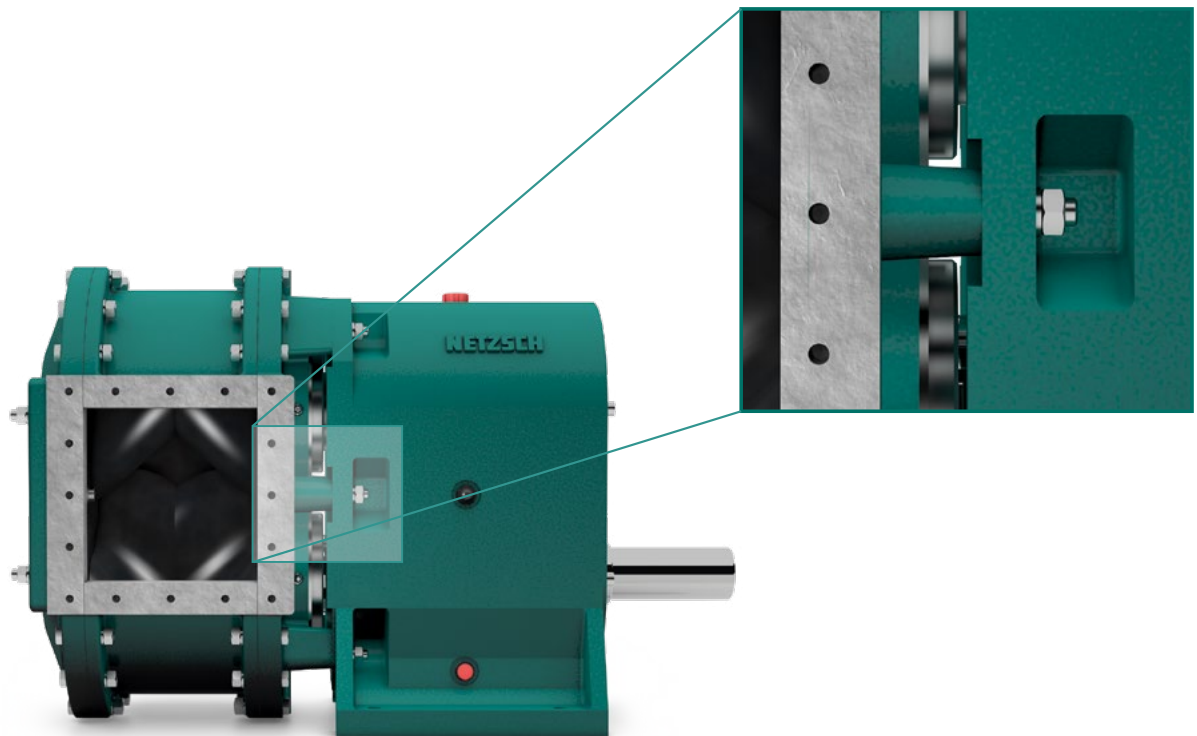

# TORNADO® MOBILE - NOTHING MOVES MORE

The TORNADO® Mobil combines the flexibility and independence of a mobile unit with the robust technology of the rotary lobe pump from NETZSCH. The self-priming, valveless positive displacement pumps are powerful and are optimally adapted to your requirements.

## Performance range and characteristics:

- Constant flow rate, up to 1,000 m<sup>3</sup>/h
- Pressures up to 6 bar, higher pressures on request
- Insensitive to solids, with max. particle size up to 70 mm
- Insensitive to abrasive media
- Self-priming
- Robust
- Simple control

[Click here for the type and performance data:](#)





The NETZSCH Group is an owner-managed, international technology company with headquarters in Germany. The Business Units Analyzing & Testing, Grinding & Dispersing and Pumps & Systems represent customized solutions at the highest level. More than 4.000 employees in 36 countries and a worldwide sales and service network ensure customer proximity and competent service.

Our performance standards are high. We promise our customers Proven Excellence – exceptional performance in everything we do, proven time and again since 1873.

The NETZSCH Business Unit Pumps & Systems offers NEMO® progressing cavity pumps, TORNADO® rotary lobe pumps, NOTOS® multi screw pumps, PERIPRO peristaltic pumps, macerators/grinders, dosing technology and equipment that are custom built for challenging solutions for different applications globally.

## Proven Excellence.

NETZSCH Pumpen & Systeme GmbH  
Geretsrieder Straße 1  
84478 Waldkraiburg  
Germany  
Tel.: +49 8638 63-0  
info.nps@netzsch.com  
www.pumps-systems.netzsch.com

**NETZSCH**®

[www.netzsch.com](http://www.netzsch.com)