

NETZSCH

Proven Excellence.

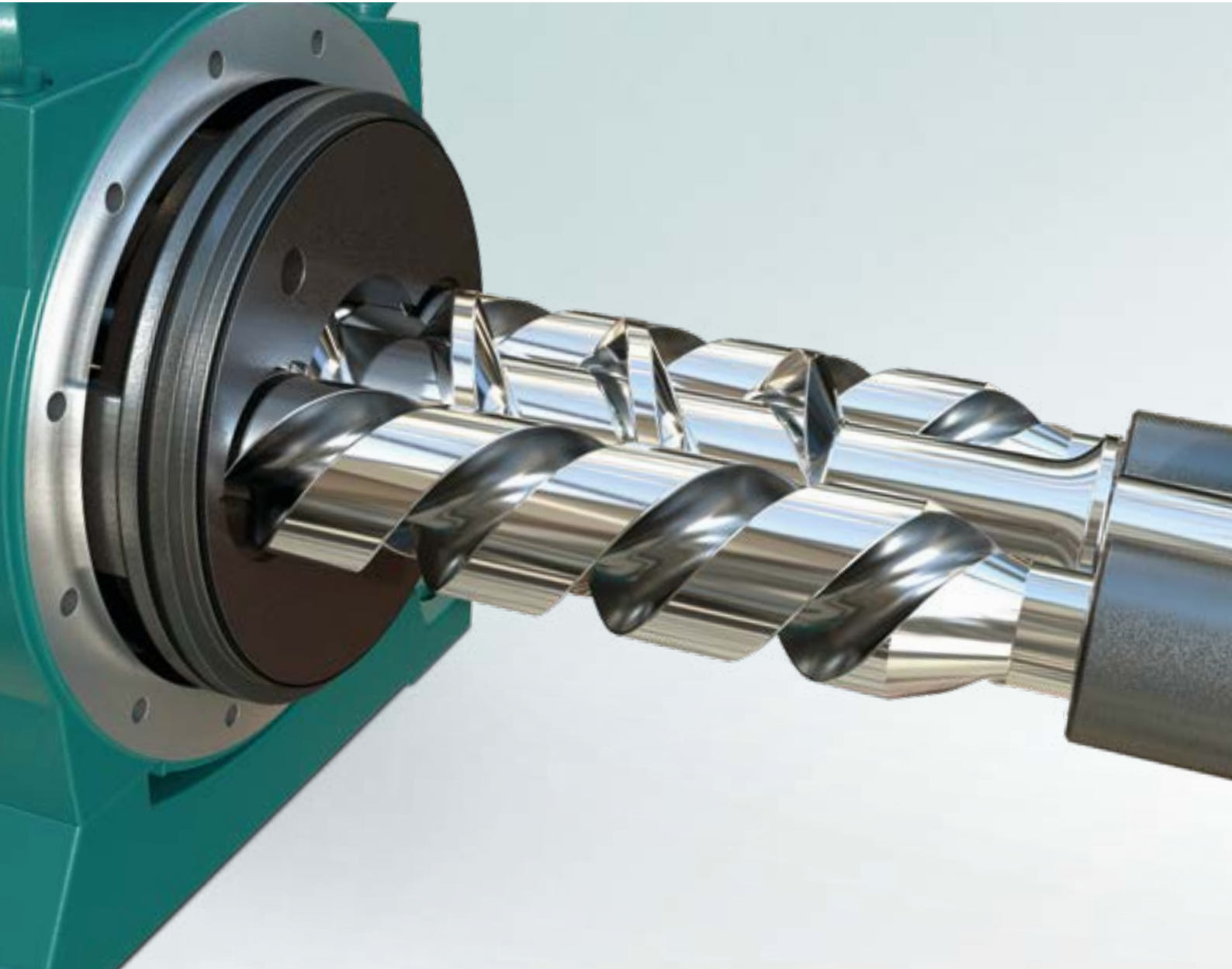

NOTOS[®] Multi Screw Pumps

Reliable and Efficient

Pumps & Systems

NOTOS® MULTI SCREW PUMPS

for all applications

Since 1979 NETZSCH has been manufacturing multi screw pumps to serve a wide range of industries and applications. The most advanced technology is utilized to produce these pumps. Reliability, durability and experience are some reasons why you should choose NETZSCH.

Range of applications

NOTOS® pumps are designed to convey low to well lubricating fluids, low to high viscosity, shear sensitive or chemically aggressive media. They are typically used in the following industries:

- Oil & Gas
- Marine
- Power Generation
- Tank Storage
- Process industries
- Chemical industry
- Food industry
- Cosmetic and pharmaceutical industry

Broad range of materials

Our range of metallic materials extends from grey cast iron and chrome-nickel steel to duplex, super duplex or hastelloy steel. Further metal material options on request.

- No dynamically loaded rubber parts
- Static seals from NBR to FFKM

Capacity and pressure ranges

Multi Screw Pumps are known as pumps for low to high flows and low to high pressures

- Flow rate up to 3,000 m³/h (13,200 gpm)
- Pressure rate up to 160 bar (2300 psi)
- Viscosities up to 500,000 cSt
- Temperature up to 400 °C (750 °F)

“High Efficiency Unique Design”

Due to the “High Efficiency Unique Design” (HEUD), the pumps are optimized in order to increase their performance. Characteristics of this design are:

- Precise tolerances due to the state-of-the-art technology
- Optimized spindle profile
- Patented optimized discharge design

Characteristics

- Self-priming
- Good suction capability
- Continuous flow with low pulsation
- Flow with minimal turbulences
- Gentle product handling
- Low maintenance
- Low lifecycle cost
- Long service life
- Quiet operation
- Several mechanical seal options
- Magnetic drive optional
- Extremely low noise and vibrations
- Vertical or horizontal installation

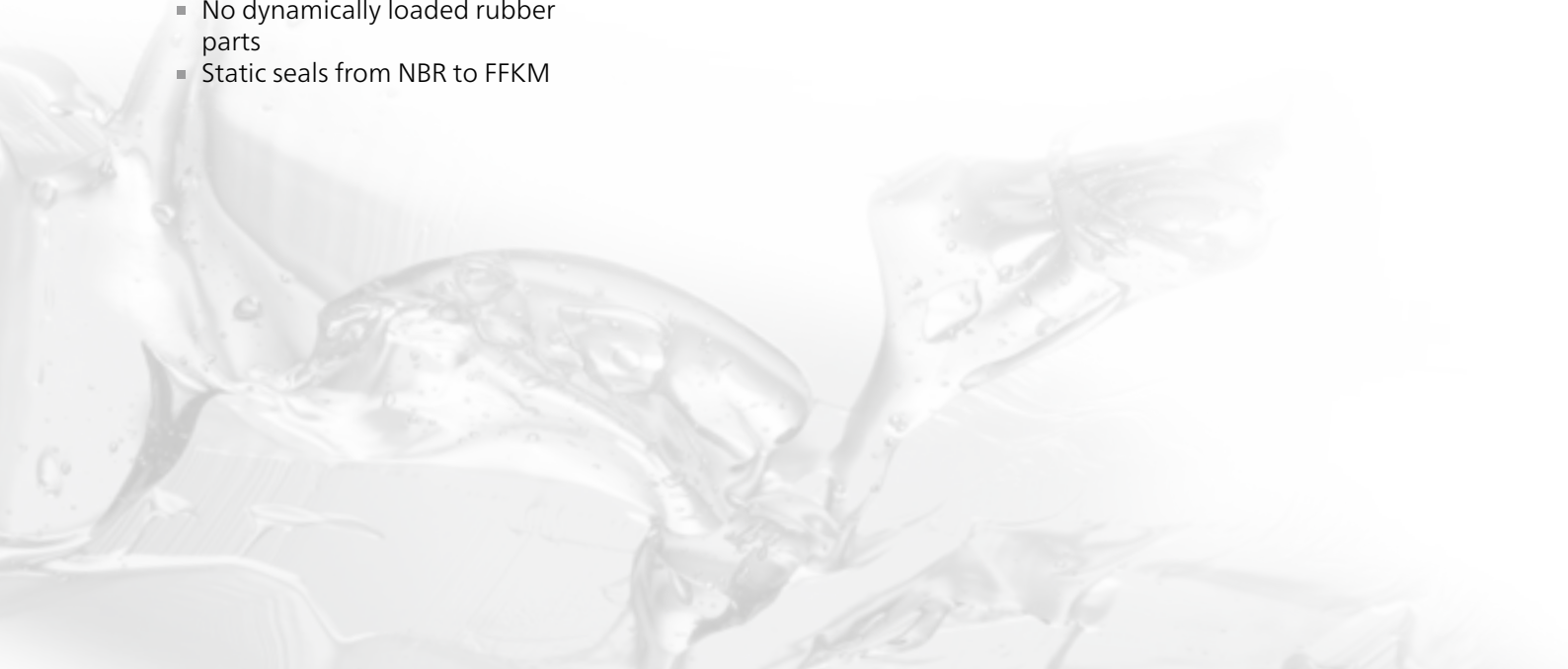

The NOTOS® multi screw pump family comprises of three series in multiple arrangements which serve a wide range of industries and applications. The superior quality standard meets the highest level of requirements from our customers.

Our different pump series to meet your individual demands:



2 NS –
Two Screw Pump

- Flow up to 650 m³/h (2,860 gpm)
- Pressure up to 16 bar (230 psi)
- Temperature up to 300 °C (570 °F)
- Viscosity up to 100,000 cSt



2 NSH –
Hygienic Two Screw Pump

- Flow rate up to 200 m³/h (880 gpm)
- Pressure up to 16 bar (230 psi)
- Temperature up to 140 °C (285 °F)
- Viscosity up to 500,000 cSt



3 NS –
Three Screw Pump

- Flow up to 400 m³/h (1,760 gpm)
- Pressure up to 160 bar (2,300 psi)
- Temperature up to 300 °C (570 °F)
- Viscosity up to 15,000 cSt



4 NS –
Geared Twin Screw Pump

- Flow up to 3,000 m³/h (13,200 gpm)
- Pressure up to 80 bar (1,160 psi)
- Temperature up to 400 °C (750 °F)
- Viscosity up to 200,000 cSt

2NS SERIES

NOTOS® two screw pumps have one drive screw, transferring torque through a hydrodynamic film to the rotating intermeshing driven screw.

Fluid properties:

- From non to light abrasive
- Corrosive and non corrosive
- Low to medium viscosities
- Low to well lubricant fluids

Accessories

- Internal or external relief valve
- Vibration sensors
- Temperature sensors
- API 682 cartridge seals
- Various API seal plans

Arrangements

- Foot, vertical, semi-submersible, housing with replaceable liner or flange mounted
- Heating jacket optional

1 Screws

Nitrated in alloy steel or in stainless steel. The HEUD (High Efficiency Unique Design) provides excellent performance.

3 Bearing Bushes

Internal bearing bushes helps to support radial loads.

2 Housing

Various ports configurations such as top top, side top or in line.

4 Mechanical Seal

Under suction pressure just one mechanical seal is required for the 2NS. Magnetic drive optional.

Advantages

- High efficiency
- Hydraulically balanced
- Quiet operation
- Long service life
- Low pulsation
- Excellent suction capability
- API 676 4th ed., optional

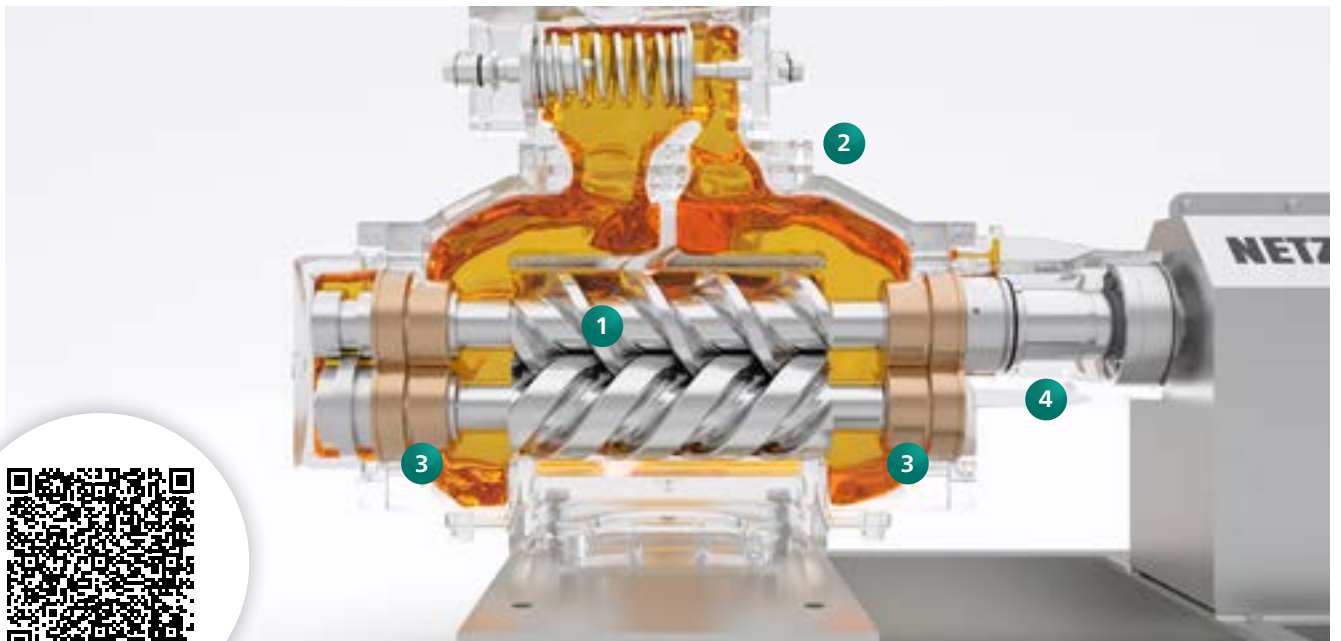

Scan to go directly to the 3D model

3NS SERIES

NOTOS® three screw pumps have one drive screw, transferring torque through a hydrodynamic film to the two rotating intermeshing driven screws.

Fluid properties:

- Non abrasive
- Non corrosive
- Low to medium viscosities
- Lubricant

Accessories

- Internal or external relief valve
- Vibration sensors
- Temperature sensors
- API 682 cartridge seals
- Various API seal plans

Arrangements

- Foot, vertical, semi-submersible
- Housing with replaceable liner, light, top tank version
- Heating jacket optional

1 Screws

Nitrated in alloy steel or in stainless steel. The HEUD (High Efficiency Unique Design) provides excellent performance.

2 Housing

Various ports configurations such as top top, side top, front top or in line.

3 Bearing Bushes

Nitrated bushes help to prevent start up failures and help to support radial loads.

4 Mechanical Seal

Under suction pressure just one mechanical seal is required for the 3NS. Magnetic drive optional.

Advantages

- High efficiency
- Easy maintenance
- Lightweight and small footprint
- Low pulsation
- API 676 4th ed., optional

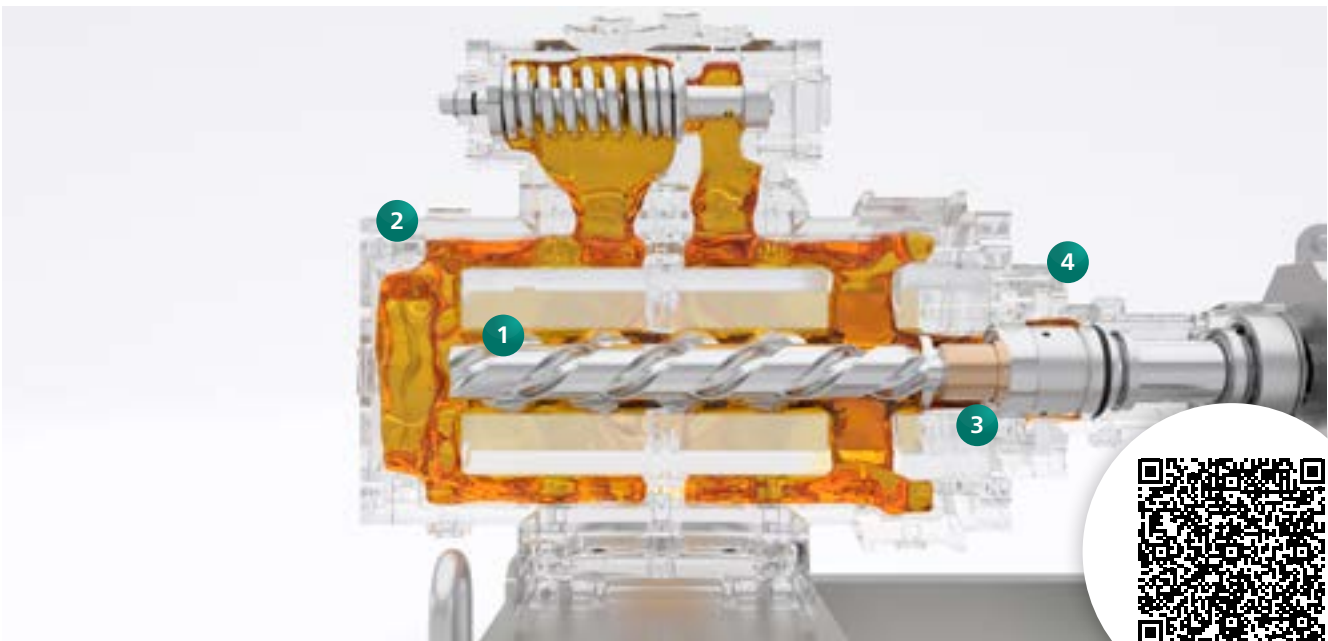

Scan to go directly to the 3D model

4NS SERIES

NOTOS® geared twin screw pumps have two shafts and four screws. The torque is transferred to the driven shaft via helical gears. The design is hydraulically balanced.

Fluid properties

- From non to medium abrasive
- Corrosive and non corrosive
- Low to high viscosities
- Non lubricant and lubricant

Accessories

- Internal or external relief valve
- Vibration sensors
- Temperature sensors
- API 682 cartridge seals
- Various API seal plans

Arrangements

- Housing with replaceable liner
- Heating jacket optional

1 Screws

Nitrated in alloy steel or in stainless steel. The HEUD (High Efficiency Unique Design) provides excellent performance.

3 Timing Gear

Helical timing gears transfer the torque with reduced vibration and noise.

2 Housing

Various ports configurations such as top top, side top or in line.

4 Mechanical Seal

Four mechanical seals under suction pressure.

Advantages

- High Efficiency
- No metal to metal contact
- Small footprint
- Long service life
- Excellent suction capability
- API 676 4th ed., optional

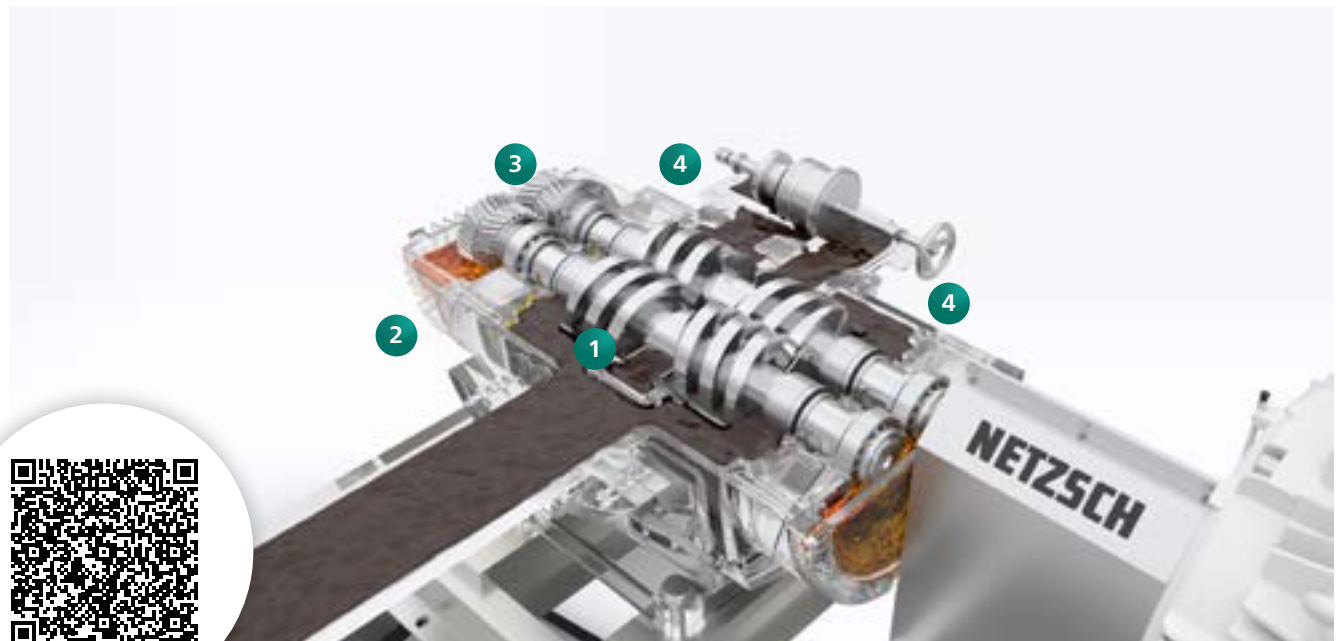

Scan to go directly to the 3D model

NOTOS[®] 2NSH HYGIENIC TWIN SCREW PUMP

Efficiency and high, technological know-how for your process. Designed to optimize the transfer at high working pressures (up to 16 bar or 230 psi) of media with higher viscosity, such as chocolate, fruit yogurt, juices, and pumping them while keeping the integrity and natural properties, without any quality loss. This pump is a practical solution that offers the process greater efficiency and a high technological standard.

Fluid properties

- Low to high viscosity
- With/without solids
- Shear sensitive and shear stable

1 Screws

Stainless steel screws with high efficiency profile, allowing higher flow rates with low fluid shear. Multiple pitch options available, all balanced and with high suction capability. Easy replacement of the screws without disassembly of the bearings. Screws with the same diameter are changeable just by changing the pitch.

2 Housing

Pump housing with a unique design for FSIP[®] – Full Service in Place, allowing the easy and quick pump disassembly, without having to disconnect it from the piping. Available in foot or self-aligned flange design. FDA-approved sealing, without dead spaces.

Accessories

- Base plates
- Various couplings
- Adjustable machine feet
- Flushing supply units for mechanical seals

3 Synchronization gears

Helical gears provide smooth torque transmission between the screws and ensure the contactless operation of the pumping elements.

4 Shaft sealing

Available with single or double seals, both with modular cartridge design and interchangeable from one to another. Connections for flushing or quench are provided.

Arrangements

- The robust and compact conventional design, with optional heating or cooling jacket.
- The FSIP version, with removable screws and the mechanical seal. As a result of this, the servicing downtimes are significantly reduced.
- Both types are available with flange- and foot design.

Advantages

- Versatile use eliminating the need for a CIP pump
- Easy maintenance: simple assembly/disassembly
- Flexibility: the same equipment can be used for pumping fluids with low or high temperature/viscosity
- EHEDG certified

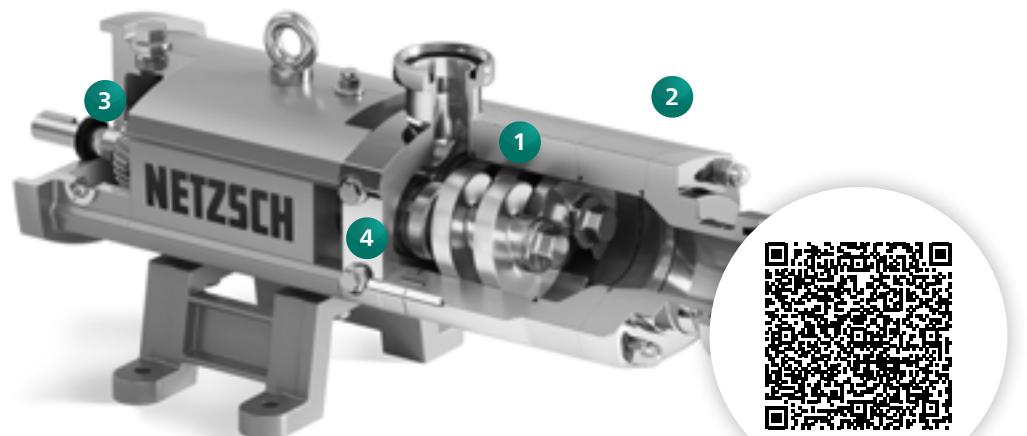

Scan to go directly to the 3D model



The NETZSCH Group is an owner-managed, international technology company with headquarters in Germany. The Business Units Analyzing & Testing, Grinding & Dispersing and Pumps & Systems represent customized solutions at the highest level. More than 4,000 employees in 36 countries and a worldwide sales and service network ensure customer proximity and competent service.

Our performance standards are high. We promise our customers Proven Excellence - exceptional performance in everything we do, proven time and again since 1873.

The NETZSCH Business Unit Pumps & Systems offers NEMO® progressing cavity pumps, TORNADO® rotary lobe pumps, NOTOS® multi screw pumps, PERIPRO peristaltic pumps, macerators/grinders, dosing technology and equipment that are custom built for challenging solutions for different applications globally.

Proven Excellence.■

NETZSCH Pumpen & Systeme GmbH
Geretsrieder Straße 1
84478 Waldkraiburg
Germany
Tel.: +49 8638 63-0
info.nps@netzsch.com
www.pumps-systems.netzsch.com

NETZSCH®

www.netzsch.com