

Tirana
AGRICULTURAL PUMP RANGE

ROBUST

COMPACT

RELIABLE

SURFACE PUMPS

Built on a heavy duty and proven platform, the Tirrana range of helical rotor pumps offers a peace of mind solution to all types of surface water transfer duties.

PERFORMANCE SUMMARY

Capacity upto 360 LPM
Head upto 120 m

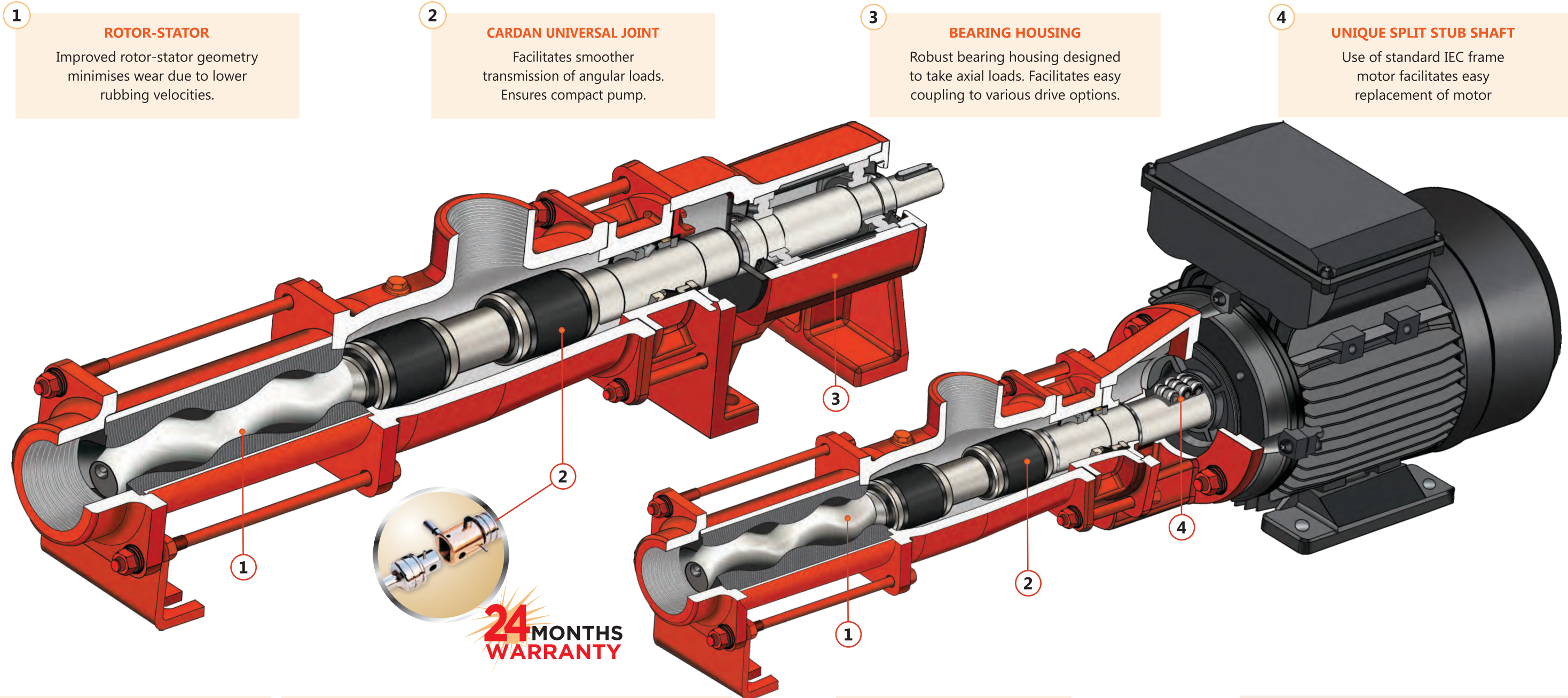

1 ROTOR-STATOR
Improved rotor-stator geometry minimises wear due to lower rubbing velocities.

2 CARDAN UNIVERSAL JOINT
Facilitates smoother transmission of angular loads. Ensures compact pump.

3 BEARING HOUSING
Robust bearing housing designed to take axial loads. Facilitates easy coupling to various drive options.

4 UNIQUE SPLIT STUB SHAFT
Use of standard IEC frame motor facilitates easy replacement of motor

FEATURES

- Low NPSHR, ensure excellent suction lift capability
- Reversible, providing flexibility in operation
- Minimal variation in flow rates with changes in head
- Non Clogging, can handle high percentage of solids in suspension

MATERIAL OPTIONS⁺

Wettable Housing Parts : Cast Iron

Rotor : Stainless Steel - 410, Hard chrome plated

Stator : Natural, Nitrile

Shaft & Coupling Rod : Stainless Steel - 410⁺⁺

⁺Above material options are standard for Tirrana Range, contact Roto for other material requirements.

⁺⁺With Gland Packing, shaft is Hard chrome plated under Gland Area.

APPLICATIONS

- Ideal for **tank filling** or **stock watering** from dams, creeks, wells and rivers.
- Can handle **clean water**, **brown water**, **dirty water** with sand, silt or algae.



PERFORMANCE CURVES

CLOSE COUPLED

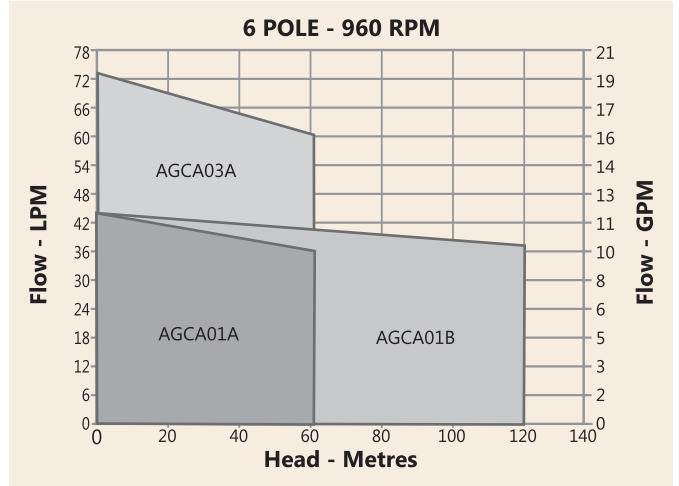
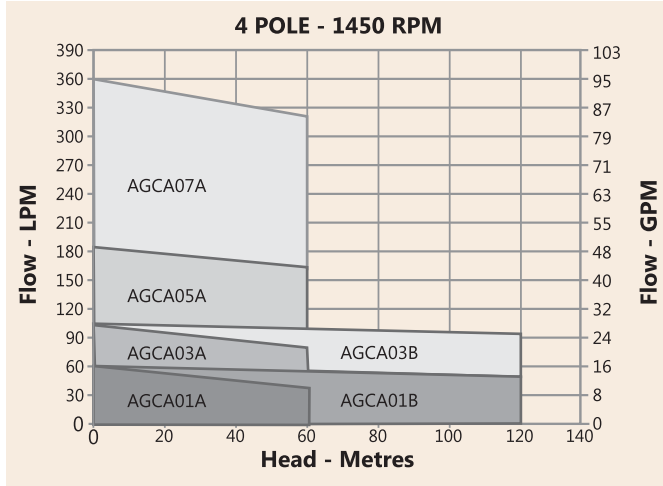

BARE SHAFT

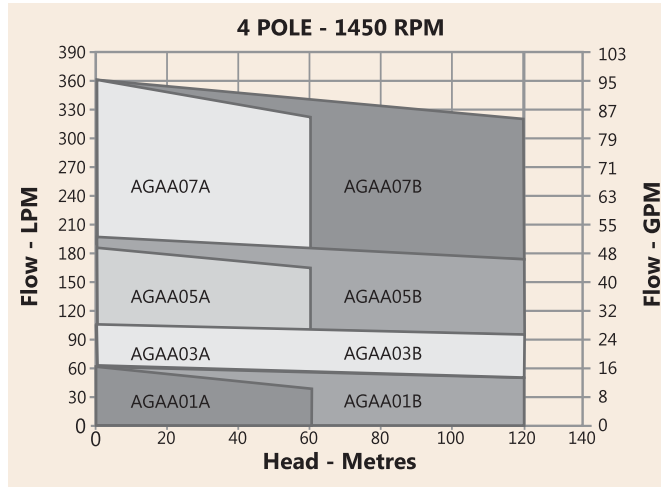

DIMENSIONAL DETAILS

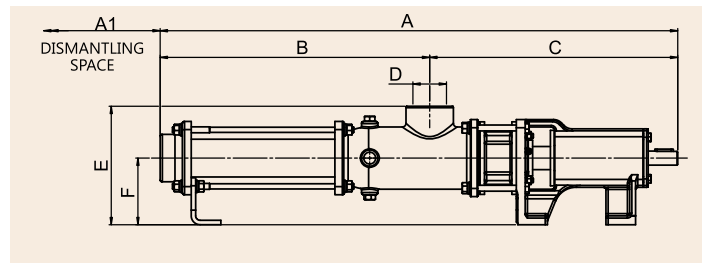
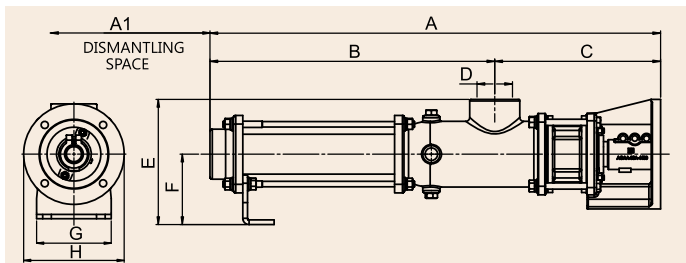

CLOSE COUPLED SERIES

MODEL	A	A1	B	C	D	E	F	G	H	Shaft Dia.
AGCA01A	455	180	266	189	40	135	80	104	120	19
AGCA01B	641	320	429	212	40	160	90	104	140	24
AGCA03A	576	240	364	212	40	160	90	104	140	24
AGCA03B	766	430	544	222	40	170	100	104	160	28
AGCA05A	595	210	344	251	50	180	100	104	160	28
AGCA07A	737	350	486	251	50	192	112	115	160	28

BARESHAFTE SERIES

MODEL	A	A1	B	C	D	E	F	Shaft Dia.
AGAA01A	578	180	266	312	40	135	80	19
AGAA01B	764	320	429	335	40	160	90	19
AGAA03A	699	240	364	335	40	160	90	19
AGAA03B	879	430	544	335	40	160	90	19
AGAA05A	708	210	344	364	50	170	90	19
AGAA05B	868	400	504	364	50	170	90	19
AGAA07A	850	350	486	364	50	170	90	19
AGAA07B	1103	550	684	419	50	197	112	22

All dimensions are in mm

NEW AND IMPROVED DC RANGE

Roto's range of general purpose pumps have been developed for high pressure applications without sacrificing the flow rates.

FEATURES

- Pressure upto 60 m*
- Low shear and linear flow
- Excellent suction lift capabilities
- Can handle liquid with fine solids
- Can handle liquid with varying viscosity
- Flow is directly proportional to the speed
- Minimum impact on efficiencies with varying heads

PERFORMANCE SUMMARY

Capacity	upto 115 LPM
Head	upto 60 m

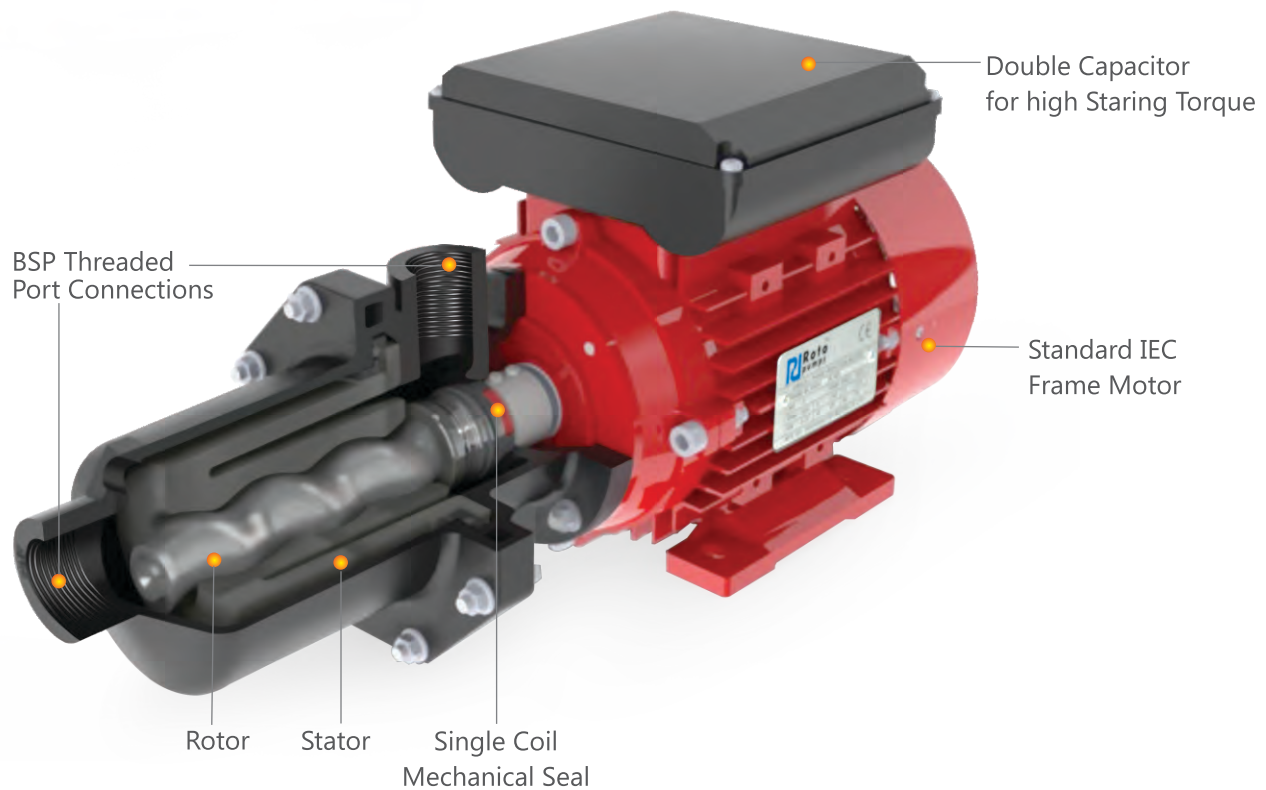

TYPICAL APPLICATIONS

- Feeding ponds and sprinkler systems
- Automatic water pressure systems
- Hosing down of cattle and stock sheds
- Drawing water from wells, creeks or shallow bores
- Drainage of septic tanks
- Feeding to oily water separators
- Transfer and dosing of chemicals and alkalies
- Transfer duties in food processing, winery and vegetable oils
- Brine injection
- Diesel transfer
- Handling surfactants and detergents

*only for selected sizes

MATERIAL OPTIONS

- Ultraviolet resistant acetal co-polymer housing for pump sizes DC 012, 022 & 032
- Cast iron housing parts for pump sizes DC 041 & 051
- Stainless steel hardware
- Stator options
 - Nitrile
 - Natural
 - High Nitrile
 - Fluoroelastomer
 - EPDM
 - Chlorosulphonated Rubber



PERFORMANCE SUMMARY

Pump Size	Capacity (LPM)*	Pressure (m)	Max. Suction Lift (m)	Speed (RPM)	Motor Rating (kW)	Frame Size
DC-012	9.9	60	7.5	1450	0.37	80
DC-022	13.7	60	6.5	1450	0.55	80
DC-032	19.5	40	6.5	1450	0.55	80
DC-041	54.8	30	5.5	1450	0.75	90
DC-051	97.8	30	4.5	1450	1.10	90

*At maximum pressure

DIMENSIONAL DETAILS

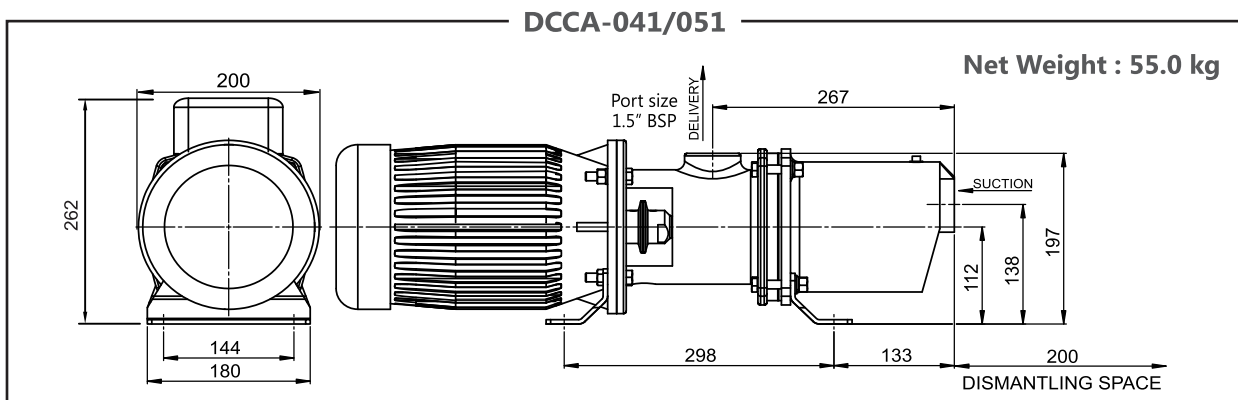
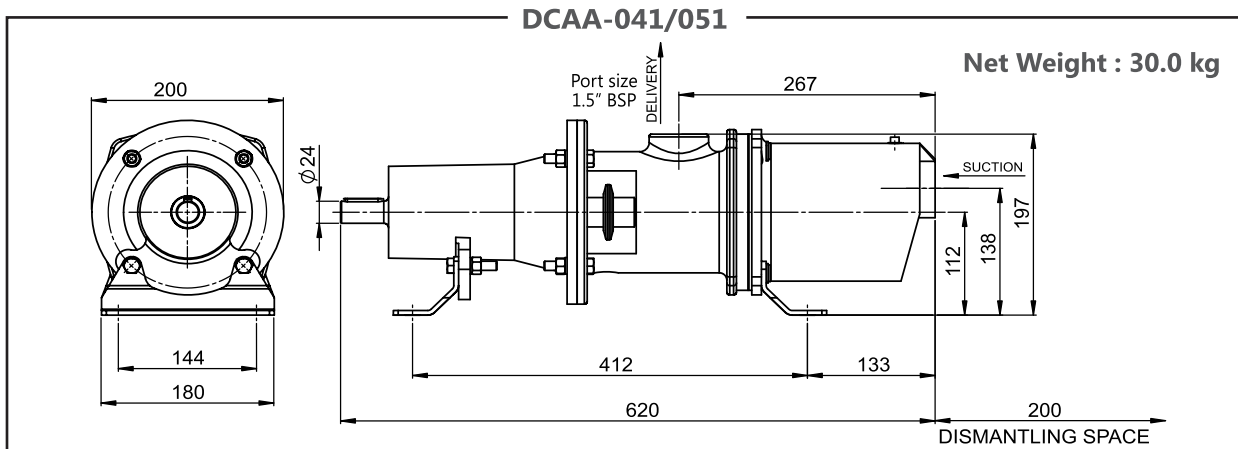
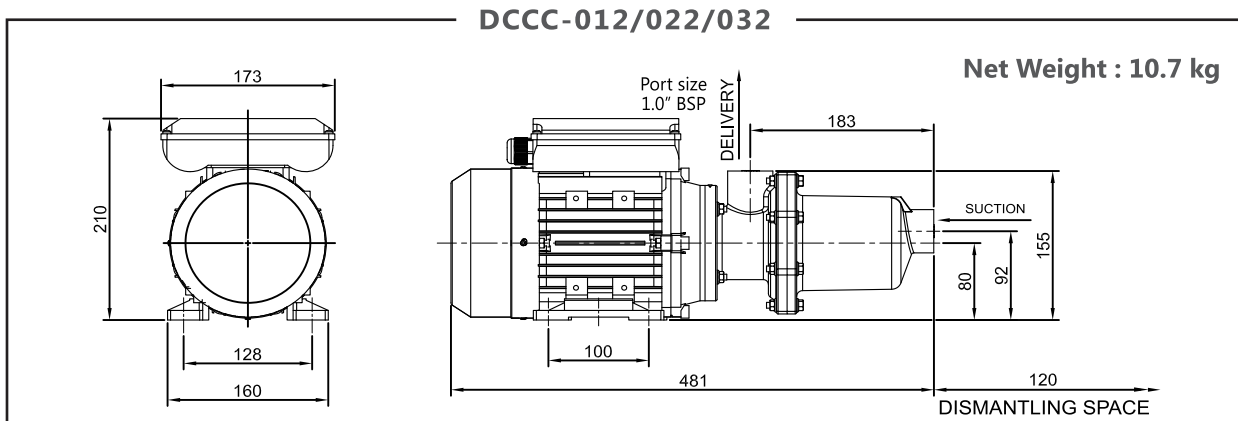
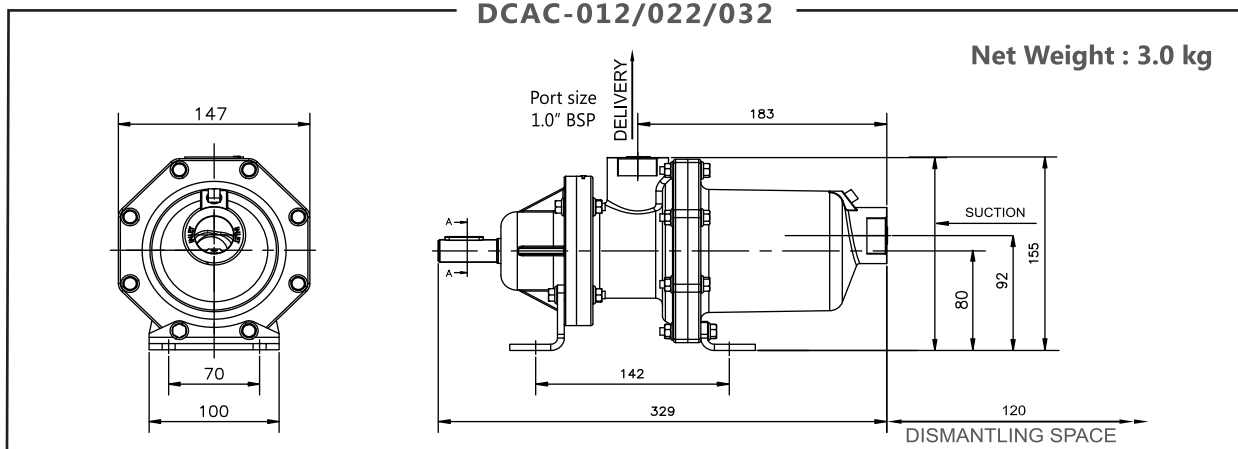

HEAVY DUTY & ROBUST PUMPS

PERFORMANCE SUMMARY

Capacity	upto 2100 LPM
Head	upto 240 m

1 OPTIMISED ROTOR-STATOR GEOMETRY

Improved Rotor-Stator geometry minimises wear due to lower rubbing velocities as compared to conventional geometry, particularly useful in abrasive applications

2 TAPERED ENTRY STATOR

Facilitates easier entry for fluid
Improves suction capability

3 CARDAN UNIVERSAL JOINT

The Cardan type universal joint used in this pump is acknowledged to be far superior to the conventional gear joint or single pin & bush joint which is subjected to extreme concentrated loads, resulting in high wear rates

4 CLOSE COUPLED

Motor lantern is designed to accommodate various construction of drives, reduces the overall length and leads to ease of maintenance

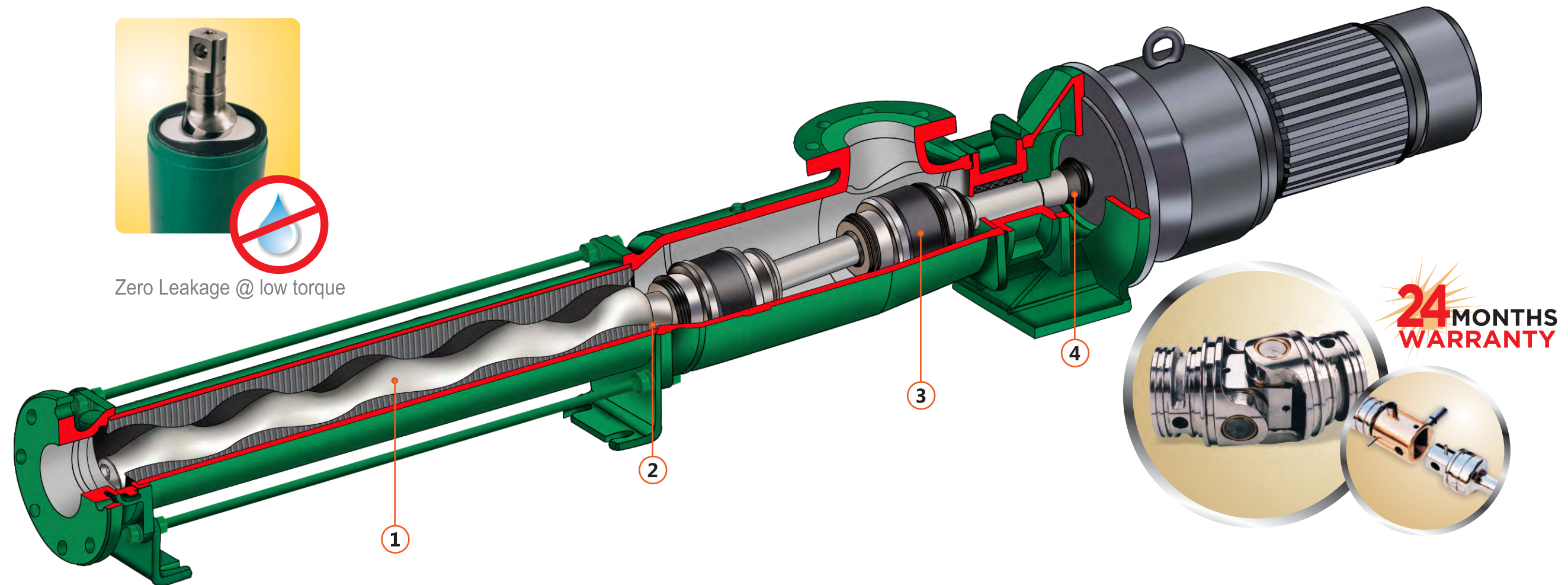

FEATURES

- Low NPSHR ensures excellent suction lift capability
- Non-Clogging can easily handle entrained air or solids
- Lower operating speed ensures less wear and longer life in abrasive applications
- Roto Pumps are self-priming pumps and are shore mounted - eliminating the need for dangerous floating pontoons or walkways
- Uniform steady flow with little to no pulsation
- Flow is proportionate to speed which can help to achieve variable capacities as per application requirement
- Constant flow rates regardless of varying pressures- application rates are kept constant
- Achieves required pressure independent of speed
- Reversible, can be operated in either direction depending on installation - can be used for load out and filling

MATERIAL OPTIONS

Wettable Housing Parts	: Cast Iron, Cast Steel, Cast Stainless Steel, Fabricated Steel and Stainless Steel
Rotor	: Case Hardened Steel, Alloy Steel HCP, Stainless Steel UP/HCP
Stator	: Natural, Nitrile, High Nitrile, EPDM, Chloro Sulphonated Rubber, Fluoroelastomer
Coupling Rod	: Alloy Steel, Stainless Steel
Shaft	: Alloy Steel HCP, Stainless Steel UP/HCP, Shaft Sleeve Optional
Legend	
HCP: Hard Chrome Plated	UP: Unplated

OPTIONAL EXTRAS

- Dry run protection
- Visual and audible alarm
- High & low pressure cut-out
- Motor overload protection

APPLICATIONS

- Dairy effluent pumping
- Green water pumping
- Raw effluent pumping
- Animal effluent pumping
- Dirty water with sand, silt and algae
- Molasses transfer

ANIMAL EFFLUENT

Applications of positive displacement pumps in animal effluent is a key segment of the agricultural market and it is becoming increasingly demanding, Roto pumps offer heavy duty solutions for the transfer and process of dairy shed effluent.

For those applications, pump capacity needs to remain relatively constant over varying discharge pressures, Roto's range of progressive pumps are the ideal choice for such applications.

Significantly low power requirement compared to centrifugal pumps used on dairy effluent systems, reducing power rating from 15kW motor to 5.5kW motor on same applications.

MOLASSES

Molasses and molasses based supplements for stock feed have been used in agricultural market for many years with a wide variety of additives and vitamins carefully blended and added to meet specific recipes. Materials such as grain, crushed peanut shell and a variety of natural oils have been incorporated at various times along with fluid medications.

These products normally have various viscosities, used at different temperatures, have different degrees of abrasiveness and need to be handled carefully so as not to destroy consistency. Roto's range of pumps are the perfect option for such applications.



PERFORMANCE CURVES

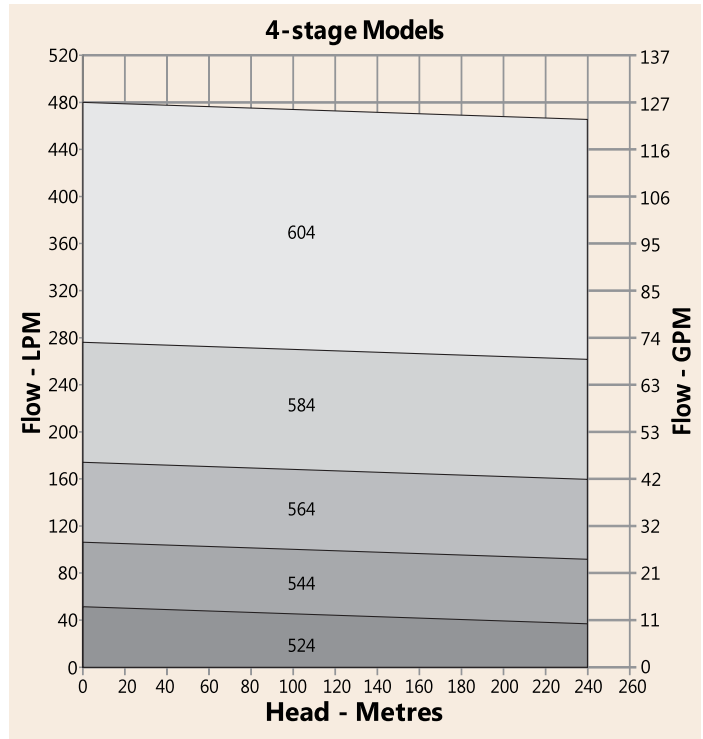
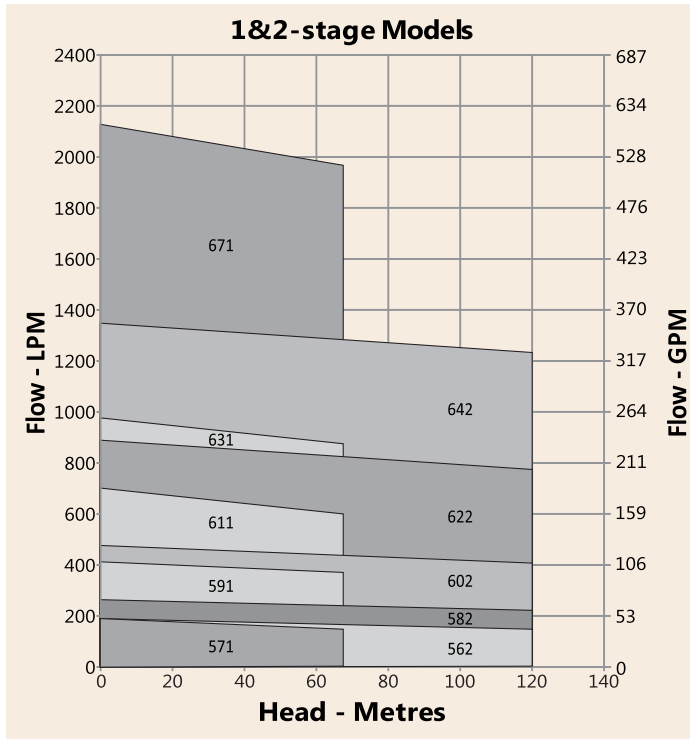

*Higher Capacity and Higher Head available on request

DIMENSIONAL DETAILS

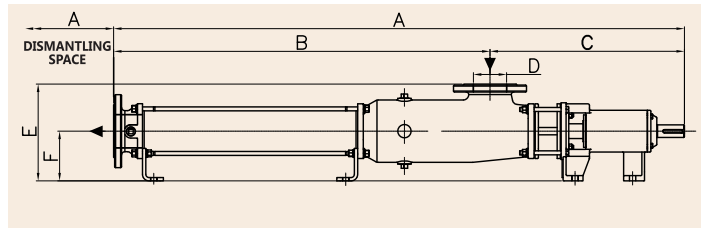
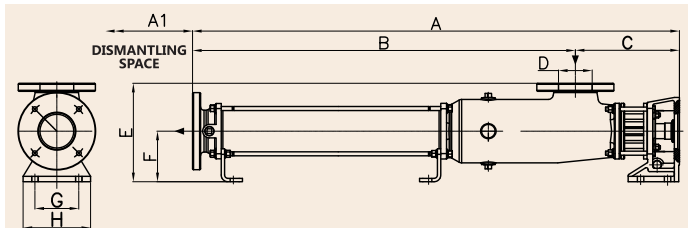

CLOSE COUPLED SERIES									
MODEL	A	A1	B	C	D	E	F	G	H
RLCB571	897	450	649	248	65	212	112	85	115
RLCB591	1147	720	902	245	80	262	130	83	120
RLCB611	1477	750	1202	275	100	272	130	83	120
RLCB631	1530	850	1255	275	100	272	130	83	120
RLCB671	1880	950	1521	359	125	330	150	100	150
RMCB562	1189	600	939	250	65	255	130	83	120
RMCB582	1444	670	1135	309	100	292	150	100	150
RMCB602	1570	810	1261	309	100	292	150	100	150
RMCB622	1978	1000	1595	383	125	370	190	130	200
RMCB642	2132	1160	1749	383	125	370	190	130	200
RMCB524	1277	670	1027	250	65	255	130	83	120
RMCB544	1781	1000	1472	309	100	292	150	100	150
RMCB564	1954	1200	1645	309	100	292	150	100	150
RMCB584	2118	1350	1809	309	100	292	150	100	150
RMCB604	2483	1625	2138	345	100	365	190	130	200

BARE SHAFT SERIES									
MODEL	A	A1	B	C	D	E	F	Shaft Dia.	
RLAB571	1068	450	649	419	65	212	112	22	
RLAB591	1319	720	902	417	80	262	130	24	
RLAB611	1680	750	1202	478	100	272	130	28	
RLAB631	1733	850	1255	478	100	272	130	28	
RLAB671	2158	950	1521	637	125	330	150	38	
RMAB562	1392	600	939	453	65	255	130	28	
RMAB582	1721	670	1135	586	100	292	150	38	
RMAB602	1847	810	1261	586	100	292	150	38	
RMAB622	2291	1000	1595	696	125	370	190	48	
RMAB642	2445	1160	1749	696	125	370	190	48	
RMAB524	1480	670	1027	453	65	255	130	48	
RMAB544	2058	1000	1472	586	100	292	150	28	
RMAB564	2231	1200	1645	586	100	292	150	38	
RMAB584	2395	1350	1809	586	100	292	150	38	
RMAB604	2898	1625	2202	696	100	370	190	38	

Note:- Lantern variety and Shaft dimensions of close coupled models are available on request.

All dimensions are in mm

Roto Pumps Limited, Manufacturing Plant, India



Melbourne Office & Warehouse



Manchester Office & Warehouse



Roto Pumps North America, Inc



... moving fluids positively

ROTO PUMPS LTD.

Marketing Head Office

Roto House,13, Noida Special Economic Zone, Noida - 201305, INDIA
Tel.: +91 120 2567902-5 Fax: +91 120 2567911
Email: contact@rotopumps.com

Branch Offices and Warehouses

United Kingdom

Unit 1 St Elizabeths Park, Grey Street, Denton, Manchester, M34 3RU
Tel.: +44 161 4775511 Fax: +44 161 4747900
Email: sales@rotopumps.co.uk

Australia

26, Deans Court, Dandenong South, Victoria 3175
Tel.: +61 3 97945200 Fax: +61 3 97945900
E mail: melb@rotopumps.com.au

www.rotopumps.com

Subsidiaries

Roto Pumpen GmbH

Am Brühl 17, 32423 Minden, Germany
Tel: +49 571 40410077,
Email: sales@rotopumpen.de

Roto Pumps North America, Inc.

5889 S Garnett Rd. Tulsa ,Oklahoma 74146
Tel: +1 918 280 9144,Fax: +1 918 806 6853
Email: info@rotopumpsna.com

Roto Pumps Africa (Pvt) Ltd

3, Sun Rock Close Germiston 1401, Africa
Tel.: +27 10 100 3774
Email: sales@rotopumps.co.za