



AMERICAN-MARSH PUMPS

“DURABILITY BY DESIGN SINCE 1873”

320 Series Vertical Sump Pumps

**Flows to: 9,200 GPM
Heads to: 985 Feet
Temperatures to: 400°+ F**

140 Years of Pump Manufacturing

American-Marsh Pumps, one of the oldest pump lines in America, are pump products steeped in heritage. Since 1873, the American-Marsh line of pumps has withstood the test of time. During the last 140 years, over 100 varieties of pumps have been designed and built. From steam pumps to centrifugal pumps, American-Marsh pumps have been built to meet the ever changing requirements of society. Over the last century through continuous product development, more American-Marsh models have been retired than most other pump manufacturers have ever produced. Hundreds of thousands of pumps have been made, all designed for longevity, allowing many of them to continue servicing customers over 50 years.

All of our pumps have three superior characteristics; Design, Performance, and Durability. Our engineering department, which includes an in-house pattern shop, designs each pump so that installation and maintenance is easy. Our performances are engineered to meet or beat the competition in each category. For 140 years, American-Marsh Pumps products have

provided cost effective solutions by building pumps to last. Durability by design is always the most cost effective solution. From engineering and design to final assembly, experienced people control each step of the manufacturing process with quality control inspections performed at each step. All pumps shafts are heat straightened. All impellers are computer balanced. Pump testing is done in our new state of the art test facility. All of these factors ensure you receive consistent quality product every time.

American-Marsh Pumps has provided quality pump products for over 140 years. At American-Marsh Pumps, we know that long life and superior performance are the keys to satisfied customers. By understanding your needs, we can design products that meet those needs. Our product family reflects years of customer input, product upgrades, redesign and new product development, all focused on meeting and exceeding your expectations.

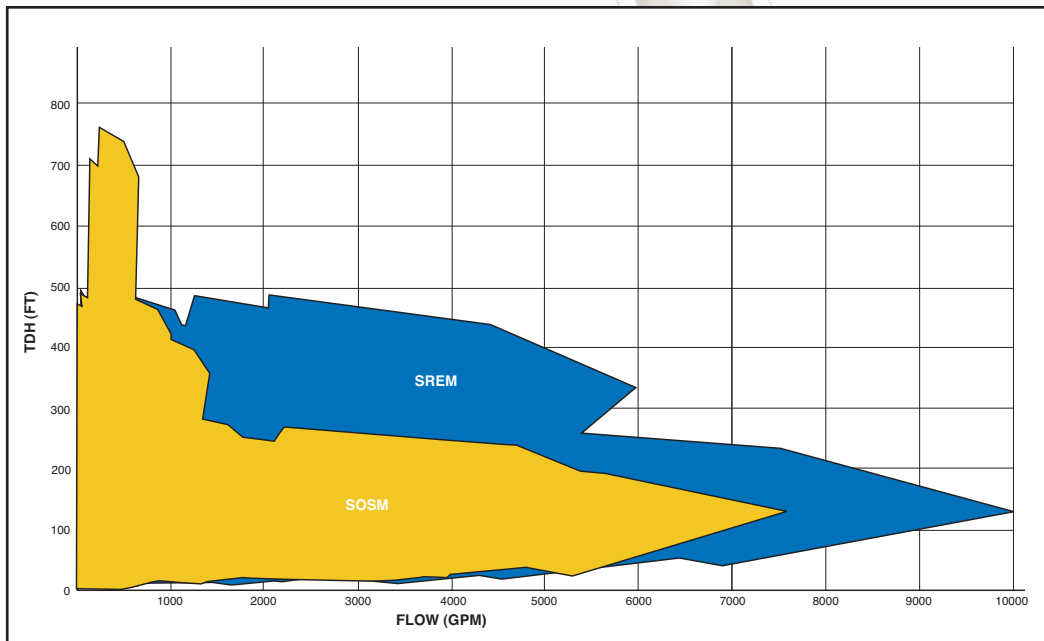



AMERICAN-MARSH PUMPS

Specifications

Models SREM & SOSM

Casing: The SREM casing is constructed of high tensile cast iron or other specified material. It is of the volute type, carefully and accurately proportioned to permit smooth flow and to convert high velocity energy of the fluid as it leaves the impeller into pressure. Suction and discharge nozzles are casted integral with the volute and are of 250 psi dimensions. All SREM models feature a 250 psi case working pressure. The casing has cast integral feet standard and the discharge port is of the vertical centerline type. Necessary vent and drain openings are provided. The SOSM casing is constructed of high tensile cast steel or other specified material. It is of the volute type, carefully and accurately proportioned to permit smooth flow and to convert high velocity energy of the fluid as it leaves the impeller into pressure. Suction and discharge nozzles are flanged and are cast integral with the volute. The casing has cast integral feet standard and the discharge port is of the vertical centerline type. The casing assembly fully meets ANSI B73.1 dimensional and performance requirements. Necessary vent and drain openings can be provided upon request.

Impellers: The SREM impeller is of the end suction type, casted in one piece of 304 stainless steel or other specified material. All impellers are hydraulically and dynamically balanced prior to assembly and all impellers have pump out vanes or a rear case wear ring standard on the back side of the impeller to reduce material from building up near the inboard bearing. The SOSM impeller is of the reverse vane, end suction type, casted in one piece of cast steel or other specified material. Running clearances need to only be adjusted between the back of the impeller and the casing adapter. This design allows for repeatable factory tolerances. All impellers are hydraulically and dynamically balanced prior to assembly. Front semi-open impellers can be supplied upon request. All models meets the stringent performance requirements of ANSI B73.1. American-Marsh Pumps also offers 4 Low-Flow models to meet difficult low-flow/high-head process applications.

Casing Wear Rings: Standard SREM enclosed impellers are designed with integral case wear rings accurately turned to provide close running fits in the casing. The diameters of these rings are such as to reduce end thrust to a minimum. On larger models a rear case wear ring is provided for additional wear resistance.

Inboard Head: The SREM inboard head is constructed of cast iron or other specified material. The SOSM inboard head is constructed of cast steel or other specified material. The inboard head connects the fluid end to the support pipe and contains the inboard head bearing.

Shaft: The shaft is of 416 stainless steel, polished and of large diameter to prevent vibration. Lineshaft bearings are spaced to minimize shaft deflection. The shaft is supported by the thrust bearing housing, located at the surface plate, which has integral lateral adjustment.

Support & Discharge Pipe: The support pipe is of black iron, one end flanged to the inboard head and the other end flanged to the sump cover. Intermediate bearings will be flanged between multiple pieces of support column and spaced accordingly. The discharge pipe is flanged, one end connected to the discharge elbow and the other to the system piping. This pipe connection terminates three inches above the sump cover plate.

Discharge Elbow: The discharge elbow is of high tensile cast iron or of other specified material and of the long radius type flanged to the discharge of the casing and to the discharge pipe assembly.

Sump Cover: The sump cover is of carbon steel, teardrop or of other shape as desired. The sump cover supports the entire weight of the complete pump assembly. Optional simplex and duplex sole plates are available with a four inch vent and a manhole cover designed to give access to the pumping assemblies.

Model SREM Vertical Sump

- Sizes:** 1-1/2" to 12" Discharge
- Flows:** 9000 GPM
- Heads:** 450 Feet TDH
- Temp:** 250° F
- Pit Depths:** 25' Settings



Enclosed Impeller

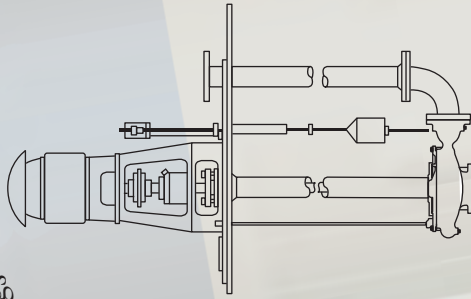

Services:

- Aerospace
- Building Trades
- Chemical
- Construction
- Food & Beverage
- General Industry
- Marine
- Mining & Aggregate
- OEM
- Oil & Gas
- Power Generation
- Petro-Chemical
- Pharmaceutical
- Pulp & Paper
- Semiconductor
- Water & Wastewater

Teardrop Baseplate

- Eliminates removing entire coverplate for servicing pump
- Motor pedestal, thrust bearing housing, discharge pipe, optional float switch and optional stuffing box all mount to baseplate

Motor

- Stocked C-face for quick delivery

Thrust Bearing Housing

- Integral thrust bearing housing featuring simplex bearing or optional duplex bearing
- Optional stuffing box

Float Rod Stuffing Box (optional)

- Used for gas tight applications
- Constructed of bronze or other specified alloy

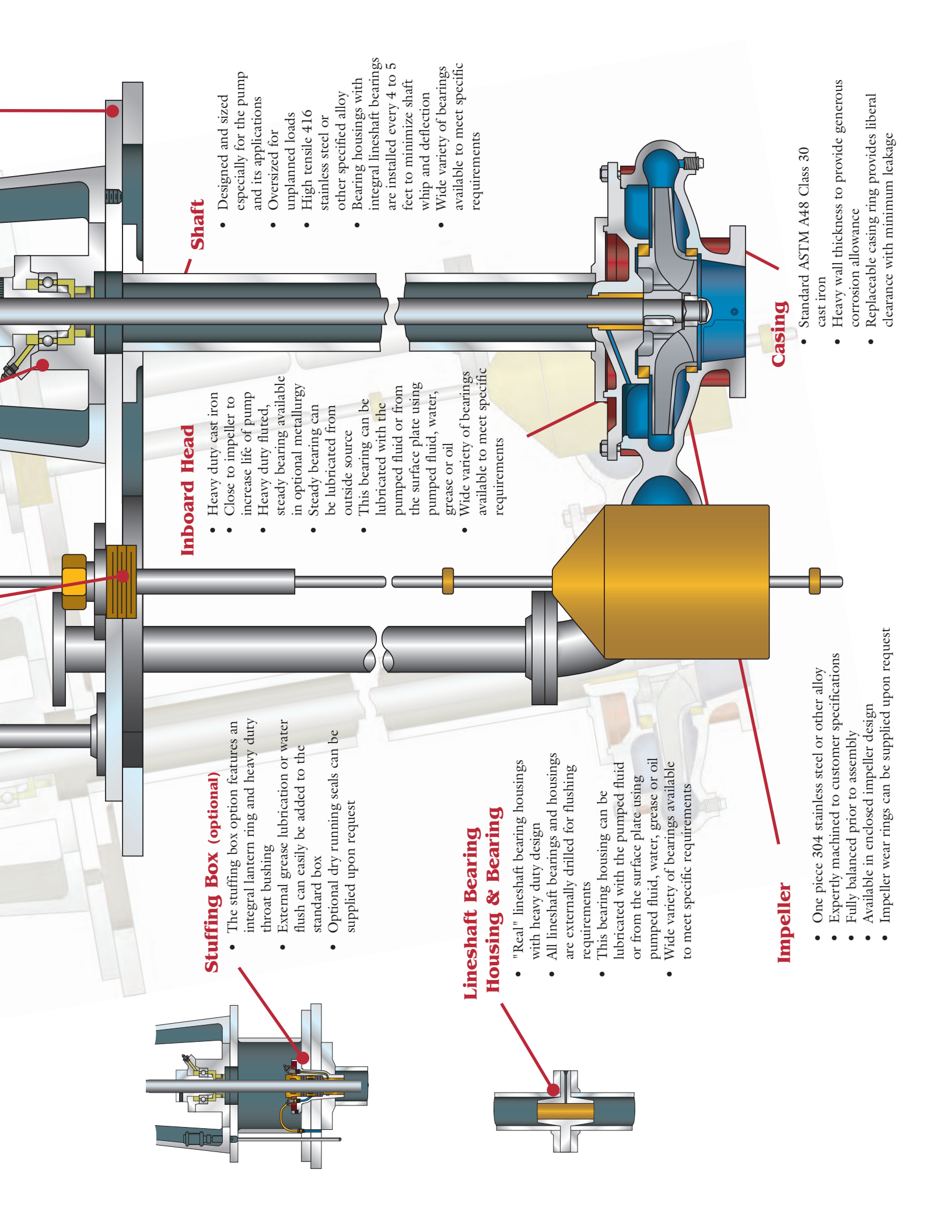

Stuffing Box (optional)

- The stuffing box option features an integral lantern ring and heavy duty throat bushing
- External grease lubrication or water flush can easily be added to the standard box
- Optional dry running seals can be supplied upon request

Inboard Head

- Heavy duty cast iron
- Close to impeller to increase life of pump
- Heavy duty fluted, steady bearing available in optional metallurgy
- Steady bearing can be lubricated from outside source
- This bearing can be lubricated with the pumped fluid or from the surface plate using pumped fluid, water, grease or oil
- Wide variety of bearings available to meet specific requirements

Shaft

- Designed and sized especially for the pump and its applications
- Oversized for unplanned loads
- High tensile 416 stainless steel or other specified alloy
- Bearing housings with integral lineshaft bearings are installed every 4 to 5 feet to minimize shaft whip and deflection
- Wide variety of bearings available to meet specific requirements

Lineshaft Bearing Housing & Bearing

- "Real" lineshaft bearing housings with heavy duty design
- All lineshaft bearings and housings are externally drilled for flushing requirements
- This bearing housing can be lubricated with the pumped fluid or from the surface plate using pumped fluid, water, grease or oil
- Wide variety of bearings available to meet specific requirements

Impeller

- One piece 304 stainless steel or other alloy
- Expertly machined to customer specifications
- Fully balanced prior to assembly
- Available in enclosed impeller design
- Impeller wear rings can be supplied upon request

Casing

- Standard ASTM A48 Class 30 cast iron
- Heavy wall thickness to provide generous corrosion allowance
- Replaceable casing ring provides liberal clearance with minimum leakage

Model SOSM Vertical Process Sump

Flows To: 7,400 GPM
 Heads To: 985 Feet
 Temps To: 400° F
 Pit Depths: 25' Settings



Reverse Vane Impeller



Semi-Open Impeller



Low Flow Impeller

Markets:

-  Chemical
-  Food & Beverage
-  General Industry
-  Marine
-  Mining & Aggregate
-  Oil & Gas
-  Power Generation
-  Petro-Chemical
-  Pharmaceutical
-  Pulp & Paper
-  Water & Wastewater

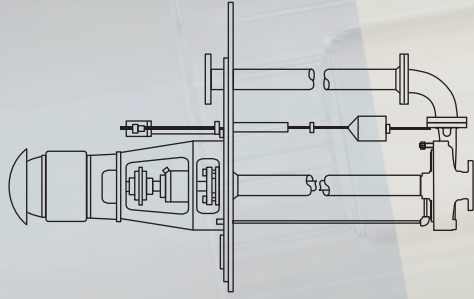

Motor

- Stocked C-face for quick delivery

Thrust Bearing Housing

- Integral thrust bearing housing featuring simplex bearing or optional duplex bearing
- Optional stuffing box

Teardrop Baseplate

- Eliminates removing entire coverplate for servicing pump
- Motor pedestal, thrust bearing housing, discharge pipe, optional float switch and optional stuffing box all mount to baseplate

Float Rod Stuffing Box (optional)

- Used for gas tight applications
- Constructed of bronze or other specified alloy

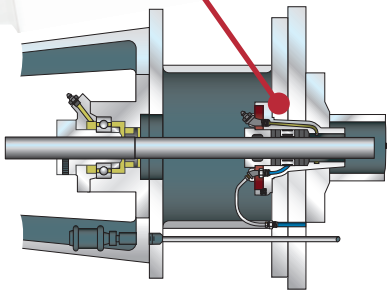

Stuffing Box (optional)

- The stuffing box option features an integral lantern ring and heavy duty throat bushing
- External grease lubrication or water flush can easily be added to the standard box
- Optional dry running seals can be supplied upon request

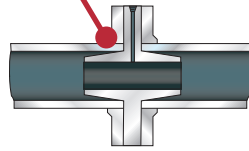

Lineshaft Bearing Housing & Bearing

- "Real" lineshaft bearing housings with heavy duty design
- All lineshaft bearings and housings are externally drilled for flushing requirements
- This bearing housing can be lubricated with the pumped fluid or from the surface plate using pumped fluid, water, grease or oil
- Wide variety of bearings available to meet specific requirements

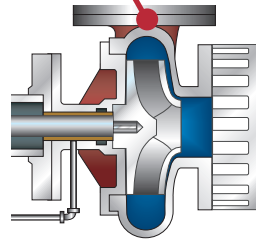

SNCM (option)

- Impeller is one piece casted in cast iron or other specified alloy and expertly machined to customer specifications
- High efficiency tangential casing casted in cast iron or other specified alloy

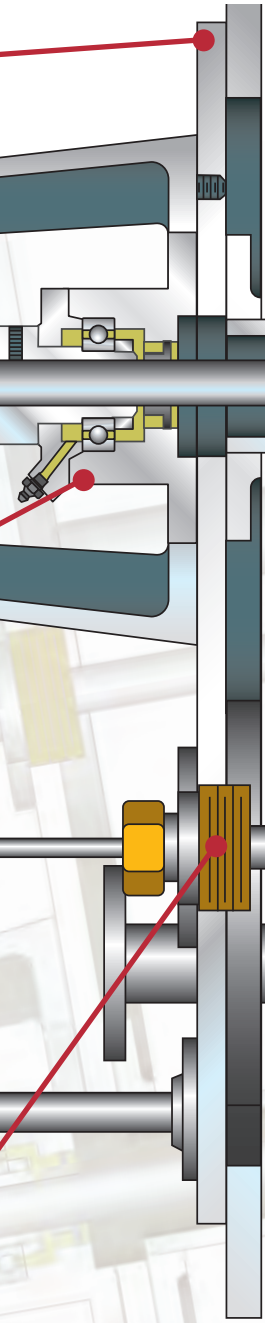

Inboard Head

- Heavy duty cast steel or other specified alloy
- Close to impeller to increase life of pump
- Heavy duty fluted, steady bearing available in optional metallurgy
- Steady bearing can be lubricated from outside source
- Wide variety of bearing available to meet specific requirements

Shaft

- Designed and sized especially for the pump and its applications
- Oversized for unplanned loads
- High tensile 416 stainless steel or other specified alloy
- Bearing housings with integral lineshaft bearings are installed every 4 to 5 feet to minimize shaft whip and deflection
- Wide variety of bearing available to meet specific requirements

Casing

- Standard cast steel or other specified alloy
- Heavy wall thickness to provide generous corrosion allowance

Impeller

- One piece cast steel or other specified alloy
- Expertly machined to customer specifications
- Fully balanced prior to assembly
- Impellers are available in Reverse Vane, Semi-Open and Low-Flow designs
- Impeller wear rings can be supplied upon request

Our long tradition of quality pump manufacturing began in 1873 making us one of the first pump manufacturers in this country. **American-Marsh Pumps** provides the user dependability and durability. Durability by design is always the most cost effective solution.

SHAFTS

American-Marsh Pumps standard product design includes 416 stainless steel shafts designed for minimum shaft deflection in high temperature environments. Each shaft is machined to close tolerances and designed to exceed HP requirements of each pump.

WEAR RINGS

Impeller and case wear rings are oversized with large wearing surfaces to extend the life of each pump. Rings are available in bronze, iron, stainless steel or other alloys as required.

IMPELLER

Impellers are one piece 304 stainless steel or other alloy expertly machined to customer specifications. Back pump out vanes or rear case wear ring prohibit material from building up behind impeller.

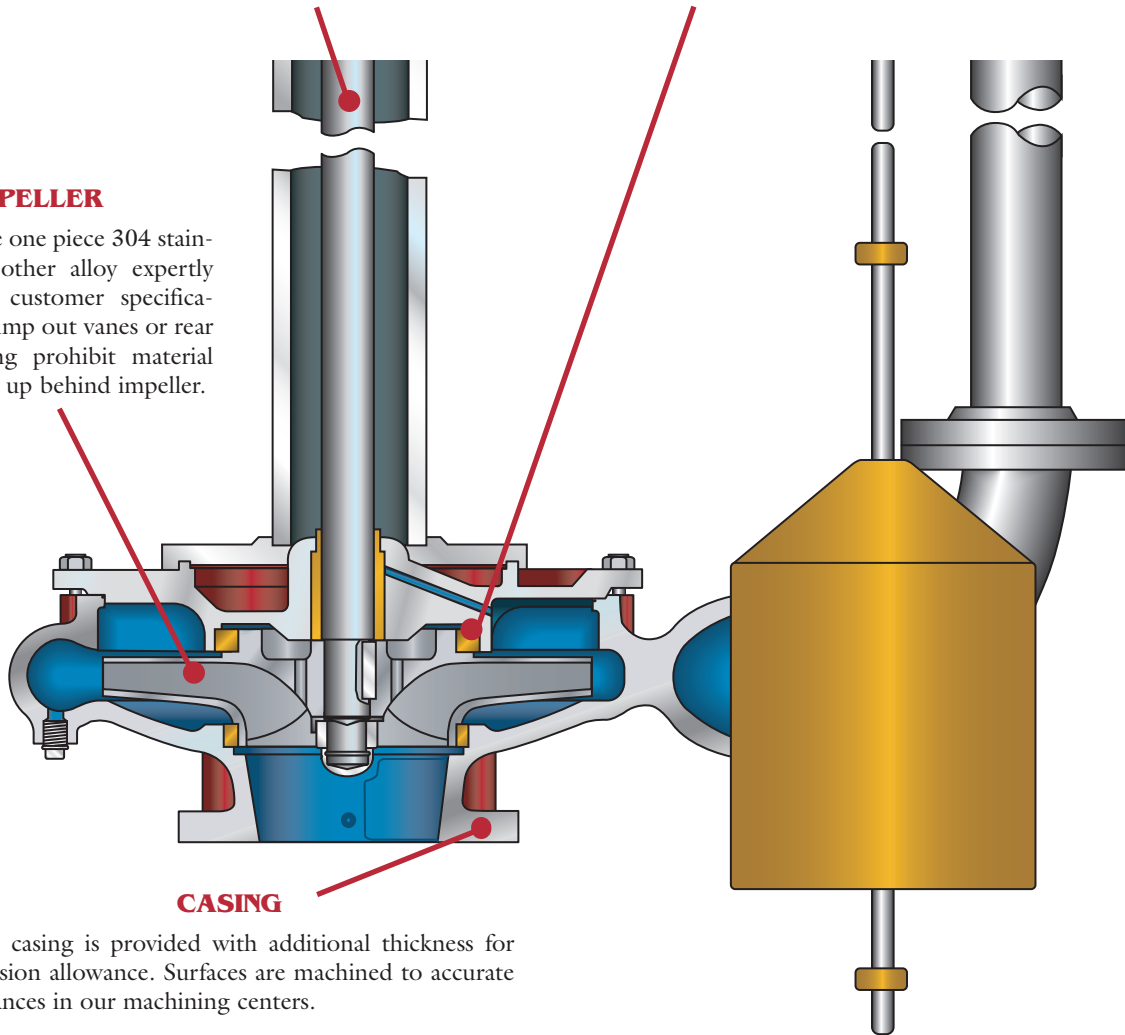

CASING

The casing is provided with additional thickness for corrosion allowance. Surfaces are machined to accurate tolerances in our machining centers.

OTHER PUMP PRODUCTS

SPLIT CASE To 32+ " Discharge 30,000+ GPM, 550'	VERTICAL TURBINE To 42+ " Bowl 85,000+ GPM, 2500'	SELF PRIMER To 12" Discharge 6400 GPM, 200'	REGENERATIVE TURBINE To 2-1/2" Discharge 140 GPM, Heads to 750'	END SUCTION To 12" Discharge 9000 GPM, 450'
--	--	--	--	--

American-Marsh Pumps
185 Progress Road
Collierville, TN 38017
PH: (800)888-7167
FX: (901)860-2323

Distribution/Service Centers:
Nebraska: 2599 South Cornhusker Avenue, Hastings, NE 68901 (800)408-7167
California: 3269 East North Building D, Fresno, CA 93725 (800)288-7167
Florida: 2805 Badger Road, Lakeland, FL 33811 (800)444-7167
Louisiana: 1626 Walker Road, Scott, LA 70583 (800)506-7167
www.american-marsh.com