



BALL VALVE CATALOG

**BRASS, STAINLESS, SANITARY, AND FIRE SAFE BALL VALVES
PNEUMATIC AND ELECTRIC ACTUATORS
AUTOMATION ACCESSORIES AND CUSTOMIZED HARDWARE**















ANYTHING'S POSSIBLE... JUST ASK!
BITORQ.COM

TABLE OF CONTENTS

ANYTHING'S POSSIBLE... JUST ASK!

IP SERIES BRASS	4-5
IP-3W 3-WAY BRASS	6-7
IS-2P 2-PC STAINLESS	8-9
IS-3PT 3-PC STAINLESS	10-11
FS/FW FIRESAFE	12-13
IS-2PF FLANGED STAINLESS	14-15
IS-3TC SANITARY	16-17
IS-3WTC SANITARY 3-WAY	18-19
IS-3W 3-WAY	20-21
IS-3WF 3-WAY FLANGED	22-23
IC/IV PVC/CPVC	24-25
IC/IV-3W 3-WAY PVC/CPVC	26-27
PART NUMBER GUIDE	28
3-WAY FLOW DIAGRAMS	29
ACTUATORS	30
ACCESSORIES	31

<p>IP-2P AND IB-2P SERIES</p>  <p><i>2-PIECE NPT ENDS BRASS VALVES 1/4" TO 4"</i></p>	<p>IS-3TC SERIES</p>  <p><i>CAVITY-FILLED CLAMP ENDS SANITARY VALVES 1/2" TO 4"</i></p>
<p>IP-3W SERIES</p>  <p><i>3-WAY NPT ENDS BRASS VALVES 1/4" TO 3"</i></p>	<p>IS-3WTC SERIES</p>  <p><i>3-WAY CLAMP ENDS SANITARY VALVES 1/2" TO 2"</i></p>
<p>IS-2P SERIES</p>  <p><i>2-PIECE NPT ENDS SS VALVES 1/4" TO 3"</i></p>	<p>IS-3W SERIES</p>  <p><i>3-WAY NPT/SW ENDS SS VALVES 1/2" TO 2"</i></p>
<p>IS-3PT SERIES</p>  <p><i>3-PIECE NPT/SW ENDS SS VALVES 1/4" TO 3"</i></p>	<p>IS-3WF SERIES</p>  <p><i>3-WAY 150# FLANGED SS VALVES 1/2" TO 4"</i></p>
<p>FS-3P AND FW-3P SERIES</p>  <p><i>FIRE SAFE NPT/SW ENDS SS OR WCB VALVES 1/4" TO 2"</i></p>	<p>IC-3P AND IV-3P SERIES</p>  <p><i>TRUE UNION NPT/SW ENDS PVC OR CPVC VALVES 1/2" TO 4"</i></p>
<p>IS-2PF SERIES</p>  <p><i>150# FLANGED SS VALVES 1/2" TO 6" OPTIONAL FIRE SAFE</i></p>	<p>IC-3W SERIES</p>  <p><i>3-WAY NPT/SW ENDS PVC VALVES 1/2" TO 2"</i></p>

ALL BI-TORQ INSTRUPAK SERIES ARE AVAILABLE AS MANUAL VALVES*

* IP SERIES AUTOMATED VALVES AND MP SERIES (NO AUTOMATION PAD) MANUAL VALVES ARE A DIFFERENT DESIGN

IP-2P & IB-2P SERIES 2-PC BRASS BALL VALVES

PNEUMATIC ACTUATORS

PNEUMATIC FEATURES

- Rack and pinion design
- NAMUR accessory mounting
- Spring return and double acting
- Visual indicators
- Optional SS construction

ALL STANDARD ACTUATORS SIZED FOR 80 PSI AIR SUPPLY; PLEASE CONSULT FACTORY FOR OTHER COMBINATIONS

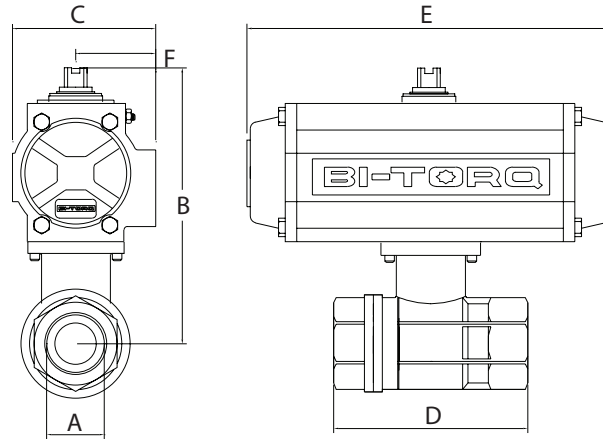

FOR A LIST OF AUTOMATION ACCESSORIES WE CAN OFFER, PLEASE REFER TO PAGE 31 OR VISIT BITORQ.COM

DOUBLE ACTING ASSEMBLY DIMENSIONS							
A	B	C	D	E	F	ACT.	WT.
1/4"	4.80	2.79	2.64	5.49	1.61	52SR	3.33
3/8"	4.80	2.79	2.64	5.49	1.61	52SR	3.43
1/2"	4.45	2.79	2.60	5.49	1.61	52SR	3.47
3/4"	4.52	2.79	2.93	5.49	1.61	52SR	3.56
1"	4.86	2.79	3.56	5.49	1.61	52SR	4.00
1-1/4"	5.44	3.17	4.09	6.38	1.77	63SR	4.87
1-1/2"	5.94	3.17	4.61	6.38	1.77	63SR	7.12
2"	6.30	3.17	5.31	6.38	1.77	63SR	9.43
2-1/2"	7.81	4.17	6.10	9.35	2.30	85SR	18.16
3"	8.70	4.85	6.89	10.69	2.68	100SR	23.18
4"	9.43	4.85	8.86	10.69	2.68	100SR	31.32

SPRING RETURN ASSEMBLY DIMENSIONS							
A	B	C	D	E	F	ACT.	WT.
1/4"	3.84	1.77	2.64	4.65	0.89	32DA	1.73
3/8"	3.84	1.77	2.64	4.65	0.89	32DA	1.83
1/2"	3.49	1.77	2.60	4.65	0.89	32DA	1.87
3/4"	3.56	1.77	2.93	4.65	0.89	32DA	1.95
1"	3.90	1.77	3.56	4.65	0.89	32DA	2.40
1-1/4"	5.44	3.17	4.09	6.38	1.77	63DA	3.27
1-1/2"	5.94	3.17	4.61	6.38	1.77	63DA	5.47
2"	6.30	3.17	5.31	6.38	1.77	63DA	7.78
2-1/2"	7.36	3.72	6.10	8.15	2.07	75DA	8.78
3"	7.74	3.72	6.89	8.15	2.07	75DA	18.41
4"	8.92	4.17	8.86	9.35	2.30	85DA	26.37

ELECTRIC ACTUATORS

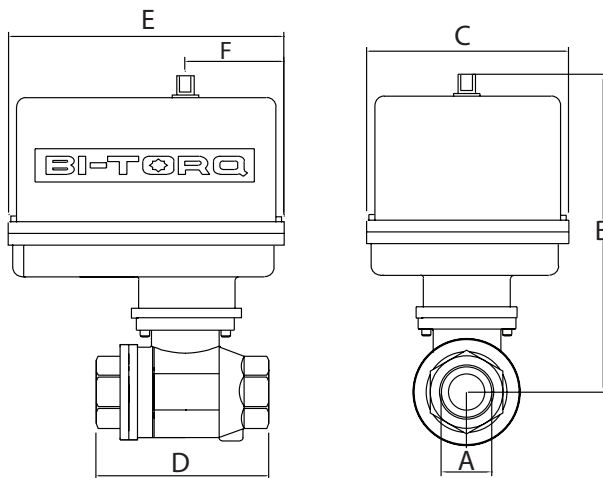

NEMA 4 ELECTRIC ASSEMBLY DIMENSIONS							
A	B	C	D	E	F	ACT.	WT.
1/4"	6.16	4.00	2.64	5.63	2.31	100E	5.68
3/8"	6.16	4.00	2.64	5.63	2.31	100E	5.78
1/2"	5.81	4.00	2.6	5.63	2.31	100E	5.82
3/4"	5.88	4.00	2.93	5.63	2.31	100E	5.91
1"	6.22	4.00	3.56	5.63	2.31	100E	6.35
1-1/4"	7.36	4.25	4.09	6.88	2.43	200E	7.22
1-1/2"	7.86	4.25	4.61	6.88	2.43	200E	10.17
2"	8.22	4.25	5.31	6.88	2.43	200E	12.48
2-1/2"	8.63	4.25	6.1	6.88	2.43	300E	15.66
3"	11.13*	7.00	6.89	7.00	2.38	400E	26.68
4"	11.86*	7.00	8.86	7.00	2.38	675E	29.87

* DECLUTCHABLE MANUAL OVERRIDE INCLUDED IN DIMENSIONS

ELECTRIC FEATURES

- 120VAC, 220VAC, 24VAC, 12VDC and 24VDC
- NEMA 4, 4X and 7 housings
- Manual overrides
- Visual indicators
- Open/close or modulating service

FOR NEMA 7 ELECTRIC DIMENSIONS OR OTHER CONFIGURATIONS, CONTACT OUR SALES STAFF.

FOR MORE INFORMATION ON BI-TORQ ACTUATORS, REFER TO OUR INDIVIDUAL PNEUMATIC AND ELECTRIC CATALOGS, OR VISIT BITORQ.COM.

IP-2P & IB-2P SERIES 2-PC BRASS BALL VALVES

BILL OF MATERIALS

PART #	NAME	MATERIAL	OPTIONAL MATERIAL*	QTY
1	BODY	BRASS UNI 5705-65	N/A	1
2	ENDS	BRASS UNI 5705-65	N/A	2
3	BALL	BRASS UNI 5705-65 CHROME PLATED	316SS	1
4	SEAT	TFE	N/A	2
5	BODY SEAL	VITON	N/A	2
6	STEM SEAL	TFE	N/A	1
7	BODY O-RING	VITON	N/A	2
8	STEM O-RING	VITON	N/A	1
9	STEM NUT	BRASS UNI 5705-65	316SS	1
10	STEM	BRASS UNI 5705-65	316SS	1

VALVE FEATURES

- Full port design brass valve
- IB series: 316SS ball/stem to 2"
- 1/4" through 4" NPT size range
- TFE® seats and seals
- Viton® body o-rings
- Vacuum to 29 inHg
- Blow-out proof stem
- CE rated
- ISO mounting pad

PRESSURE RATING
600 PSI CWP
TEMPERATURE RATING
+297° F Maximum

NOTE: MAXIMUM TEMPERATURE RATING FOR STANDARD ACTUATORS IS 150° F (ELECTRIC) AND 180° (PNEUMATIC). SPECIAL SEALS OR HEAT EXTENSIONS ARE AVAILABLE FOR HIGH TEMPERATURE SERVICE.

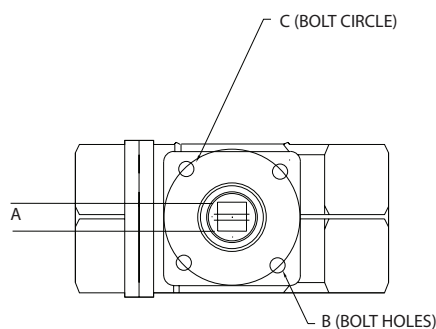

NOTE: STEM SQUARE IS AT 45° ON 1/4", 3/8", 2-1/2", 3", 4" SIZES

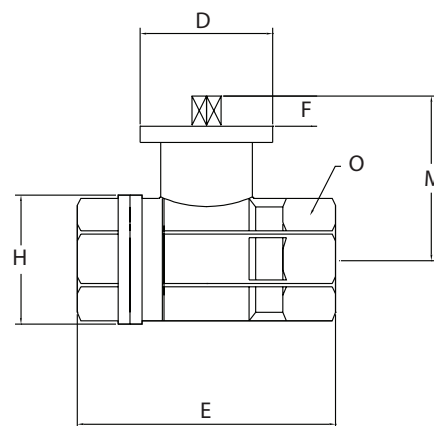
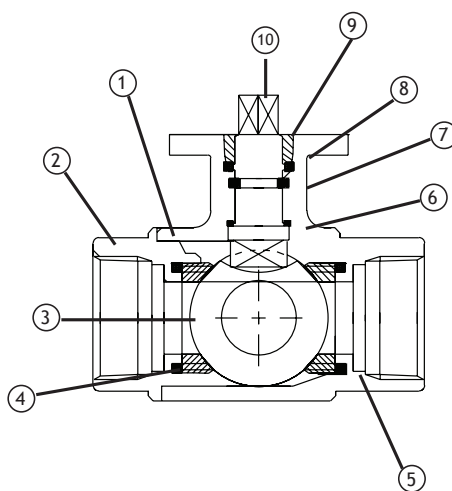

DIMENSIONAL DATA

SIZE	ISO 5211	A	B	C	D	E	F	H	M	O	CV	WT.
1/4"	F03	0.35	0.24	1.42	1.49	2.64	0.35	1.32	1.63	1.06	6.29	0.82
3/8"	F03	0.35	0.24	1.42	1.49	2.64	0.35	1.32	1.63	1.06	6.99	0.79
1/2"	F03	0.35	0.22	1.42	1.49	2.59	0.30	1.31	1.51	1.06	19	0.82
3/4"	F03	0.35	0.22	1.42	1.49	2.93	0.33	1.57	1.85	1.26	19	0.91
1"	F03	0.35	0.22	1.42	1.49	3.56	0.33	1.92	2.00	1.61	34.5	1.35
1-1/4"	F03	0.55	0.26	1.97	1.49	4.09	0.57	2.30	2.75	1.97	50.2	2.22
1-1/2"	F05	0.55	0.26	1.97	1.96	4.61	0.57	2.81	3.01	2.17	268.4	3.17
2"	F05	0.55	0.26	1.97	1.96	5.31	0.57	3.60	3.286	2.76	309.3	5.48
2-1/2"	F07	0.55	0.25	2.76	2.75	6.10	0.59	4.45	3.34	3.54	629.5	8.66
3"	F07	0.55	0.33	2.76	2.75	6.89	0.59	5.31	3.72	4.13	944.5	13.68
4"	F07	0.67	0.33	2.76	2.75	8.86	0.70	6.53	4.56	5.11	1493	16.87

BI-TORQ'S MANUAL BRASS VALVE SERIES (MP-2P) IS A DIFFERENT DESIGN AND DOES NOT HAVE A MOUNTING PAD, PLEASE CONSULT SALES FOR DIMENSIONS

ALL VALVES ARE 100% ELECTRONICALLY TESTED AT 80 PSI IN BOTH THE OPEN AND CLOSED POSITIONS

IP-3W SERIES STANDARD PORT 3-WAY BRASS BALL VALVES

PNEUMATIC ACTUATORS

PNEUMATIC FEATURES

- Rack and pinion design
- NAMUR accessory mounting
- Spring return and double acting
- Visual indicators
- Optional SS construction

ALL STANDARD ACTUATORS SIZED FOR 80 PSI AIR SUPPLY; PLEASE CONSULT FACTORY FOR OTHER COMBINATIONS

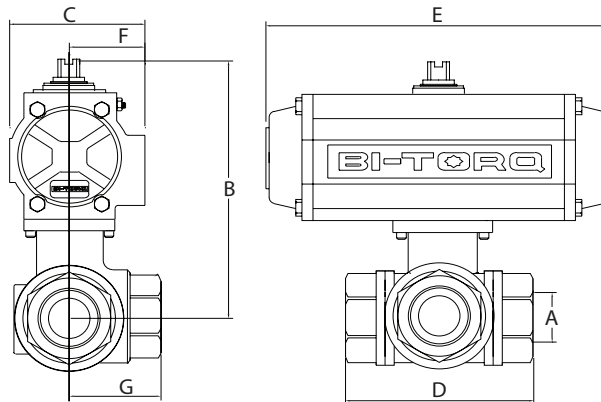

FOR A LIST OF AUTOMATION ACCESSORIES WE CAN OFFER, PLEASE REFER TO PAGE 31 OR VISIT BITORQ.COM

DOUBLE ACTING ASSEMBLY DIMENSIONS								
A	B	C	D	E	F	G	ACT.	WT.
1/4"	3.76	1.77	2.64	4.65	0.89	1.32	32DA	2.02
3/8"	3.76	1.77	2.64	4.65	0.89	1.32	32DA	2.02
1/2"	3.76	1.77	2.87	4.65	0.89	1.44	32DA	2.20
3/4"	3.85	1.77	3.19	4.65	0.89	1.60	32DA	2.85
1"	5.15	2.79	3.74	5.49	1.61	1.87	52DA	5.63
1-1/4"	5.37	2.79	4.39	5.49	1.61	2.20	52DA	7.63
1-1/2"	5.51	3.17	4.86	6.38	1.77	2.43	63DA	11.96
2"	6.62	3.72	5.73	8.15	2.07	2.87	75DA	15.70
2-1/2"	7.07	3.72	6.93	8.15	2.07	3.47	75DA	21.93
3"	7.07	3.72	7.08	8.15	2.07	3.54	75DA	25.15

SPRING RETURN ASSEMBLY DIMENSIONS								
A	B	C	D	E	F	G	ACT.	WT.
1/4"	4.72	2.79	2.64	5.49	1.61	1.32	52SR	3.27
3/8"	4.72	2.79	2.64	5.49	1.61	1.32	52SR	3.27
1/2"	4.72	2.79	2.87	5.49	1.61	1.44	52SR	3.80
3/4"	4.81	2.79	3.19	5.49	1.61	1.60	52SR	4.45
1"	5.59	3.17	3.74	6.38	1.77	1.87	63SR	7.28
1-1/4"	5.81	3.17	4.39	6.38	1.77	2.20	63SR	9.28
1-1/2"	6.95	3.72	4.86	8.15	2.07	2.43	75SR	15.71
2"	7.96	4.17	5.73	9.35	2.30	2.87	85SR	19.6
2-1/2"	8.92	4.85	6.93	10.69	2.68	3.47	100SR	30.78
3"	8.92	4.85	7.08	10.69	2.68	3.54	100SR	34.00

ELECTRIC ACTUATORS

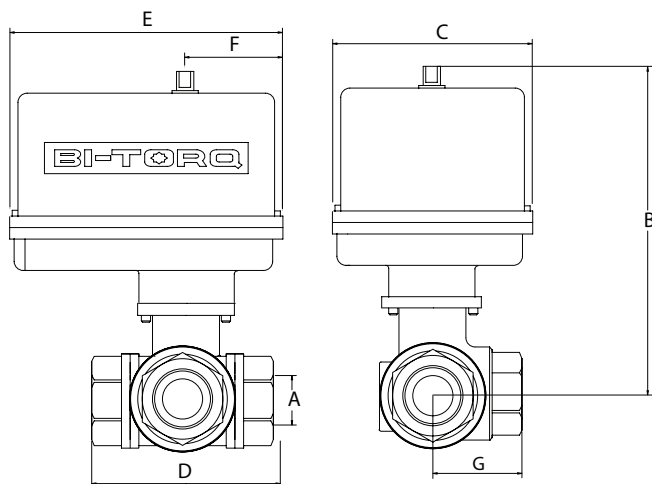

NEMA 4 ELECTRIC DIMENSIONS								
A	B	C	D	E	F	G	ACT.	WT.
1/4"	6.08	4.00	2.64	5.63	2.30	1.32	100E	5.97
3/8"	6.08	4.00	2.64	5.63	2.30	1.32	100E	5.97
1/2"	6.08	4.00	2.87	5.63	2.30	1.44	100E	6.15
3/4"	6.17	4.00	3.19	5.63	2.30	1.60	100E	6.80
1"	7.51	4.25	3.74	6.88	2.30	1.87	200E	10.33
1-1/4"	7.73	4.25	4.39	6.88	2.43	2.20	200E	12.33
1-1/2"	8.22	4.25	4.86	6.88	2.43	2.43	200E	15.66
2"	8.78	4.25	5.73	6.88	2.43	2.87	300E	17.10
2-1/2"	11.35*	7.00	6.93	7.00	2.38	3.47	400E	29.33
3"	11.35*	7.00	7.08	7.00	2.38	3.54	400E	32.55

* DECLUTCHABLE MANUAL OVERRIDE INCLUDED IN DIMENSIONS

ELECTRIC FEATURES

- 120VAC, 220VAC, 24VAC, 12VDC and 24VDC
- NEMA 4, 4X and 7 housings
- Manual overrides
- Visual indicators
- Open/close or modulating service

FOR NEMA 7 ELECTRIC DIMENSIONS OR OTHER CONFIGURATIONS, CONTACT OUR SALES STAFF.

FOR MORE INFORMATION ON BI-TORQ ACTUATORS, REFER TO OUR INDIVIDUAL PNEUMATIC AND ELECTRIC CATALOGS, OR VISIT BITORQ.COM.

IP-3W SERIES STANDARD PORT 3-WAY BRASS BALL VALVES

BILL OF MATERIALS

PART #	NAME	MATERIAL	QTY
1	BODY	BRASS UNI 5705-65	1
2	ENDS	BRASS UNI 5705-65	3
3	BALL	BRASS UNI 5705-65 CHROME PLATED	1
4	SEAT	TFE	4
5	BODY SEAL	VITON	4
6	STEM SEAL	TFE	1
7	BODY O-RING	VITON	1
8	STEM O-RING	VITON	1
9	STEM NUT	BRASS UNI 5705-65	1
10	STEM	BRASS UNI 5705-65	1

VALVE FEATURES

- Standard port brass valve
- 1/4" through 2"
- Multiple flow configurations
- TFE® seats and seals
- Viton® body o-rings
- ISO mounting pad
- Blowout proof stem
- 4-seat design

PRESSURE RATING
600 PSI CWP
TEMPERATURE RATING
+297° F Maximum

NOTE: MAXIMUM TEMPERATURE RATING FOR STANDARD ACTUATORS IS 150° F (ELECTRIC) AND 180° (PNEUMATIC). SPECIAL SEALS OR HEAT EXTENSIONS ARE AVAILABLE FOR HIGH TEMPERATURE SERVICE.

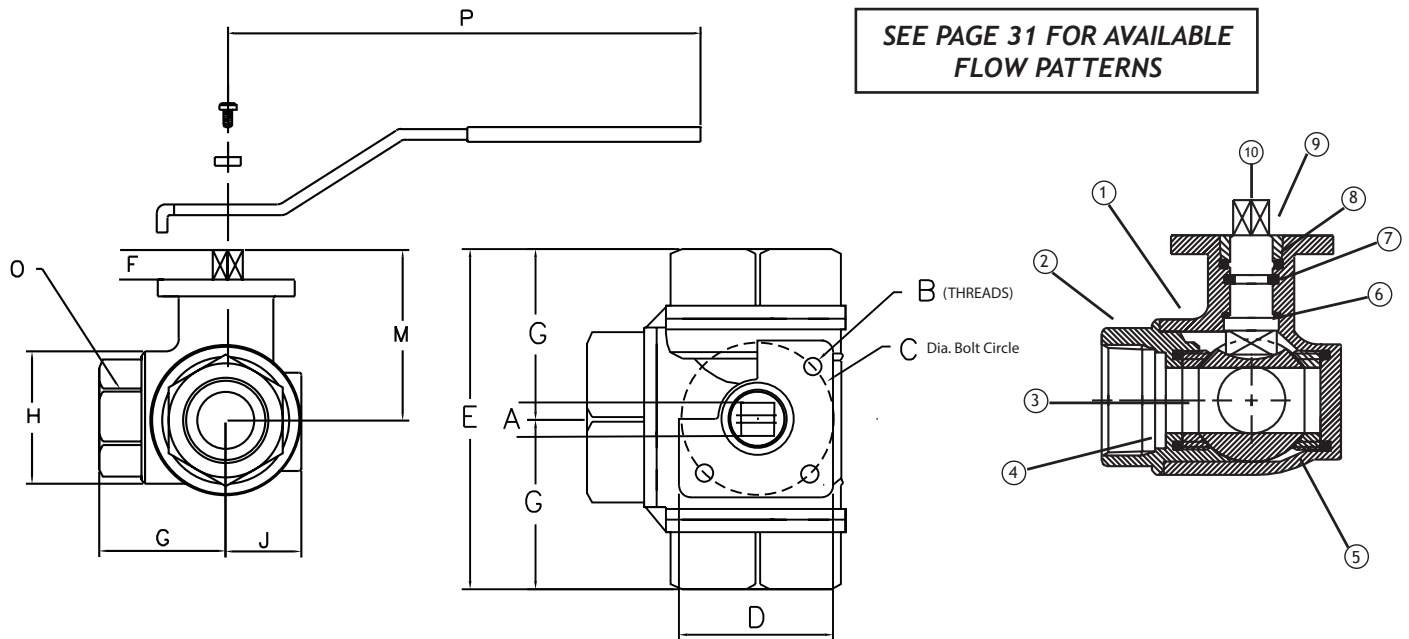

DIMENSIONAL DATA

SIZE	ISO 5211	A	B	C	D	E	F	G	H	J	M	O	P	CV	WT.
1/4"	F03	0.35	0.23	1.41	0.39	2.64	0.35	1.32	1.34	0.77	1.55	0.86	4.72	3.26	1.22
3/8"	F03	0.35	0.23	1.41	0.43	2.64	0.35	1.32	1.34	0.77	1.55	0.86	4.72	3.50	1.16
1/2"	F03	0.35	0.23	1.41	0.43	2.87	0.35	1.44	1.34	0.77	1.55	1.06	4.72	4.20	1.21
3/4"	F03	0.35	0.23	1.41	0.59	3.19	0.35	1.60	1.53	0.87	1.64	1.25	4.72	7.00	1.44
1"	F05	0.43	0.27	1.96	0.78	3.74	0.43	1.87	1.89	1.00	2.06	1.61	6.69	12.83	2.64
1-1/4"	F05	0.43	0.27	1.96	0.98	4.39	0.43	2.20	2.36	1.22	2.28	1.96	6.69	18.67	4.15
1-1/2"	F05	0.43	0.27	1.96	1.26	4.86	0.43	2.43	2.83	1.79	2.77	2.16	6.69	29.75	6.02
2"	F07	0.55	0.35	2.76	1.57	5.73	0.59	2.87	3.38	1.75	3.49	2.75	9.05	43.76	9.08
2-1/2"	F07	0.55	0.35	2.76	1.95	6.93	0.59	3.47	4.37	2.20	3.94	3.34	9.05	70.00	16.33
3"	F07	0.55	0.35	2.76	1.95	7.08	0.59	3.54	4.45	2.20	3.94	4.13	9.05	110	19.55

THE MANUAL VERSION OF THIS MODEL STARTS WITH AN "M"

ALL VALVES ARE 100% ELECTRONICALLY TESTED AT 80 PSI IN BOTH THE OPEN AND CLOSED POSITIONS

IS-2P SERIES 2-PC STAINLESS STEEL BALL VALVES

PNEUMATIC ACTUATORS

PNEUMATIC FEATURES

- Rack and pinion design
- NAMUR accessory mounting
- Spring return and double acting
- Visual indicators
- Optional SS construction

ALL STANDARD ACTUATORS SIZED FOR 80 PSI AIR SUPPLY; PLEASE CONSULT FACTORY FOR OTHER COMBINATIONS

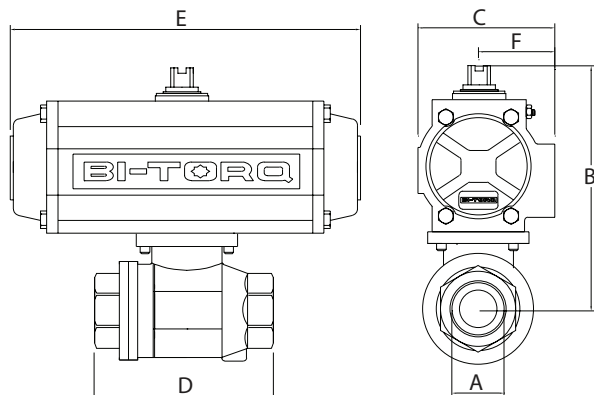

FOR A LIST OF AUTOMATION ACCESSORIES WE CAN OFFER, PLEASE REFER TO PAGE 31 OR VISIT BITORQ.COM

DOUBLE ACTING ASSEMBLY DIMENSIONS							
A	B	C	D	E	F	ACT.	WT.
1/4"	3.94	1.77	2.36	4.65	0.89	32DA	1.93
3/8"	3.94	1.77	2.36	4.65	0.89	32DA	1.93
1/2"	3.94	1.77	2.72	4.65	0.89	32DA	2.00
3/4"	4.10	1.77	3.15	4.65	0.89	32DA	2.50
1"	5.29	2.79	3.54	5.49	1.61	52DA	4.66
1-1/4"	5.95	3.17	4.17	6.38	1.77	63DA	5.80
1-1/2"	6.58	3.17	4.72	6.38	1.77	63DA	7.51
2"	6.95	3.17	5.51	6.38	1.77	63DA	11.20
2-1/2"	9.19	4.17	6.61	9.35	2.30	85DA	25.10
3"	10.14	4.85	7.48	10.69	2.68	100DA	36.45

SPRING RETURN ASSEMBLY DIMENSIONS							
A	B	C	D	E	F	ACT.	WT.
1/4"	4.90	2.79	2.36	5.49	1.61	52SR	3.53
3/8"	4.90	2.79	2.36	5.49	1.61	52SR	3.53
1/2"	4.90	2.79	2.72	5.49	1.61	52SR	3.6
3/4"	5.06	2.79	3.15	5.49	1.61	52SR	4.1
1"	5.73	3.17	3.54	6.38	1.77	63SR	6.31
1-1/4"	5.95	3.17	4.17	6.38	1.77	63SR	7.45
1-1/2"	7.23	3.72	4.72	8.15	2.07	75SR	11.26
2"	8.56	4.85	5.51	10.69	2.68	100SR	19.38
2-1/2"	10.88	5.39	6.61	12.91	2.87	115SR	39.95
3"	11.79	5.83	7.48	14.41	3.15	125SR	54.8

ELECTRIC ACTUATORS

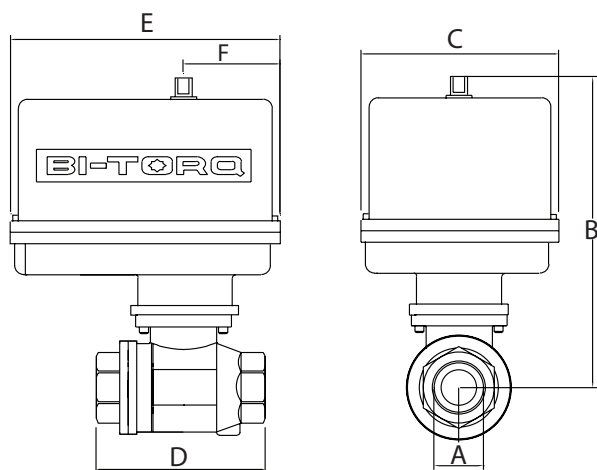

NEMA 4 ELECTRIC ASSEMBLY DIMENSIONS							
A	B	C	D	E	F	ACT.	WT.
1/4"	6.58	4.00	2.36	5.63	2.31	100E	5.88
3/8"	6.58	4.00	2.36	5.63	2.31	100E	5.88
1/2"	6.58	4.00	2.72	5.63	2.31	100E	5.95
3/4"	6.65	4.00	3.15	5.63	2.31	100E	6.45
1"	7.98	4.25	3.54	6.88	2.43	200E	9.36
1-1/4"	8.12	4.25	4.17	6.88	2.43	200E	10.50
1-1/2"	8.55	4.25	4.72	6.88	2.43	200E	11.21
2"	8.88	4.25	5.51	6.88	2.43	300E	14.90
2-1/2"	11.90*	7.00	6.61	7.00	2.38	675E	30.6
3"	12.40*	7.00	7.48	7.00	2.38	1000E	38.30

* DECLUTCHABLE MANUAL OVERRIDE INCLUDED IN DIMENSIONS

ELECTRIC FEATURES

- 120VAC, 220VAC, 24VAC, 12VDC and 24VDC
- NEMA 4, 4X and 7 housings
- Manual overrides
- Visual indicators
- Open/close or modulating service

FOR NEMA 7 ELECTRIC DIMENSIONS OR OTHER CONFIGURATIONS, CONTACT OUR SALES STAFF.

FOR MORE INFORMATION ON BI-TORQ ACTUATORS, REFER TO OUR INDIVIDUAL PNEUMATIC AND ELECTRIC CATALOGS, OR VISIT BITORQ.COM.

IS-2P SERIES 2-PC STAINLESS STEEL BALL VALVES

BILL OF MATERIALS

PART #	NAME	MATERIAL	QTY
1	BODY	ASTM A351 GR CF8M	1
2	ENDS	ASTM A351 GR CF8M	2
3	BALL	316SS	1
4	SEAT	RTFE	2
5	BODY SEAL	PTFE	1
6	STEM	316SS	1
7	THRUST WASHER	PTFE	1
8	STEM PACKING	PTFE	1
9	GLAND NUT	304SS	1
10	BELLEVILLE WASHER	304SS	2
11	PACKING NUT	304SS	1
12	LOCK WASHER	304SS	1

VALVE FEATURES

- Full port stainless steel valve
- 1/4" through 3" size range
- RTFE® seats and TFE seals
- ISO mounting pad
- Blowout proof stem
- Low-torque design
- Spring loaded belleville washers

PRESSURE RATING
1000 PSI CWP

TEMPERATURE RATING
+400° F Maximum
-4° F Minimum

NOTE: MAXIMUM TEMPERATURE RATING FOR STANDARD ACTUATORS IS 150° F (ELECTRIC) AND 180° (PNEUMATIC). SPECIAL SEALS OR HEAT EXTENSIONS ARE AVAILABLE FOR HIGH TEMPERATURE SERVICE.

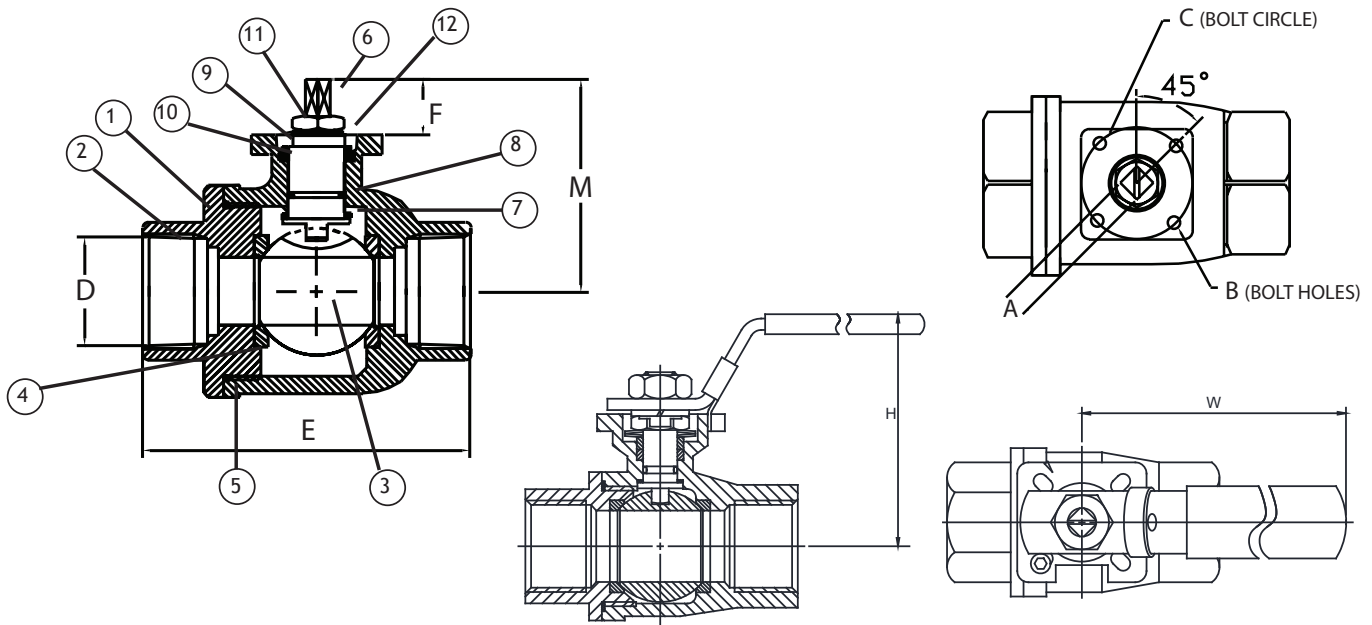

DIMENSIONAL DATA

SIZE	ISO 5211	A	B	C	D	E	F	H	M	W	CV	WT.
1/4"	F03-F04	0.35	0.28	1.42/1.65	0.43	2.36	0.39	2.83	1.77	5.31	8	0.88
3/8"	F03-F04	0.35	0.28	1.42/1.65	0.59	2.36	0.39	2.83	1.77	5.31	10	0.88
1/2"	F03-F04	0.35	0.28	1.42/1.65	0.59	2.72	0.39	2.83	1.77	5.31	13	1.05
3/4"	F03-F04	0.35	0.28	1.42/1.65	0.79	3.15	0.39	2.99	1.93	5.31	50	1.23
1"	F04-F05	0.43	0.28	1.65/1.97	1.00	3.54	0.55	3.23	2.32	6.50	93	1.65
1-1/4"	F04-F05	0.43	0.28	1.65/1.97	1.26	4.17	0.55	3.46	2.54	6.50	170	3.25
1-1/2"	F05-F07	0.55	0.28/0.35	1.97/2.76	1.50	4.72	0.77	4.09	3.39	7.68	250	5.10
2"	F05-F07	0.55	0.28/0.35	1.97/2.76	1.97	5.51	0.77	5.67	3.76	7.68	450	8.36
2-1/2"	F07-F10	0.67	0.35	2.76/4.02	2.56	6.61	0.83	6.38	4.96	11.81	750	17.60
3"	F07-F10	0.67	0.35	2.76/4.02	3.15	7.48	0.83	6.81	5.39	11.81	1300	25.30

THE MANUAL VERSION OF THIS MODEL STARTS WITH AN "M"

ALL VALVES ARE 100% ELECTRONICALLY TESTED AT 80 PSI IN BOTH THE OPEN AND CLOSED POSITIONS

IS-3P SERIES 3-PC STAINLESS STEEL BALL VALVES

PNEUMATIC ACTUATORS

PNEUMATIC FEATURES

- Rack and pinion design
- NAMUR accessory mounting
- Spring return and double acting
- Visual indicators
- Optional SS construction

ALL STANDARD ACTUATORS SIZED FOR 80 PSI AIR SUPPLY; PLEASE CONSULT FACTORY FOR OTHER COMBINATIONS

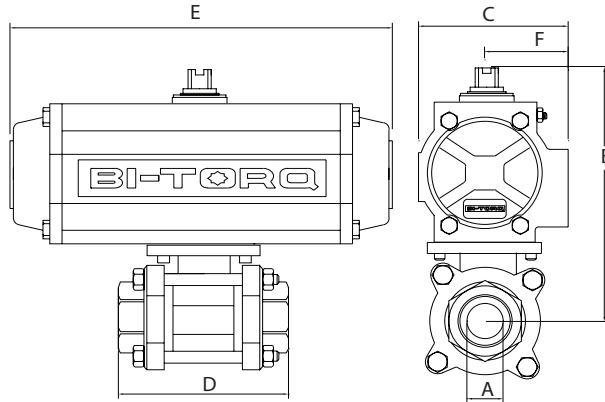

FOR A LIST OF AUTOMATION ACCESSORIES WE CAN OFFER, PLEASE REFER TO PAGE 31 OR VISIT BITORQ.COM

DOUBLE ACTING ASSEMBLY DIMENSIONS							
A	B	C	D	E	F	ACT.	WT.
1/4"	4.25	1.77	2.56	4.65	0.89	32DA	2.32
3/8"	4.25	1.77	2.56	4.65	0.89	32DA	2.32
1/2"	4.25	1.77	2.95	4.65	0.89	32DA	2.50
3/4"	4.33	1.77	3.15	4.65	0.89	32DA	2.80
1"	5.61	2.79	3.54	5.49	1.61	52DA	5.40
1-1/4"	6.20	3.17	4.33	6.38	1.77	63DA	6.65
1-1/2"	6.64	3.17	4.72	6.38	1.77	63DA	9.95
2"	6.99	3.17	5.51	6.38	1.77	63DA	13.30
2-1/2"	8.96	4.17	7.28	9.35	2.30	85DA	28.80
3"	9.94	4.85	8.07	10.69	2.68	100DA	37.50
4"	12.18	5.39	9.45	12.91	2.87	115DA	69.10

SPRING RETURN ASSEMBLY DIMENSIONS							
A	B	C	D	E	F	ACT.	WT.
1/4"	5.21	2.79	2.56	5.49	1.61	52SR	3.92
3/8"	5.21	2.79	2.56	5.49	1.61	52SR	3.92
1/2"	5.21	2.79	2.95	5.49	1.61	52SR	4.10
3/4"	5.29	2.79	3.15	5.49	1.61	52SR	4.40
1"	6.05	3.17	3.54	6.38	1.77	63SR	7.05
1-1/4"	6.1	3.17	4.33	6.38	1.77	63SR	8.30
1-1/2"	7.29	3.72	4.72	8.15	2.07	75SR	13.70
2"	8.6	4.85	5.51	10.69	2.68	100SR	24.50
2-1/2"	10.65	5.39	7.28	12.91	2.87	115SR	43.65
3"	11.12	5.39	8.07	12.91	2.87	115SR	52.35
4"	16.22	7.35	9.45	16.93	3.94	161SR	105.3

ELECTRIC ACTUATORS

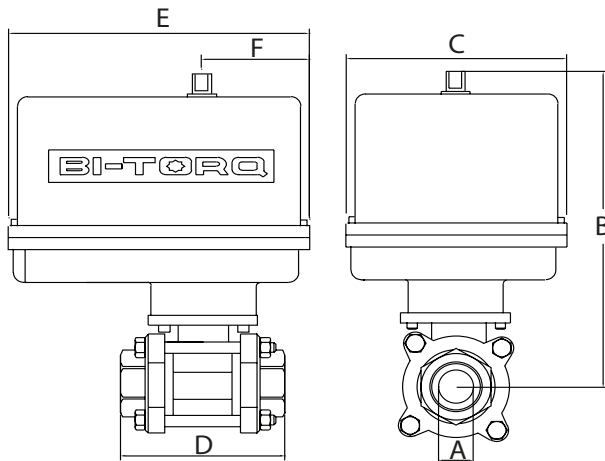

NEMA 4 ELECTRIC DIMENSIONS							
A	B	C	D	E	F	ACT.	WT.
1/4"	6.57	4.00	2.56	5.63	2.31	100E	6.27
3/8"	6.57	4.00	2.56	5.63	2.31	100E	6.27
1/2"	6.57	4.00	2.95	5.63	2.31	100E	6.45
3/4"	6.65	4.00	3.15	5.63	2.31	100E	6.75
1"	7.97	4.25	3.54	6.88	2.43	200E	10.10
1-1/4"	8.12	4.25	4.33	6.88	2.43	200E	11.35
1-1/2"	8.56	4.25	4.72	6.88	2.43	200E	13.65
2"	8.91	4.25	5.51	6.88	2.43	300E	17.00
2-1/2"	11.9*	7.00	7.28	7.00	2.38	675E	34.30
3"	12.37*	7.00	8.07	7.00	2.38	1000E	33.00
4"	20.06**	10.00	9.45	10.00	3.75	2000E	81.50

* DECLUTCHABLE MANUAL OVERRIDE INCLUDED IN DIMENSIONS

** MOUNTING KIT INCLUDED IN DIMENSIONS

ELECTRIC FEATURES

- 120VAC, 220VAC, 24VAC, 12VDC and 24VDC
- NEMA 4, 4X and 7 housings
- Manual overrides
- Visual indicators
- Open/close or modulating service

FOR NEMA 7 ELECTRIC DIMENSIONS OR OTHER CONFIGURATIONS, CONTACT OUR SALES STAFF.

FOR MORE INFORMATION ON BI-TORQ ACTUATORS, REFER TO OUR INDIVIDUAL PNEUMATIC AND ELECTRIC CATALOGS, OR VISIT BITORQ.COM.

IS-3P SERIES 3-PC STAINLESS STEEL BALL VALVES

BILL OF MATERIALS

PART #	NAME	MATERIAL	QTY
1	ENDS	ASTM A351 GR CF8M	2
2	BODY SEAL	PTFE	1
3	BALL	316SS	1
4	BODY	ASTM A351 GR CF8M	1
5	SEAT	RTFE	2
6	WASHER	304SS	4
7	NUT	304SS	4
8	STEM SEAL	PTFE	1
9	O-RING	VITON	1
10	STEM PACKING	PTFE	1
11	BELLEVILLE WASHER	304SS	2
12	STEM NUT	304SS	1
13	STEM	316SS	1
14	BODY BOLT	304SS	4

2-1/2" AND LARGER MANUAL VALVES USE A BARSTOCK HANDLE

VALVE FEATURES

- Full port stainless steel valve
- 1/4" through 4" size range
- NPT, socket weld ends
- RTFE® seats/TFE seals
- Swing out design for easy maintenance
- ISO mounting pad

**NOTE: NOT RECOMMENDED
FOR USE IN OZONE SERVICE;
PLEASE CONSULT FACTORY FOR
RECOMMENDED VALVES**

PRESSURE RATING
1000 PSI CWP
TEMPERATURE RATING
+400° F Maximum
-4° F Minimum

**NOTE: MAXIMUM TEMPERATURE RATING FOR STANDARD ACTUATORS
IS 150° F (ELECTRIC) AND 180° (PNEUMATIC). SPECIAL SEALS OR HEAT
EXTENSIONS ARE AVAILABLE FOR HIGH TEMPERATURE SERVICE.**

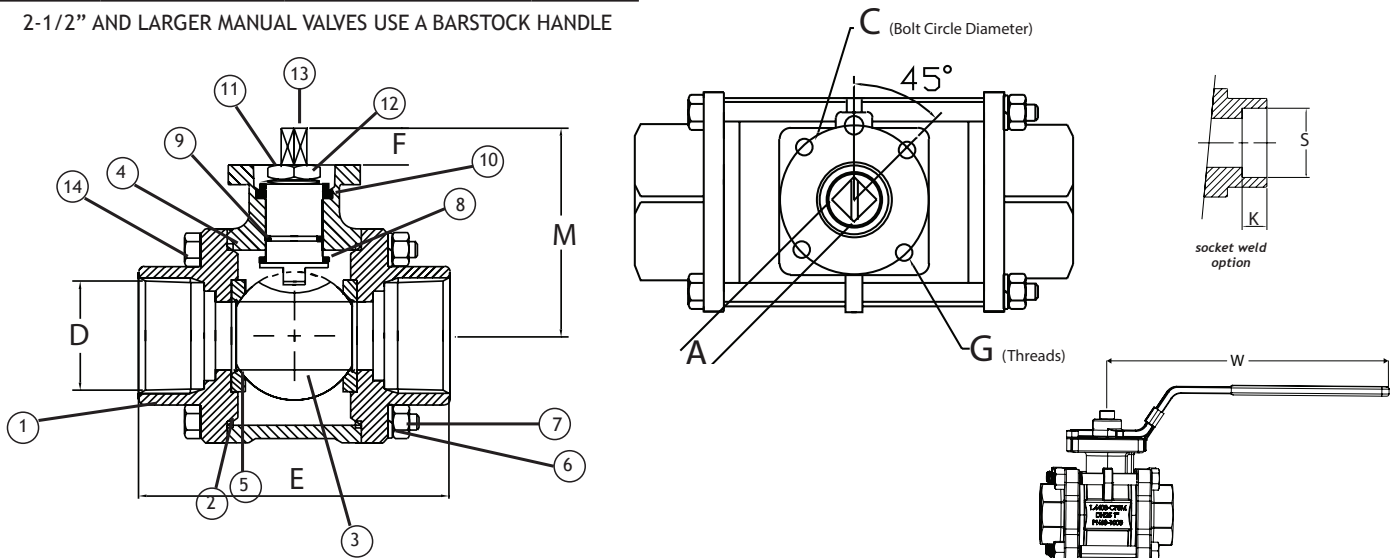

DIMENSIONAL DATA

SIZE	ISO 5211	A	C	D	E	F	G	K	M	S	W	CV	WT.
1/4"	F03-F04	0.35	1.42/1.65	0.45	2.56	0.27	0.22/0.28	0.40	1.96	0.56	5.25	4	1.27
3/8"	F03-F04	0.35	1.42/1.65	0.50	2.56	0.27	0.22/0.28	0.40	1.96	0.70	5.25	10	1.27
1/2"	F03-F04	0.35	1.42/1.65	0.59	2.95	0.27	0.22/0.28	0.50	1.96	0.87	5.25	24	1.45
3/4"	F03-F04	0.35	1.42/1.65	0.79	3.15	0.31	0.22/0.28	0.62	2.08	1.08	5.25	47	1.75
1"	F04-F05	0.43	1.65/1.97	0.98	3.54	0.43	0.28/0.35	0.69	2.52	1.35	7.50	81	3.10
1-1/4"	F04-F05	0.43	1.65/1.97	1.26	4.33	0.43	0.28/0.35	0.75	2.67	1.69	7.50	132	4.35
1-1/2"	F05-F07	0.55	1.97/2.76	1.50	4.72	0.55	0.28/0.35	0.88	3.23	1.93	8.25	202	6.65
2"	F05-F07	0.55	1.97/2.76	1.97	5.51	0.55	0.28/0.35	0.88	3.58	2.42	8.25	376	10.00
2-1/2"	F07-F10	0.67	2.76/4.02	2.50	7.28	0.67	0.28/0.35	0.88	4.57	3.04	12.00	642	21.30
3"	F07-F10	0.67	2.76/4.02	3.15	8.07	0.67	0.28/0.35	1.00	5.04	3.54	12.00	901	30.00
4"	F10-F12	0.87	4.02/4.92	3.82	9.45	0.87	0.35/0.50	1.26	6.30	4.54	N/A	1588	51.50

THE MANUAL VERSION OF THIS MODEL STARTS WITH AN "M"

ALL VALVES ARE 100% ELECTRONICALLY TESTED AT 80 PSI IN BOTH THE OPEN AND CLOSED POSITIONS

FS-3P (SS) & FW-3P (CS) SERIES 3-PC FIRE SAFE BALL VALVES

PNEUMATIC ACTUATORS

PNEUMATIC FEATURES

- Rack and pinion design
- NAMUR accessory mounting
- Spring return and double acting
- Visual indicators
- Optional SS construction

ALL STANDARD ACTUATORS SIZED FOR 80 PSI AIR SUPPLY; PLEASE CONSULT FACTORY FOR OTHER COMBINATIONS

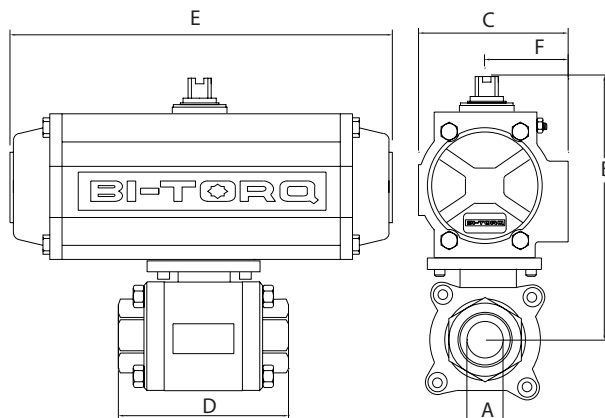

FOR A LIST OF AUTOMATION ACCESSORIES WE CAN OFFER, PLEASE REFER TO PAGE 31 OR VISIT BITORQ.COM

DOUBLE ACTING ASSEMBLY DIMENSIONS							
A	B	C	D	E	F	ACT.	WT.
1/4"	7.21*	2.79	2.55	5.49	1.61	52DA	4.67
3/8"	7.21*	2.79	2.55	5.49	1.61	52DA	4.67
1/2"	7.21*	2.79	2.95	5.49	1.61	52DA	4.67
3/4"	5.29	2.79	3.14	5.49	1.61	52DA	5.08
1"	6.05	3.17	3.54	6.38	1.77	63DA	8.11
1-1/4"	6.2	3.17	4.33	6.38	1.77	63DA	10.62
1-1/2"	6.64	3.17	4.72	6.38	1.77	63DA	13.39
2"	7.64	3.72	5.51	8.15	2.07	75DA	21.61

* MOUNTING KIT INCLUDED IN DIMENSIONS

SPRING RETURN ASSEMBLY DIMENSIONS							
A	B	C	D	E	F	ACT.	WT.
1/4"	7.65*	3.17	2.55	6.38	1.77	63SR	6.39
3/8"	7.65*	3.17	2.55	6.38	1.77	63SR	6.39
1/2"	7.65*	3.17	2.95	6.38	1.77	63SR	6.39
3/4"	5.73	3.17	3.14	6.38	1.77	63SR	7.52
1"	6.7	3.72	3.54	8.15	2.07	75SR	11.79
1-1/4"	7.3	4.17	4.33	9.35	2.30	85SR	16.73
1-1/2"	8.25	4.85	4.72	10.69	2.68	100SR	24.53
2"	9.78	5.39	5.51	12.91	2.87	115SR	40.02

* MOUNTING KIT INCLUDED IN DIMENSIONS

ELECTRIC ACTUATORS

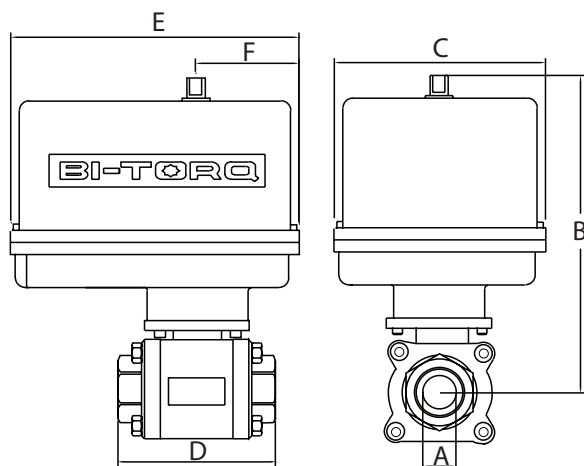

NEMA 4 ELECTRIC ASSEMBLY DIMENSIONS							
A	B	C	D	E	F	ACT.	WT.
1/4"	8.57**	4.00	2.55	5.63	2.31	100E	7.42
3/8"	8.57**	4.00	2.55	5.63	2.31	100E	7.42
1/2"	8.57**	4.00	2.95	5.63	2.31	100E	7.42
3/4"	7.65	4.25	3.14	6.88	2.43	200E	10.55
1"	7.97	4.25	3.54	6.88	2.43	200E	11.85
1-1/4"	8.12	4.25	4.33	6.88	2.43	300E	14.36
1-1/2"	8.56	4.25	4.72	6.88	2.43	300E	17.13
2"	11.03*	7.00	5.51	7.00	2.38	675E	29.10

* DECLUTCHABLE MANUAL OVERRIDE INCLUDED IN DIMENSIONS

** MOUNTING KIT INCLUDED IN DIMENSIONS

ELECTRIC FEATURES

- 120VAC, 220VAC, 24VAC, 12VDC and 24VDC
- NEMA 4, 4X and 7 housings
- Manual overrides
- Visual indicators
- Open/close or modulating service

FOR NEMA 7 ELECTRIC DIMENSIONS OR OTHER CONFIGURATIONS, CONTACT OUR SALES STAFF.

FOR MORE INFORMATION ON BI-TORQ ACTUATORS, REFER TO OUR INDIVIDUAL PNEUMATIC AND ELECTRIC CATALOGS, OR VISIT BITORQ.COM.

FS-3P (SS) & FW-3P (CS) SERIES 3-PC FIRE SAFE BALL VALVES

BILL OF MATERIALS

PART #	NAME	MATERIAL	QTY
1	BODY	WCB or CF8M	1
2	END CAP	WCB OR CF8M	2
3	BALL	CF8M	1
4	SEAT	RTFE	2
5	BODY SEAL	GRAPHITE	2
6	THRUST WASHER	GRAPHITE	1
7	STEM PACKING	GRAPHITE	1
8	GLAND	304SS	1
9	BELLEVILLE SPRING WASHER	301SS	2
10	STEM	316SS	1
11	NUT	304 SS	1
12	SPRING WASHER	304 SS	1
13	NUT	304 SS	1
14	BOLT	304 SS	4*
15	HANDLE	304 SS	1
16	HANDLE SLEEVE	VINYL	1
17	SADDLE WASHER	304 SS	1
18	O-RING	VITON	1
19	STOP PIN	304 SS	1
20	ANTI-STATIC DEVICE	304 SS	1

* QTY 8 on 2" valve size

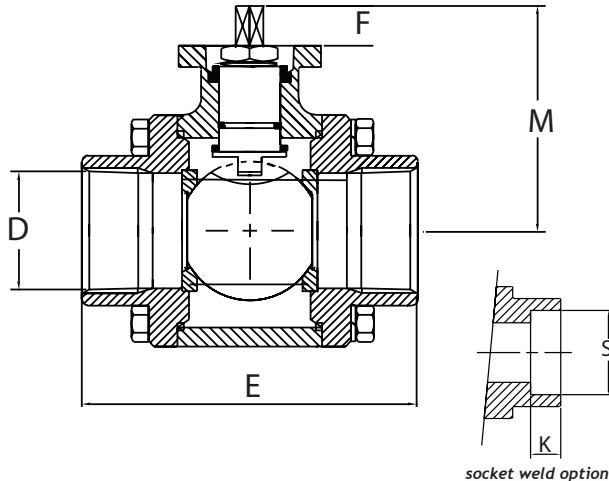

VALVE FEATURES

- Full port 3-pc SS(FS) or WCB(FW) valve
- 1/4" through 2" size range
- NPT or socket weld ends
- RTFE® seats with graphoil seals
- Enclosed body bolts for extreme service
- ISO mounting pad
- API 607 4th editon fire safe

PRESSURE RATING
2000 PSI CWP
TEMPERATURE RATING
+350° F Maximum
-4° F Minimum

NOTE: MAXIMUM TEMPERATURE RATING FOR STANDARD ACTUATORS IS 150° F (ELECTRIC) AND 180° (PNEUMATIC). SPECIAL SEALS OR HEAT EXTENSIONS ARE AVAILABLE FOR HIGH TEMPERATURE SERVICE.

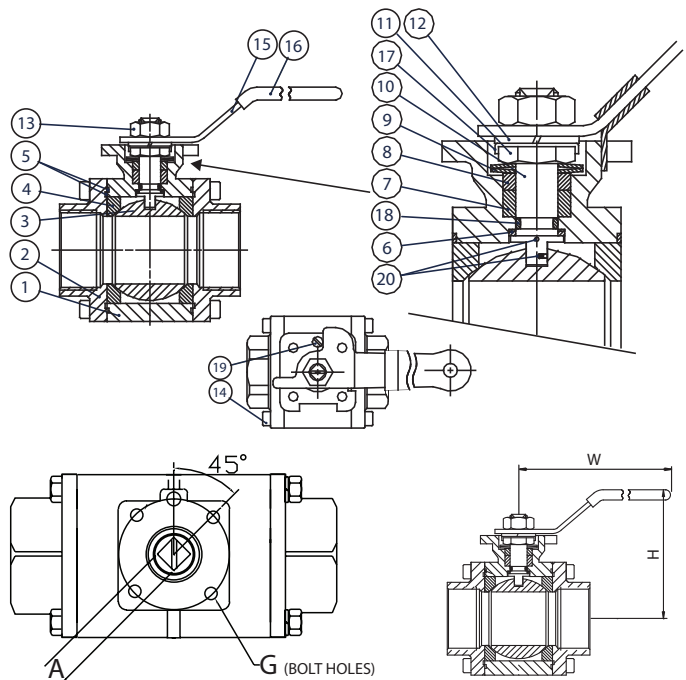

DIMENSIONAL DATA

SIZE	ISO 5211	A	D	E	F	G	H	K	M	S	W	CV	WT.
1/4"	F04	0.35	0.45	2.56	0.27	0.28	2.75	0.39	1.96	0.56	5.51	6.30	2.42
3/8"	F04	0.35	0.50	2.56	0.27	0.28	2.75	0.39	1.96	0.70	5.51	6.20	2.42
1/2"	F04	0.35	0.59	2.95	0.27	0.28	2.75	0.51	1.96	0.87	5.51	20.90	2.42
3/4"	F04-F05	0.43	0.79	3.15	0.31	0.28/0.35	3.54	0.59	2.2	1.08	7.08	49.40	3.55
1"	F04-F05	0.43	0.98	3.54	0.43	0.28/0.35	3.93	0.59	2.52	1.35	7.08	81.00	4.85
1-1/4"	F07	0.55	1.26	4.33	0.43	0.45	4.40	0.59	2.79	1.69	8.46	127.9	7.36
1-1/2"	F07	0.55	1.50	4.72	0.55	0.45	4.52	0.63	3.23	1.93	8.46	191.50	10.13
2"	F07	0.55	1.97	5.51	0.55	0.45	5.23	0.67	3.03	2.42	8.46	376	16.10

ALL VALVES ARE 100% ELECTRONICALLY TESTED AT 80 PSI IN BOTH THE OPEN AND CLOSED POSITIONS

IS-2PF SERIES STAINLESS STEEL FLANGED BALL VALVES

PNEUMATIC ACTUATORS

PNEUMATIC FEATURES

- Rack and pinion design
- NAMUR accessory mounting
- Spring return and double acting
- Visual indicators
- Optional SS construction

ALL STANDARD ACTUATORS SIZED FOR 80 PSI AIR SUPPLY; PLEASE CONSULT FACTORY FOR OTHER COMBINATIONS

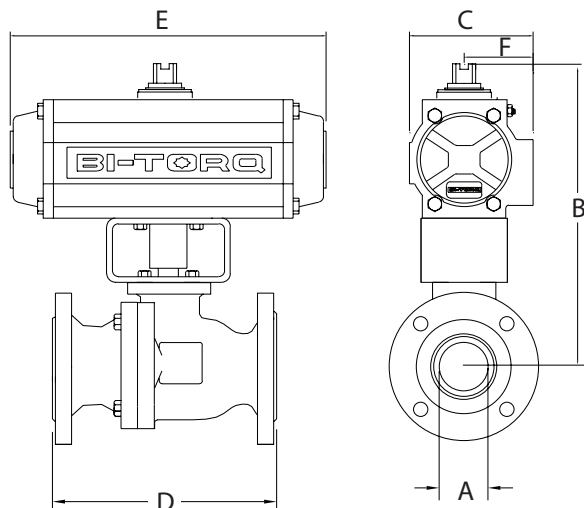

FOR A LIST OF AUTOMATION ACCESSORIES WE CAN OFFER, PLEASE REFER TO PAGE 31 OR VISIT BITORQ.COM

DOUBLE ACTING ASSEMBLY DIMENSIONS							
A	B	C	D	E	F	ACT.	WT.
1/2"	7.04	2.79	4.25	5.49	1.61	52DA	7.05
3/4"	7.15	2.79	4.63	5.49	1.61	52DA	10.30
1"	7.57	2.79	5.00	5.49	1.61	52DA	12.30
1-1/4"	8.31	3.17	5.50	6.38	1.77	63DA	17.30
1-1/2"	8.58	3.17	6.50	6.38	1.77	63DA	21.50
2"	9.56	3.17	7.00	8.15	2.07	75DA	28.60
2-1/2"	10.58	4.17	7.50	9.35	2.30	85DA	52.15
3"	12.29	4.17	8.00	9.35	2.30	85DA	56.50
4"	14.59	5.39	9.00	12.91	2.87	115DA	95.60

SPRING RETURN ASSEMBLY DIMENSIONS							
A	B	C	D	E	F	ACT.	WT.
1/2"	7.48	3.17	4.25	6.38	1.77	63SR	9.95
3/4"	7.59	3.17	4.63	6.38	1.77	63SR	11.95
1"	8.66	3.72	5.00	8.15	2.07	75SR	17.08
1-1/4"	9.41	4.17	5.50	9.35	2.30	85SR	24.50
1-1/2"	9.68	4.17	6.50	9.35	2.30	85SR	27.25
2"	10.52	4.84	7.00	10.69	2.68	100SR	36.45
2-1/2"	12.27	5.39	7.50	12.91	2.87	115SR	63.35
3"	14.45	5.83	8.00	14.41	3.15	125SR	80.50
4"	16.58	7.35	9.00	16.93	3.94	161SR	132.80

ELECTRIC ACTUATORS

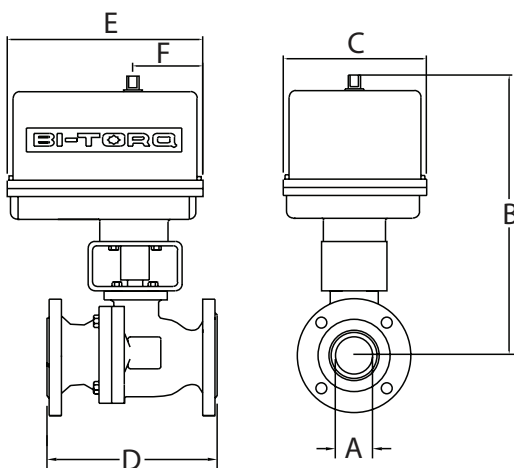

NEMA 4 ELECTRIC ASSEMBLY DIMENSIONS							
A	B	C	D	E	F	ACT.	WT.
1/2"	7.90	4.00	4.25	5.63	2.30	100E	11.00
3/4"	8.51	4.00	4.63	5.63	2.30	100E	13.00
1"	9.93	4.25	5.00	6.88	2.43	200E	17.00
1-1/4"	10.23	4.25	5.50	6.88	2.43	300E	23.00
1-1/2"	10.50	4.25	6.50	6.88	2.43	300E	26.00
2"	12.95*	7.00	7.00	7.00	2.38	675E	37.00
2-1/2"	13.52*	7.00	7.50	7.00	2.38	675E	55.00
3"	15.05*	7.00	8.00	7.00	2.38	1500E	65.00
4"	15.84*	7.00	9.00	7.00	2.38	1500E	94.00

* DECLUTCHABLE MANUAL OVERRIDE INCLUDED IN DIMENSIONS

ELECTRIC FEATURES

- 120VAC, 220VAC, 24VAC, 12VDC and 24VDC
- NEMA 4, 4X and 7 housings
- Manual overrides
- Visual indicators
- Open/close or modulating service

FOR NEMA 7 ELECTRIC DIMENSIONS OR OTHER CONFIGURATIONS, CONTACT OUR SALES STAFF.

FOR MORE INFORMATION ON BI-TORQ ACTUATORS, REFER TO OUR INDIVIDUAL PNEUMATIC AND ELECTRIC CATALOGS, OR VISIT BITORQ.COM.

IS-2PF SERIES STAINLESS STEEL FLANGED BALL VALVES

BILL OF MATERIALS

PART #	NAME	MATERIAL	QTY
1	BODY	ASTM A351 GR CF8M	1
2	ENDS	ASTM A351 GR CF8M	2
3	BALL	ASTM A351 GR CF8M	1
4	SEAT	RTFE	2
5	BODY SEAL	RTFE	2
6	STEM SEAL	RTFE	1
7	STEM PACKING	RTFE	1
8	THRUST WASHER	50% PTFE + 50% SS POWDER	1
9	O-RING	VITON	1
10	BELLEVILLE WASHER	304SS	2
11	LOCK WASHER	304SS	1
12	STEM NUT	304SS	1
13	HANDLE*	304SS	1

* 1-1/2" AND LARGER MANUAL VALVES USE A BARSTOCK HANDLE

VALVE FEATURES

- Full port stainless steel ball valve
- 1/2" through 4"
- Class 150# flanged ends
- Designed to ANSI B16.34 standards
- RTFE® seats
- Optional fire safe design (w/graphoil seals)
- ISO mounting pad
- Vacuum to 29 inHg

PRESSURE RATING
ANSI Class 150
TEMPERATURE RATING
+400° F Maximum
-20° F Minimum

NOTE: MAXIMUM TEMPERATURE RATING FOR STANDARD ACTUATORS IS 150° F (ELECTRIC) AND 180° (PNEUMATIC). SPECIAL SEALS OR HEAT EXTENSIONS ARE AVAILABLE FOR HIGH TEMPERATURE SERVICE.

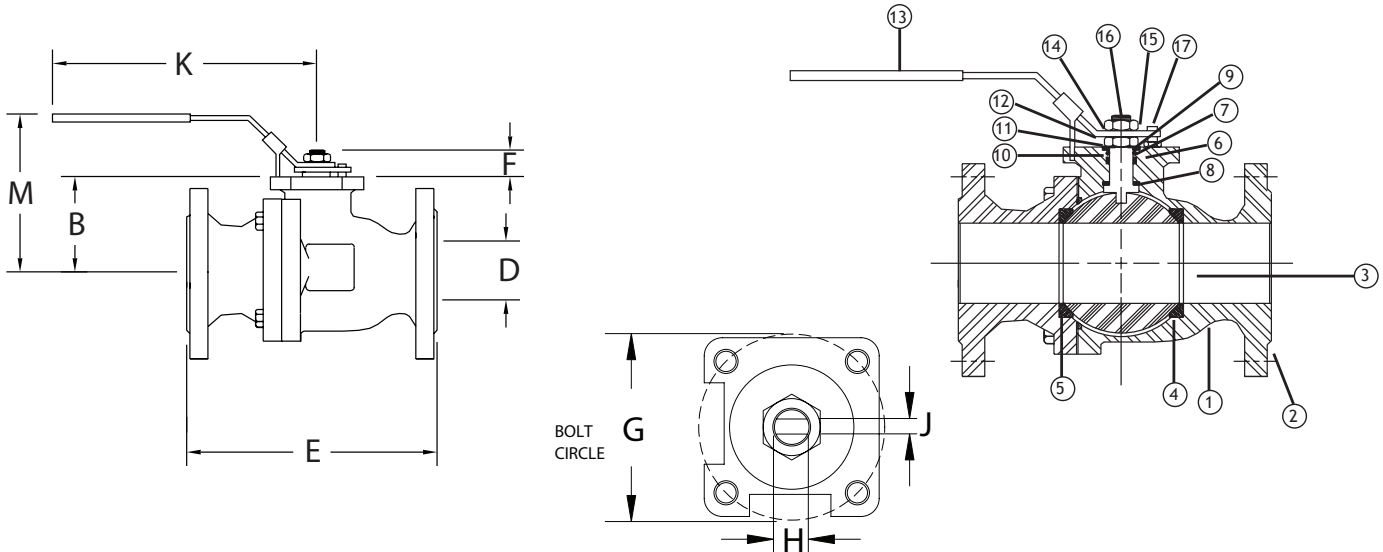

DIMENSIONAL DATA

SIZE	ISO 5211	B	D	E	F	G	H	J	K	M	CV	WT.
1/2"	F04	1.52	0.59	4.25	0.69	1.42	0.47	0.25	5.91	3.54	30	4
3/4"	F04	1.63	0.79	4.63	0.72	1.42	0.47	0.25	5.91	3.88	50	6
1"	F05	2.05	0.98	5.00	0.85	1.97	0.51	0.31	7.09	4.25	100	8
1-1/4"	F05	2.35	1.26	5.50	0.81	1.97	0.51	0.31	7.09	4.62	180	12
1-1/2"	F07	2.62	1.57	6.50	1.14	2.76	0.53	0.37	8.27	5.00	250	16
2"	F07	2.95	1.97	7.00	1.16	2.76	0.53	0.37	8.27	6.00	480	21
2-1/2"	F07	3.52	2.56	7.50	1.52	2.76	1.14	0.67	10.24	7.00	750	38
3"	F10	4.23	3.15	8.00	1.85	4.02	1.14	0.67	10.24	7.50	1300	46
4"	F10	4.84	3.94	9.00	1.85	4.02	1.14	0.67	12.20	9.00	2400	73

THE MANUAL VERSION OF THIS MODEL STARTS WITH AN "M"

ALL VALVES ARE 100% ELECTRONICALLY TESTED AT 80 PSI IN BOTH THE OPEN AND CLOSED POSITIONS

IS-3TC SERIES SANITARY CLAMP END BALL VALVES

PNEUMATIC ACTUATORS

PNEUMATIC FEATURES

- Rack and pinion design
- NAMUR accessory mounting
- Spring return and double acting
- Visual indicators
- Optional SS construction

ALL STANDARD ACTUATORS SIZED FOR 80 PSI AIR SUPPLY; PLEASE CONSULT FACTORY FOR OTHER COMBINATIONS

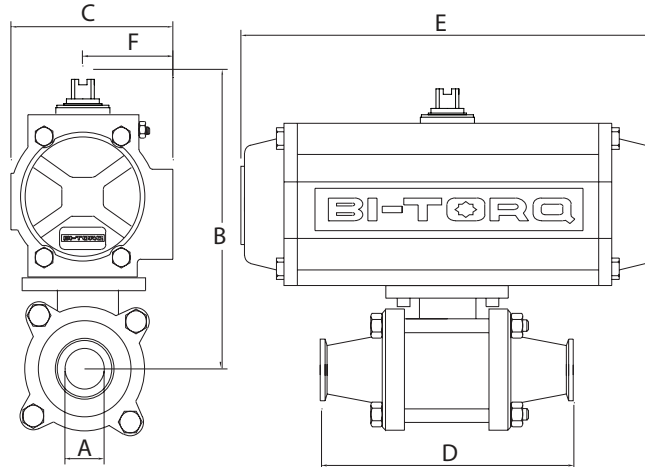

FOR A LIST OF AUTOMATION ACCESSORIES WE CAN OFFER, PLEASE REFER TO PAGE 31 OR VISIT BITORQ.COM

DOUBLE ACTING ASSEMBLY DIMENSIONS							
A	B	C	D	E	F	ACT.	WT.
1/2"	4.25	1.78	3.50	4.65	0.89	32DA	2.65
3/4"	5.35	2.79	3.98	5.49	1.61	52DA	4.30
1"	5.94	3.17	4.49	6.38	1.77	63DA	5.25
1-1/2"	7.27	3.72	5.51	8.15	2.07	75DA	11.30
2"	7.58	3.72	6.14	8.15	2.07	75DA	14.6
2-1/2"	8.80	4.17	7.76	9.35	2.30	85DA	29.8
3"	9.70	4.85	9.02	10.69	2.68	100DA	46.35
4"	11.71	5.39	9.57	12.91	2.87	115DA	66.30

SPRING RETURN ASSEMBLY DIMENSIONS							
A	B	C	D	E	F	ACT.	WT.
1/2"	5.21	2.79	3.50	5.49	1.61	52SR	4.15
3/4"	5.79	3.17	3.98	6.38	1.77	63SR	5.95
1"	6.59	3.72	4.49	8.15	2.07	75SR	6.85
1-1/2"	8.23	4.85	5.51	10.69	2.68	100SR	20.15
2"	8.54	4.85	6.14	10.69	2.68	100SR	23.45
2-1/2"	10.49	5.39	7.76	12.91	2.87	115SR	46.65
3"	11.35	5.83	9.02	14.41	3.15	125SR	65.70
4"	13.70	8.82	9.57	16.93	3.94	161SR	103.5

ELECTRIC ACTUATORS

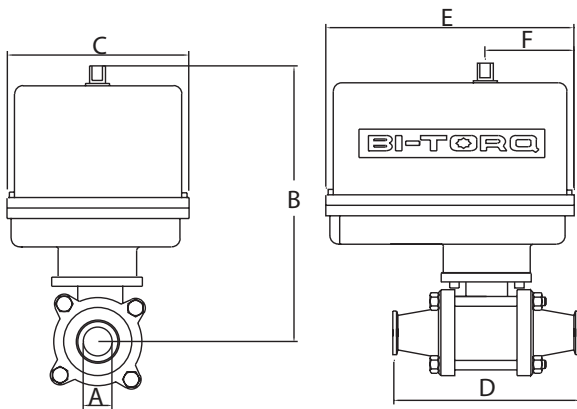

NEMA 4 ELECTRIC ASSEMBLY DIMENSIONS							
A	B	C	D	E	F	ACT.	WT.
1/2"	6.57	4.00	3.50	5.63	2.30	100E	6.40
3/4"	6.71	4.00	3.98	5.63	2.30	100E	7.00
1"	7.86	4.25	4.49	6.88	2.43	200E	9.90
1-1/2"	10.66*	7.00	5.51	7.00	2.38	400E	18.7
2"	10.97*	7.00	6.14	7.00	2.38	675E	22.00
2-1/2"	11.74*	7.00	7.76	7.00	2.38	1000E	37.30
3"	12.13*	7.00	9.02	7.00	2.38	1500E	48.20
4"	20.59*	10.00	9.57	10.00	3.75	2000E	80.70

* DECLUTCHABLE MANUAL OVERRIDE INCLUDED IN DIMENSIONS

ELECTRIC FEATURES

- 120VAC, 220VAC, 24VAC, 12VDC and 24VDC
- NEMA 4, 4X and 7 housings
- Manual overrides
- Visual indicators
- Open/close or modulating service

FOR NEMA 7 ELECTRIC DIMENSIONS OR OTHER CONFIGURATIONS, CONTACT OUR SALES STAFF.

FOR MORE INFORMATION ON BI-TORQ ACTUATORS, REFER TO OUR INDIVIDUAL PNEUMATIC AND ELECTRIC CATALOGS, OR VISIT BITORQ.COM.

IS-3TC SERIES SANITARY CLAMP END BALL VALVES

BILL OF MATERIALS

PART #	NAME	MATERIAL	QTY
1	END CAP	ASTM A351/GR CF8M	2
2	BODY SEAL	TFE	2
3	BALL	ASTM A351/316SS	1
4	BODY	ASTM A351/316SS	1
5	BALL SEAT	TFE	2
6	SPRING WASHER	304SS	1
7	GLAND NUT	304SS	1
8	STEM SEAL	TFE	1
9	O-RING	VITON	1
10	STEM PACKING	TFE	1
11	FOLLOWER	304SS	1
12	BELLEVILLE SPRING WASHERS	301SS	4
13	STEM NUT	304SS	1
14	STEM	316SS	1
15	BODY BOLT	304SS	4
16	HANDLE	304SS	1

VALVE FEATURES

- Full port sanitary valves
- 1/2" through 4"
- 240 grit bore polish
- Cavity filled TFE® seats to reduce the threat of media entrapment
- Swing out design for easy maintenance
- Polished clamp end to meet BS 4825.3

PRESSURE RATING
1000 PSI CWP (1/2" - 2")
800 PSI CWP (2-1/2" - 3")
600 PSI CWP (4")
TEMPERATURE RATING
+450° F Maximum
-4° F Minimum

NOTE: MAXIMUM TEMPERATURE RATING FOR STANDARD ACTUATORS IS 150° F (ELECTRIC) AND 180° (PNEUMATIC). SPECIAL SEALS OR HEAT EXTENSIONS ARE AVAILABLE FOR HIGH TEMPERATURE SERVICE.

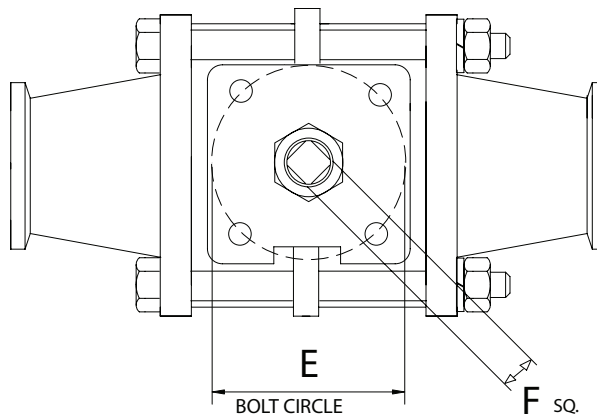
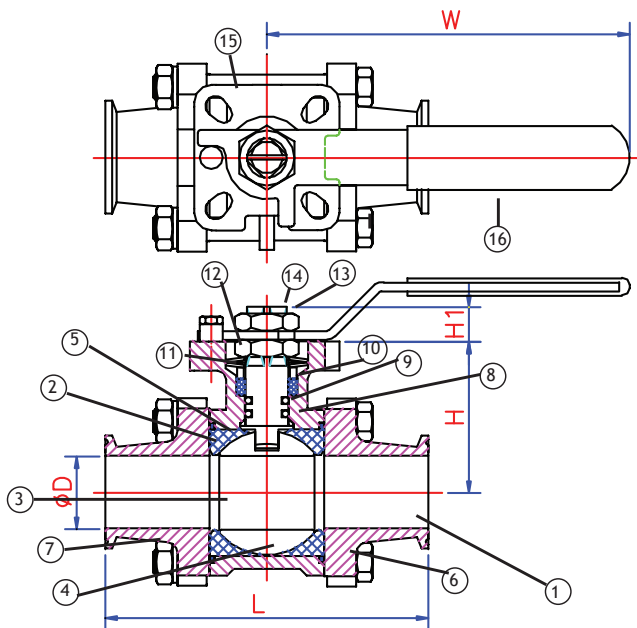

DIMENSIONAL DATA

SIZE	ISO 5211	D	E	F	H	H1	L	W	CV	WT.
1/2"	F03-F04	0.37	1.42/1.65	0.35	1.69	0.354	3.50	4.57	14	1.40
3/4"	F03-F04	0.63	1.42/1.65	0.35	1.83	0.354	3.98	4.57	45	2.0
1"	F04-F05	0.87	1.65/1.97	0.43	1.98	0.443	4.49	6.14	81	2.90
1-1/2"	F05-F07	1.36	1.97/2.76	0.55	2.66	0.551	5.51	7.13	215	5.70
2"	F05-F07	1.87	1.97/2.76	0.55	2.97	0.551	6.14	7.13	410	9.00
2-1/2"	F07-F10	2.37	2.76/4.02	0.67	3.74	0.669	7.76	10.24	618	19.3
3"	F07-F10	2.87	2.76/4.02	0.67	4.13	0.669	9.02	10.24	940	31.2
4"	F10-F12	3.83	4.02/4.92	0.87	4.96	0.869	9.57	13.19	1840	43.7

THE MANUAL VERSION OF THIS MODEL STARTS WITH AN "M"

ALL VALVES ARE 100% ELECTRONICALLY TESTED AT 80 PSI IN BOTH THE OPEN AND CLOSED POSITIONS

IS-3WTC SERIES SANITARY CLAMP END 3-WAY BALL VALVES

PNEUMATIC ACTUATORS

PNEUMATIC FEATURES

- Rack and pinion design
- NAMUR accessory mounting
- Spring return and double acting
- Visual indicators
- Optional SS construction

ALL STANDARD ACTUATORS SIZED FOR 80 PSI AIR SUPPLY; PLEASE CONSULT FACTORY FOR OTHER COMBINATIONS

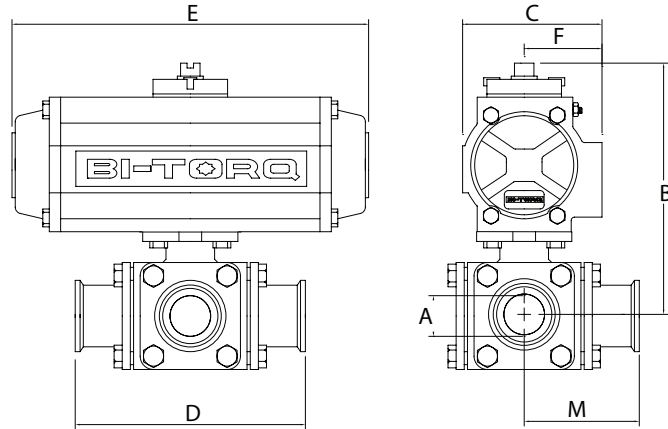

FOR A LIST OF AUTOMATION ACCESSORIES WE CAN OFFER, PLEASE REFER TO PAGE 31 OR VISIT BITORQ.COM

DOUBLE ACTING ASSEMBLY DIMENSIONS								
D	B	C	A	E	F	M	ACT.	WT.
1/2"	4.92	2.79	4.65	5.49	1.61	2.32	52DA	5.86
3/4"	5.06	2.79	5.00	5.49	1.61	2.50	52DA	6.61
1"	5.85	3.17	6.00	6.38	1.77	3.00	63DA	10.08
1-1/2"	6.89	3.72	6.89	8.15	2.07	3.45	75DA	18.40
2"	7.74	4.17	7.48	9.35	2.30	3.74	85DA	30.45

SPRING RETURN ASSEMBLY DIMENSIONS							
D	B	C	AE	F	M	ACT.	WT.
1/2"	4.92	2.79	5.49	1.61	2.32	52SR	6.23
3/4"	8.50*	3.17	6.38	1.77	2.50	63SR	11.33
1"	6.50	3.72	8.15	2.07	3.00	75SR	13.76
1-1/2"	9.03	5.39	12.91	2.87	3.45	115SR	36.81
2"	9.94	5.39	12.91	2.87	3.74	115SR	46.98

* MOUNTING KIT INCLUDED IN DIMENSIONS

ELECTRIC ACTUATORS

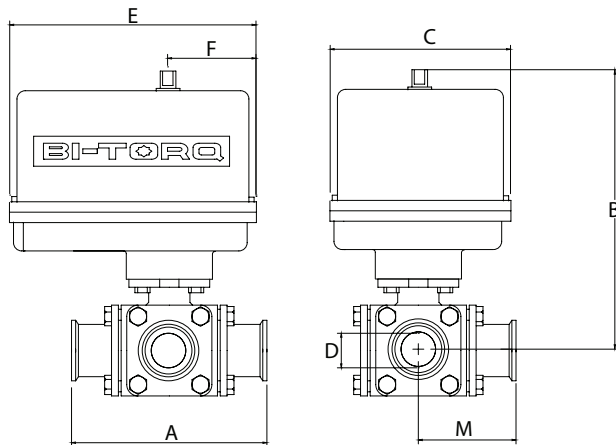

NEMA 4 ELECTRIC ASSEMBLY DIMENSIONS									
D	B	C	A	E	F	M	ACT.	WT.	
1/2"	6.28	4.00	4.65	5.63	2.30	2.32	100E	8.61	
3/4"	6.42	4.00	5.00	5.63	2.30	2.50	100E	11.36	
1"	7.77	4.25	6.00	6.88	2.43	3.00	200E	13.82	
1-1/2"	10.28	7.00	6.89	7.00	2.38	3.45	400E**	25.89	
2"	10.68	7.00	7.48	7.00	2.38	3.74	1000E**	36.06	

* DECLUTCHABLE MANUAL OVERRIDE INCLUDED IN DIMENSIONS

ELECTRIC FEATURES

- 120VAC, 220VAC, 24VAC, 12VDC and 24VDC
- NEMA 4, 4X and 7 housings
- Manual overrides
- Visual indicators
- Open/close or modulating service

FOR NEMA 7 ELECTRIC DIMENSIONS OR OTHER CONFIGURATIONS, CONTACT OUR SALES STAFF.

FOR MORE INFORMATION ON BI-TORQ ACTUATORS, REFER TO OUR INDIVIDUAL PNEUMATIC AND ELECTRIC CATALOGS, OR VISIT BITORQ.COM.

IS-3WTC SERIES SANITARY CLAMP END 3-WAY BALL VALVES

BILL OF MATERIALS

PART #	NAME	MATERIAL	QTY
1	BODY	CF8M	1
2	END CAP	CF8M	2
3	BALL	CF8M	1
4	SEAT	PTFE	2
5	GASKET	PTFE	2
6	THRUST WASHER	PTFE	1
7	O-RING	VITON	1
8	STEM PACKING	PTFE	1
9	PACKING RING	316 SS	1
10	BEVEL WASHER	301 SS	2
11	STEM	316 SS	1

VALVE FEATURES

- 3-Way sanitary valves
- 1/2" through 2" size range
- 240 grit bore polish
- Cavity filled TFE® seats to reduce the threat of media entrapment
- Block body and bolted end piece design for easy maintenance
- Polished clamp end to meet BS 4825.3

NOTE: not suitable for vacuum service

PRESSURE RATING
1000 PSI CWP (valve body)
200 PSI operating

TEMPERATURE RATING
+350°F Maximum
-4°F Minimum

See page 31 for possible pressure limitations due to flow patterns in certain applications with our floating ball valve design.

NOTE: MAXIMUM TEMPERATURE RATING FOR STANDARD ACTUATORS IS 150°F (ELECTRIC) AND 180°F (PNEUMATIC). SPECIAL SEALS OR HEAT EXTENSIONS ARE AVAILABLE FOR HIGH TEMPERATURE SERVICE.

SEE PAGE 31 FOR AVAILABLE FLOW PATTERNS

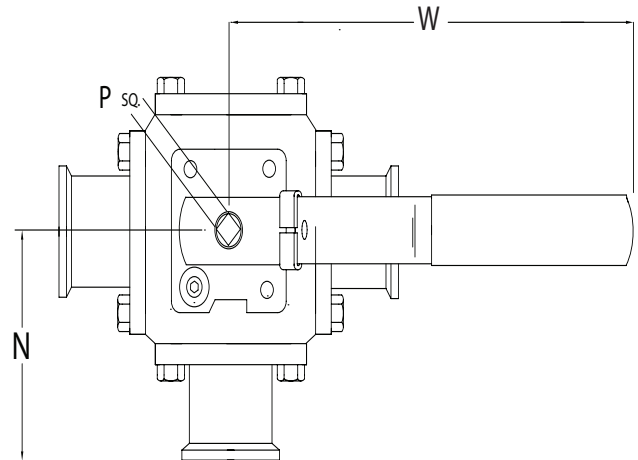
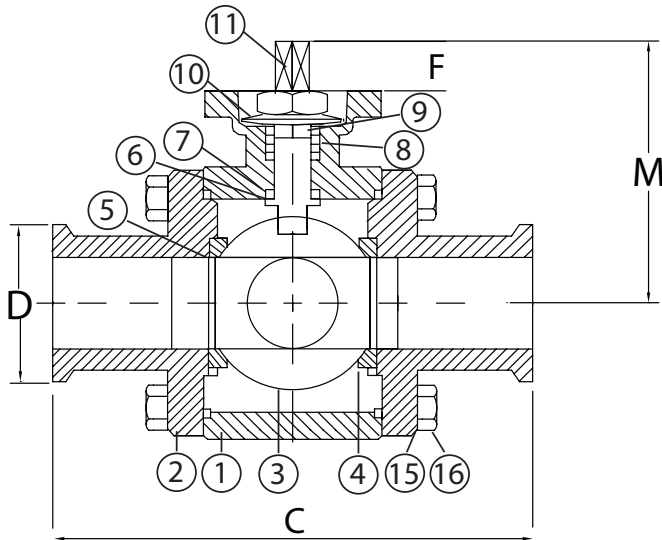

DIMENSIONAL DATA

SIZE	ISO 5211	C	D	F	M	N	P	W	WT.
1/2"	F03-F04	4.65	0.99	0.35	1.75	2.32	0.35	4.76	3.61
3/4"	F03-F04	5.00	0.99	0.35	1.89	2.50	0.35	4.76	4.36
1"	F04-F05	6.00	1.99	0.43	2.32	3.00	0.43	5.39	6.82
1-1/2"	F05-F07	6.89	1.99	0.55	2.83	3.44	0.55	7.17	12.89
2"	F05-F07	7.48	2.52	0.55	3.23	3.74	0.55	7.17	23.06

THE MANUAL VERSION OF THIS MODEL STARTS WITH AN "M"

ALL VALVES ARE 100% ELECTRONICALLY TESTED AT 80 PSI IN BOTH THE OPEN AND CLOSED POSITIONS

IS-3W SERIES 3-WAY BALL VALVES

PNEUMATIC ACTUATORS

PNEUMATIC FEATURES

- Rack and pinion design
- NAMUR accessory mounting
- Spring return and double acting
- Visual indicators
- Optional SS construction

ALL STANDARD ACTUATORS SIZED FOR 80 PSI AIR SUPPLY; PLEASE CONSULT FACTORY FOR OTHER COMBINATIONS

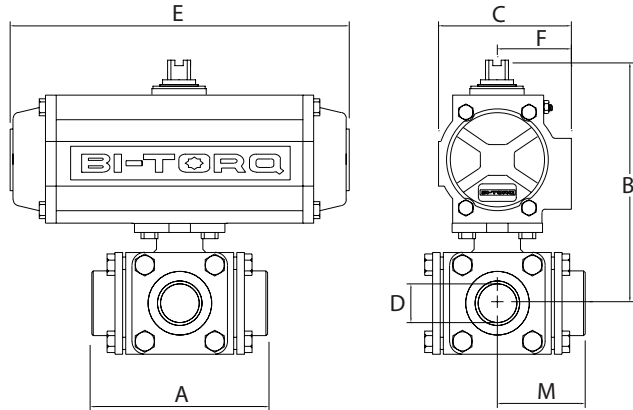

FOR A LIST OF AUTOMATION ACCESSORIES WE CAN OFFER, PLEASE REFER TO PAGE 31 OR VISIT BITORQ.COM

DOUBLE ACTING ASSEMBLY DIMENSIONS								
D	A	B	C	E	F	M	ACT.	WT.
1/2"	3.78	5.40	2.79	5.49	1.61	1.89	52DA	6.2
3/4"	4.21	5.81	2.79	5.49	1.61	2.11	52DA	7.85
1"	4.96	6.04	2.79	5.49	1.61	2.48	52DA	11.85
1-1/4"	5.24	7.07	3.17	6.38	1.77	2.62	63DA	14.2
1-1/2"	5.94	8.09	3.72	8.15	2.07	2.97	75DA	24.05
2"	6.54	8.78	3.72	8.15	2.07	3.27	75DA	28.85

SPRING RETURN ASSEMBLY DIMENSIONS								
D	A	B	C	E	F	M	ACT.	WT.
1/2"	3.78	5.40	2.79	5.49	1.61	1.89	52SR	6.55
3/4"	4.21	6.25	3.17	6.38	1.77	2.11	63SR	9.6
1"	4.96	7.13	3.72	8.15	2.07	2.48	75SR	15.9
1-1/4"	5.24	7.72	3.72	8.15	2.07	2.62	75SR	18.95
1-1/2"	5.94	9.05	4.85	10.69	2.68	2.97	100SR	32.9
2"	6.54	10.92	5.39	12.91	2.87	3.27	115SR	45.6

ELECTRIC ACTUATORS

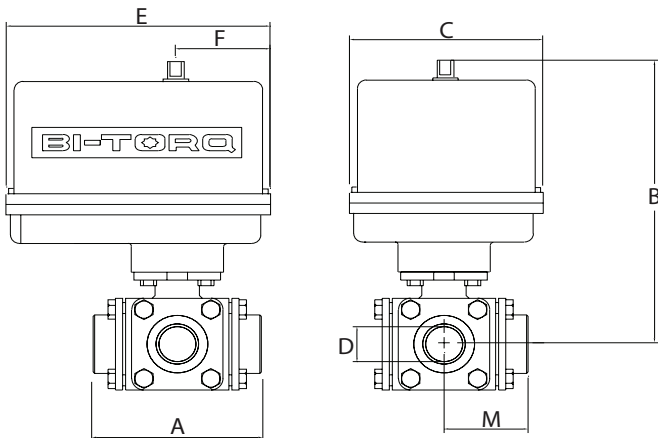

NEMA 4 ELECTRIC ASSEMBLY DIMENSIONS								
D	A	B	C	E	F	M	ACT.	WT.
1/2"	3.78	6.76	4.00	5.63	2.30	1.89	100E	8.90
3/4"	4.21	8.17	4.25	6.88	2.43	2.11	200E	12.65
1"	4.96	8.40	4.25	6.88	2.43	2.48	200E	15.85
1-1/4"	5.24	8.99	4.25	6.88	2.43	2.62	300E	18.9
1-1/2"	5.94*	11.48	7.00	7.00	2.38	2.97	400E	31.45
2"	6.54*	12.17	7.00	7.00	2.38	3.27	675E	34.25

* DECLUTCHABLE MANUAL OVERRIDE INCLUDED IN DIMENSIONS

ELECTRIC FEATURES

- 120VAC, 220VAC, 24VAC, 12VDC and 24VDC
- NEMA 4, 4X and 7 housings
- Manual overrides
- Visual indicators
- Open/close or modulating service

FOR NEMA 7 ELECTRIC DIMENSIONS OR OTHER CONFIGURATIONS, CONTACT OUR SALES STAFF.

FOR MORE INFORMATION ON BI-TORQ ACTUATORS, REFER TO OUR INDIVIDUAL PNEUMATIC AND ELECTRIC CATALOGS, OR VISIT BITORQ.COM.

IS-3W SERIES 3-WAY BALL VALVES

BILL OF MATERIALS

PART #	NAME	MATERIAL	QTY
1	BODY	316SS	1
2	END CONNECTION	316SS	3
3	BODY SEAL	PTFE	4
4	BALL	316SS	1
5	SEATS	RTFE	4
6	STEM	316SS	1
7	THRUST WASHER	PTFE	1
8	STEM PACKING	PTFE	1
9	GLAND	304SS	1
10	BELLEVILLE WASHER	304SS	2
11	PACKING NUT	304SS	1
12	SPRING WASHER	304SS	1
13	BODY BOLTS	304SS	1
14	BLANK CAP	316SS	1

See page 31 for possible pressure limitations due to flow patterns in certain applications with our floating ball valve design.

VALVE FEATURES

- 3-Way full port stainless steel valves
- 1/2" through 2" size range
- Ideal for mixing, food and chemical applications
- RTFE® seats and seals
- Threaded or socket weld ends
- 4-seat design for high cycle automation
- Self-adjusting stem packing with belleville washers

PRESSURE RATING
1000 PSI CWP
TEMPERATURE RATING
+350° F Maximum
-4° F Minimum

NOTE: not suitable for vacuum service

NOTE: MAXIMUM TEMPERATURE RATING FOR STANDARD ACTUATORS IS 150° F (ELECTRIC) AND 180° (PNEUMATIC). SPECIAL SEALS OR HEAT EXTENSIONS ARE AVAILABLE FOR HIGH TEMPERATURE SERVICE.

SEE PAGE 31 FOR AVAILABLE FLOW PATTERNS

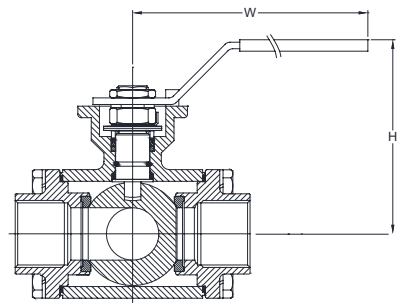
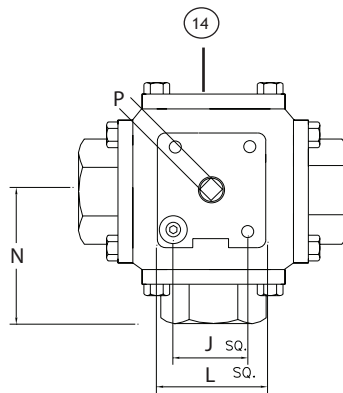
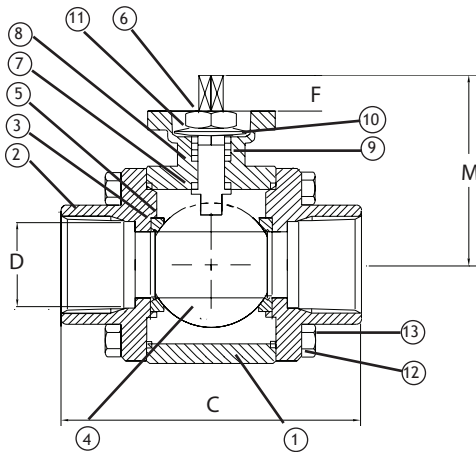

DIMENSIONAL DATA

SIZE	ISO 5211	B	C	D	F	J	L	M	N	P	W	H	WT.
1/2"	F03-F04	3.50	3.78	0.63	0.35	1.42	1.65	2.24	1.89	0.35	7.34	3.50	3.90
3/4"	F04-F05	3.86	4.21	0.79	0.43	1.65	1.97	2.72	2.11	0.43	8.58	3.86	5.65
1"	F04-F05	4.02	4.96	0.98	0.45	1.65	1.97	2.97	2.48	0.43	8.58	4.02	8.85
1-1/4"	F05-F07	4.67	5.24	1.26	0.60	1.97	2.76	3.71	2.62	0.55	9.25	4.67	11.90
1-1/2"	F05-F07	5.00	5.94	1.50	0.56	1.97	2.76	4.05	2.97	0.55	9.25	5.00	18.45
2"	F07-F10	5.47	6.54	1.97	0.70	2.76	4.02	4.87	3.27	0.67	9.92	5.47	23.25

THE MANUAL VERSION OF THIS MODEL STARTS WITH AN "M"

ALL VALVES ARE 100% ELECTRONICALLY TESTED AT 80 PSI IN BOTH THE OPEN AND CLOSED POSITIONS

IS-3WF SERIES FLANGED 3-WAY BALL VALVES

PNEUMATIC ACTUATORS

PNEUMATIC FEATURES

- Rack and pinion design
- NAMUR accessory mounting
- Spring return and double acting
- Visual indicators
- Optional SS construction

ALL STANDARD ACTUATORS SIZED FOR 80 PSI AIR SUPPLY; PLEASE CONSULT FACTORY FOR OTHER COMBINATIONS

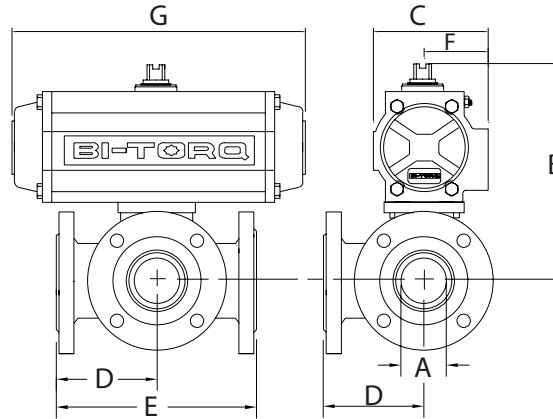

FOR A LIST OF AUTOMATION ACCESSORIES WE CAN OFFER, PLEASE REFER TO PAGE 31 OR VISIT BITORQ.COM

DOUBLE ACTING ASSEMBLY DIMENSIONS								
A	B	C	D	E	F	G	ACT.	WT.
1/2"	5.17	2.79	2.99	5.98	1.61	5.49	52DA	10.3
3/4"	5.43	2.79	3.29	6.57	1.61	5.49	52DA	12.30
1"	5.71	2.79	3.74	7.48	1.61	5.49	52DA	17.30
1-1/4"	6.44	3.17	4.09	8.19	1.77	6.38	63DA	24.30
1-1/2"	7.50	3.72	4.33	8.66	2.07	8.15	75DA	31.30
2"	8.25	3.72	4.98	9.96	2.07	8.15	75DA	53.60
2-1/2"	11.44	5.39	5.91	11.81	2.87	12.91	115DA	72.60
3"	12.14	5.39	6.00	12.01	2.87	12.91	115DA	87.60
4"	12.93	5.39	7.26	14.53	2.87	12.91	115DA	135.6

SPRING RETURN ASSEMBLY DIMENSIONS								
A	B	C	D	E	F	G	ACT.	WT.
1/2"	5.17	2.79	2.99	5.98	1.61	5.49	52SR	10.70
3/4"	5.87	3.17	3.29	6.57	1.77	6.38	63SR	14.00
1"	6.80	3.72	3.74	7.48	2.07	8.15	75SR	22.00
1-1/4"	7.09	3.72	4.09	8.19	2.07	8.15	75SR	29.10
1-1/2"	8.46	4.85	4.33	8.66	2.68	10.69	100SR	43.50
2"	10.39	5.39	4.98	9.96	2.87	12.91	115SR	70.50
2-1/2"	11.91	5.83	5.91	11.81	3.15	14.41	125SR	74.50
3"	14.13	7.35	6.00	12.01	3.94	16.93	161SR	124.8
4"	14.92	7.35	7.26	14.53	3.94	16.93	161SR	173.8

ELECTRIC ACTUATORS

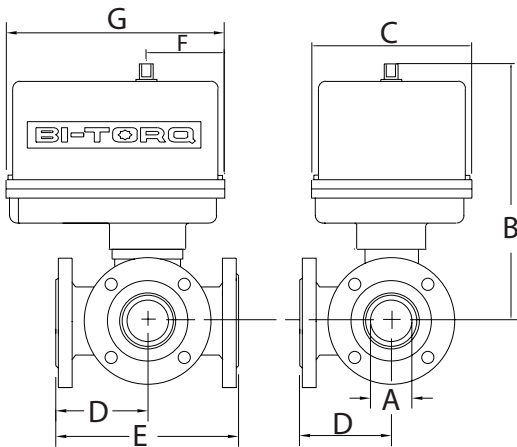

NEMA 4 ELECTRIC ASSEMBLY DIMENSIONS								
A	B	C	D	E	F	G	ACT.	WT.
1/2"	6.53	4.00	2.99	5.98	2.30	5.63	100E	13.00
3/4"	7.79	4.25	3.29	6.57	2.43	6.88	200E	17.00
1"	8.07	4.25	3.74	7.48	2.43	6.88	200E	22.00
1-1/4"	8.36	4.25	4.09	8.19	2.43	6.88	300E	29.00
1-1/2"	10.89*	7.00	4.33	8.66	2.38	7.00	400E	42.00
2"	11.64*	7.00	4.98	9.96	2.38	7.00	675E	61.00
2-1/2"	15.69*	7.00	5.91	11.81	2.38	7.00	1000E	73.00
3"	16.39*	7.00	6.00	12.01	2.38	7.00	1500E	89.00
4"	20.81**	10.00	7.26	14.53	3.75	10.00	2000E	155.00

* DECLUTCHABLE MANUAL OVERRIDE INCLUDED IN DIMENSIONS
 ** MOUNTING KIT INCLUDED IN DIMENSIONS

ELECTRIC FEATURES

- 120VAC, 220VAC, 24VAC, 12VDC and 24VDC
- NEMA 4, 4X and 7 housings
- Manual overrides
- Visual indicators
- Open/close or modulating service

FOR NEMA 7 ELECTRIC DIMENSIONS OR OTHER CONFIGURATIONS, CONTACT OUR SALES STAFF.

FOR MORE INFORMATION ON BI-TORQ ACTUATORS, REFER TO OUR INDIVIDUAL PNEUMATIC AND ELECTRIC CATALOGS, OR VISIT BITORQ.COM.

IS-3WF SERIES FLANGED 3-WAY BALL VALVES

BILL OF MATERIALS

PART #	NAME	MATERIAL	QTY
1	END CAP	CF8M	3
2	BODY	CF8M	1
3	BALL AND STEM	316SS	1
4	BUSHING	TFE	1
5	BALL SEAT	RTFE THRU 2"; TFE 2-1/2" THRU 4"	4
6	BODY SEAL	TFE	4
7	O-RING	VITON	1
8	STEM PACKING	TFE	1
9	PACKING GLAND	304SS	1
10	BELLEVILLE WASHER	301SS	2
11	GLAND NUT	304SS	1
12	HANDLE NUT	304SS	1
13	STOP PIN	304SS	1
14	HANDLE BOLT	304SS	1
15	HANDLE	304SS	1
16	BLIND CAP	CF8M	1
17 - 19	BOLTS AND NUTS	304SS	8
20	BONNET	CF8M	1
21	GASKET	TFE	1

See page 31 for possible pressure limitations due to flow patterns in certain applications with our floating ball valve design.

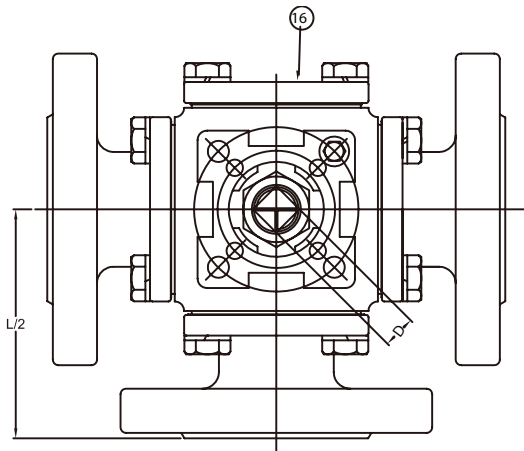

VALVE FEATURES

- 3-Way full port stainless steel valves
- 1/2" through 4" size range
- Ideal for mixing, food and chemical applications
- RTFE® seats through 2"; TFE 2-1/2" - 4"
- ANSI 150# Flanged
- 4-seat design for high cycle automation
- Self-adjusting stem packing w/belleville washers

NOTE: not suitable for vacuum service

PRESSURE RATING
ANSI Class 150
TEMPERATURE RATING
+350° F Maximum
-4° F Minimum

NOTE: MAXIMUM TEMPERATURE RATING FOR STANDARD ACTUATORS IS 150° F (ELECTRIC) AND 180° (PNEUMATIC). SPECIAL SEALS OR HEAT EXTENSIONS ARE AVAILABLE FOR HIGH TEMPERATURE SERVICE.

SEE PAGE 31 FOR AVAILABLE FLOW PATTERNS

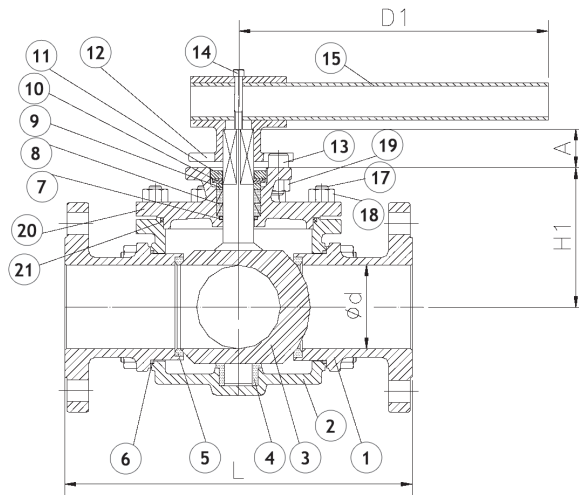

DIMENSIONAL DATA

SIZE	ISO 5211	d	L	L2	H1	A	D1	D	WT.
1/2"	F03-F04	0.59	5.98	2.99	1.65	0.43	5.12	0.35	8.00
3/4"	F04-F05	0.79	6.57	3.29	1.91	0.55	6.50	0.43	10.0
1"	F04-F05	0.98	7.48	3.74	2.19	0.55	6.50	0.43	15.0
1-1/4"	F05-F07	1.26	8.19	4.09	2.48	0.67	8.07	0.55	22.0
1-1/2"	F05-F07	1.50	8.66	4.33	2.89	0.63	8.07	0.55	29.0
2"	F07-F10	1.97	9.96	4.98	3.64	0.83	12.80	0.67	48.0
2-1/2"	F10	2.44	11.81	5.91	4.69	0.98	15.75	0.87	55.0
3"	F10	2.99	12.01	6.00	5.39	0.98	19.69	0.87	71.0
4"	F10	3.78	14.53	7.26	6.18	0.98	23.62	0.87	118

THE MANUAL VERSION OF THIS MODEL STARTS WITH AN "M"

ALL VALVES ARE 100% ELECTRONICALLY TESTED AT 80 PSI IN BOTH THE OPEN AND CLOSED POSITIONS

IC-3P (PVC) & IV-3P (CPVC) SERIES TRUE UNION BALL VALVES

PNEUMATIC ACTUATORS

PNEUMATIC FEATURES

- Rack and pinion design
- NAMUR accessory mounting
- Spring return and double acting
- Visual indicators
- Optional SS construction

ALL STANDARD ACTUATORS SIZED FOR 80 PSI AIR SUPPLY; PLEASE CONSULT FACTORY FOR OTHER COMBINATIONS

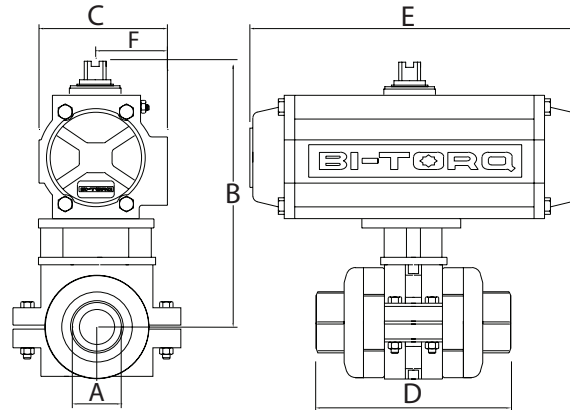

FOR A LIST OF AUTOMATION ACCESSORIES WE CAN OFFER, PLEASE REFER TO PAGE 31 OR VISIT BITORQ.COM

DOUBLE ACTING ASSEMBLY DIMENSIONS							
A	B	C	D	E	F	ACT.	WT.
1/2"	4.84	1.78	4.37	4.65	0.89	32DA	2.52
3/4"	5.45	1.78	4.61	4.65	0.89	32DA	2.86
1"	5.47	1.78	5.31	4.65	0.89	32DA	3.29
1-1/4"	6.38	1.78	6.02	4.65	0.89	32DA	4.30
1-1/2"	7.61	2.79	6.14	5.49	1.61	52DA	6.03
2"	8.01	2.79	7.32	5.49	1.61	52DA	7.98
2-1/2"	8.65	3.17	9.25	6.38	1.77	63DA	17.42
3"	9.16	3.17	10.63	6.38	1.77	63DA	19.34
4"	10.52	3.72	12.13	8.15	2.07	75DA	28.07

SPRING RETURN ASSEMBLY DIMENSIONS							
A	B	C	D	E	F	ACT.	WT.
1/2"	5.80	2.79	4.37	5.49	1.61	52SR	4.12
3/4"	6.41	2.79	4.61	5.49	1.61	52SR	4.46
1"	6.43	2.79	5.31	5.49	1.61	52SR	4.89
1-1/4"	7.34	2.79	6.02	5.49	1.61	52SR	5.90
1-1/2"	8.05	3.17	6.14	6.38	1.77	63SR	8.18
2"	8.45	3.17	7.32	6.38	1.77	63SR	10.13
2-1/2"	10.26	4.85	9.25	10.69	2.68	100SR	30.07
3"	10.77	4.85	10.63	10.69	2.68	100SR	32.09
4"	12.66	5.39	12.13	12.91	2.87	115SR	46.82

ELECTRIC ACTUATORS

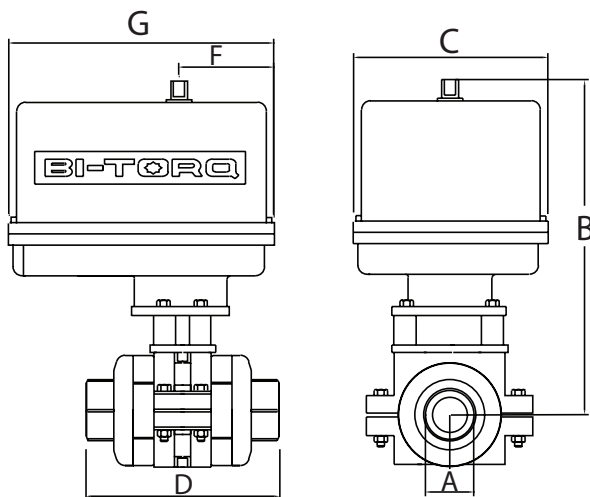

NEMA 4 ELECTRIC ASSEMBLY DIMENSIONS								
A	B	C	D	E	F	G	ACT.	WT.
1/2"	7.16	4.00	4.37	5.63	2.30	5.63	100E	6.47
3/4"	7.77	4.00	4.61	5.63	2.30	5.63	100E	6.81
1"	7.79	4.00	5.31	5.63	2.30	5.63	100E	7.24
1-1/4"	8.70	4.00	6.02	5.63	2.30	5.63	100E	8.25
1-1/2"	8.97	4.00	6.14	5.63	2.30	5.63	100E	9.73
2"	10.37	4.25	7.32	6.88	2.43	6.88	200E	12.68
2-1/2"	10.57	4.25	9.25	6.88	2.43	6.88	300E	22.62
3"	13.20*	7.00	10.63	6.88	2.38	6.88	400E	23.04
4"	13.91*	7.00	12.13	7.00	2.38	7.00	675E	37.47

* DECLUTCHABLE MANUAL OVERRIDE INCLUDED IN DIMENSIONS

ELECTRIC FEATURES

- 120VAC, 220VAC, 24VAC, 12VDC and 24VDC
- NEMA 4, 4X and 7 housings
- Manual overrides
- Visual indicators
- Open/close or modulating service

FOR NEMA 7 ELECTRIC DIMENSIONS OR OTHER CONFIGURATIONS, CONTACT OUR SALES STAFF.

FOR MORE INFORMATION ON BI-TORQ ACTUATORS, REFER TO OUR INDIVIDUAL PNEUMATIC AND ELECTRIC CATALOGS, OR VISIT BITORQ.COM.

IC-3P (PVC) & IV-3P (CPVC) SERIES TRUE UNION BALL VALVES

BILL OF MATERIALS

PART #	NAME	MATERIAL	OPTIONAL MATERIAL	QTY
1	INSERT	PVC	CPVC	1
2	HANDLE	PVC	CPVC	1
3	STEM O-RING	EPDM	VITON	2
4	STEM	PVC	CPVC	1
5	SEAT	PTFE	---	2
6	BALL	PVC	CPVC	1
7	BODY	PVC	CPVC	1
8	SEAT O-RING	EPDM	VITON	2
9	BODY O-RING	EPDM	VITON	2
10	SOCKET O-RING	EPDM	VITON	2
11	CARRIER/STOP RING	PVC	CPVC	1
12	END CONNECTOR	PVC	CPVC	2
13	UNION NUT	PVC	CPVC	2
14	DUAL BLOCK	POM	---	1

VALVE FEATURES

- 2-Way PVC and CPVC valves
- 1/2" through 4" size range
- TFE® seats
- EPDM or Viton® body o-rings
- True union style
- Threaded or socket weld ends
- Patented stem design to help prevent leakage in the event of stem damage

PRESSURE RATING

235 PSI at 73° F

TEMPERATURE RATING

+140° F Maximum PVC

+212° F Maximum CPVC

NOTE: MAXIMUM TEMPERATURE RATING FOR STANDARD ACTUATORS IS 150° F (ELECTRIC) AND 180° (PNEUMATIC). SPECIAL SEALS OR HEAT EXTENSIONS ARE AVAILABLE FOR HIGH TEMPERATURE SERVICE.

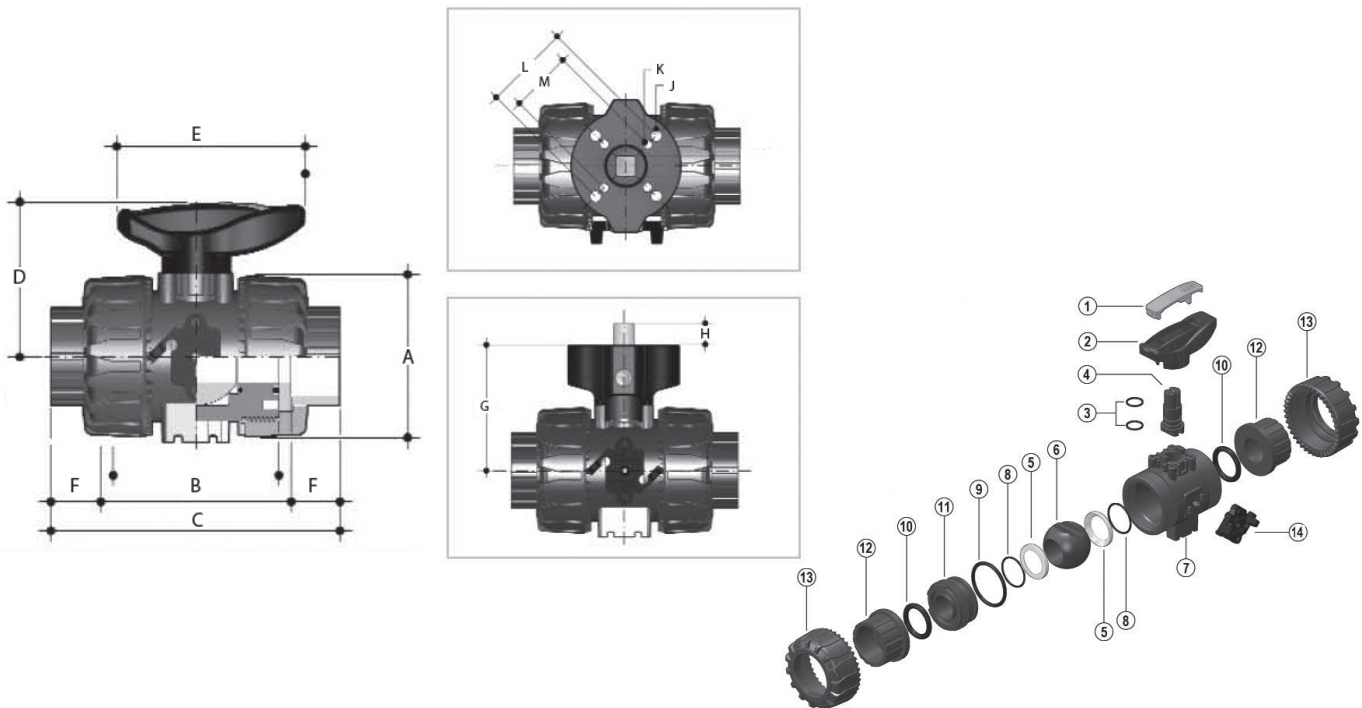

DIMENSIONAL DATA

SIZE	A	B	C	D	E	F	G	H	J	K	L	M	CV	WT.
1/2"	2.13	2.97	4.37	2.13	2.64	0.70	2.28	0.47	0.22	0.22	F04	F03	14.0	0.46
3/4"	2.56	3.19	4.61	2.56	3.35	0.71	2.89	0.47	0.26	0.22	F05	F03	27.0	0.74
1"	2.87	3.54	5.31	2.74	3.35	0.89	2.91	0.47	0.26	0.22	F05	F03	53.9	0.99
1-1/4"	3.39	4.05	6.02	3.25	4.25	0.99	3.82	0.63	0.33	0.26	F05	F07	77.0	1.49
1-1/2"	3.86	4.20	6.14	3.50	4.25	0.97	4.09	0.63	0.33	0.26	F05	F07	123	2.11
2"	4.80	4.99	7.32	4.25	5.28	1.17	4.49	0.63	0.33	0.26	F05	F07	238	3.68
2-1/2"	6.46	6.64	9.25	6.46	8.86	1.31	6.46	0.63	0.35	N/A	N/A	F07	368	9.69
3"	7.99	7.83	10.63	6.97	12.87	1.4	6.97	0.63	0.35	N/A	N/A	F07	497	16.00
4"	9.37	9.17	12.13	7.68	15.16	1.48	7.68	0.75	0.35	N/A	N/A	F07	664	24.50

THE MANUAL VERSION OF THIS MODEL STARTS WITH AN "M"

ALL VALVES ARE 100% ELECTRONICALLY TESTED AT 80 PSI IN BOTH THE OPEN AND CLOSED POSITIONS

IC-3W (PVC) SERIES 3-WAY BALL VALVES

PNEUMATIC ACTUATORS

PNEUMATIC FEATURES

- Rack and pinion design
- NAMUR accessory mounting
- Spring return and double acting
- Visual indicators
- Optional SS construction

ALL STANDARD ACTUATORS SIZED FOR 80 PSI AIR SUPPLY; PLEASE CONSULT FACTORY FOR OTHER COMBINATIONS

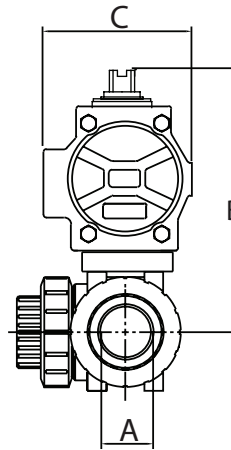
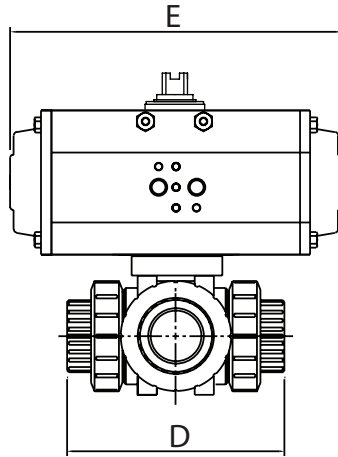

FOR A LIST OF AUTOMATION ACCESSORIES WE CAN OFFER, PLEASE REFER TO PAGE 31 OR VISIT BITORQ.COM

DOUBLE ACTING ASSEMBLY DIMENSIONS							
A	B	C	D	E	F	ACT.	WT.
1/2"	6.69	1.78	4.96	4.65	0.89	32DA	3.47
3/4"	7.08	1.78	5.76	4.65	0.89	32DA	3.76
1"	7.40	1.78	6.56	4.65	0.89	32DA	4.03
1-1/4"	7.97	1.78	7.71	4.65	0.89	32DA	4.73
1-1/2"	9.40	2.79	8.32	5.49	1.61	52DA	7.88
2"	9.58	2.79	9.99	5.49	1.61	52DA	9.38

SPRING RETURN ASSEMBLY DIMENSIONS							
A	B	C	D	E	F	ACT.	WT.
1/2"	7.65	2.79	4.96	5.49	1.61	52SR	5.07
3/4"	8.04	2.79	5.76	5.49	1.61	52SR	5.36
1"	8.36	2.79	6.56	5.49	1.61	52SR	5.63
1-1/4"	8.93	2.79	7.71	5.49	1.61	52SR	6.33
1-1/2"	9.84	3.17	8.32	6.38	1.77	63SR	8.53
2"	10.02	3.17	9.99	6.38	1.77	63SR	10.03

ELECTRIC ACTUATORS

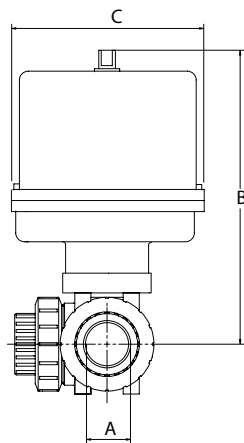
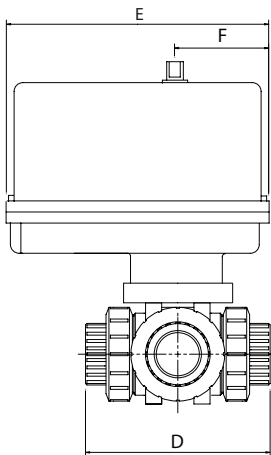

NEMA 4 ELECTRIC ASSEMBLY DIMENSIONS							
A	B	C	D	E	F	ACT.	WT.
1/2"	9.01	4.00	4.96	5.63	2.30	100E	7.42
3/4"	9.40	4.00	5.76	5.63	2.30	100E	7.71
1"	9.72	4.00	6.56	5.63	2.30	100E	7.98
1-1/4"	10.29	4.00	7.71	5.63	2.30	100E	8.68
1-1/2"	11.76	4.25	8.32	6.88	2.43	200E	11.58
2"	11.94	4.25	9.99	6.88	2.43	200E	14.08

ELECTRIC FEATURES

- 120VAC, 220VAC, 24VAC, 12VDC and 24VDC
- NEMA 4, 4X and 7 housings
- Manual overrides
- Visual indicators
- Open/close or modulating service

FOR NEMA 7 ELECTRIC DIMENSIONS OR OTHER CONFIGURATIONS, CONTACT OUR SALES STAFF.

FOR MORE INFORMATION ON BI-TORQ ACTUATORS, REFER TO OUR INDIVIDUAL PNEUMATIC AND ELECTRIC CATALOGS, OR VISIT BITORQ.COM.

IC-3W (PVC) SERIES 3-WAY BALL VALVES

BILL OF MATERIALS

PART #	NAME	MATERIAL	OPTIONAL MATERIAL	QTY
1	HANDLE	PVC	---	1
2	STEM O-RING	EPDM	VITON	1
3	STEM	PVC	CPVC	1
4	BODY	PVC	CPVC	1
5	BALL	PVC	CPVC	1
6	BODY O-RING	EPDM	VITON	3
7	BALL SEAT SUPPORT	TFE	---	3
8	BALL SEAT	TFE	---	3
9	SOCKET O-RING	EPDM	VITON	3
10	UNION NUT	PVC	CPVC	3
11	END CONNECTOR	PVC	CPVC	3
12	END CONNECTOR O-RING	EPDM	VITON	3

VALVE FEATURES

- 3-Way PVC (CPVC optional)
- 1/2" through 2" size range
- TFE® seats
- EPDM or Viton® body o-rings
- True union style
- Threaded or socket weld ends
- 3-seat design ideal for automation

PRESSURE RATING
235 PSI at 73° F

TEMPERATURE RATING
+140° F Maximum PVC
+212° F Maximum CPVC

NOTE: MAXIMUM TEMPERATURE RATING FOR STANDARD ACTUATORS IS 150° F (ELECTRIC) AND 180° (PNEUMATIC). SPECIAL SEALS OR HEAT EXTENSIONS ARE AVAILABLE FOR HIGH TEMPERATURE SERVICE.

SEE PAGE 31 FOR AVAILABLE FLOW PATTERNS

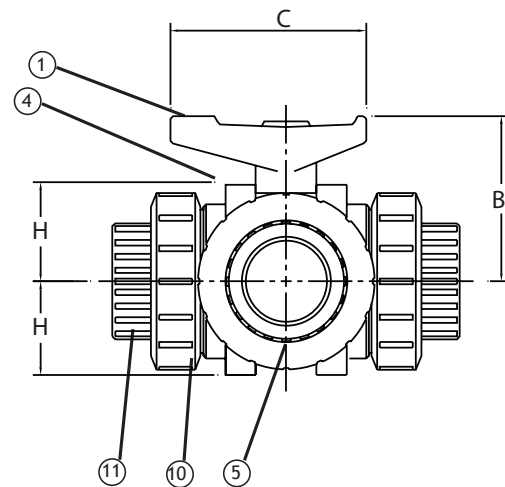
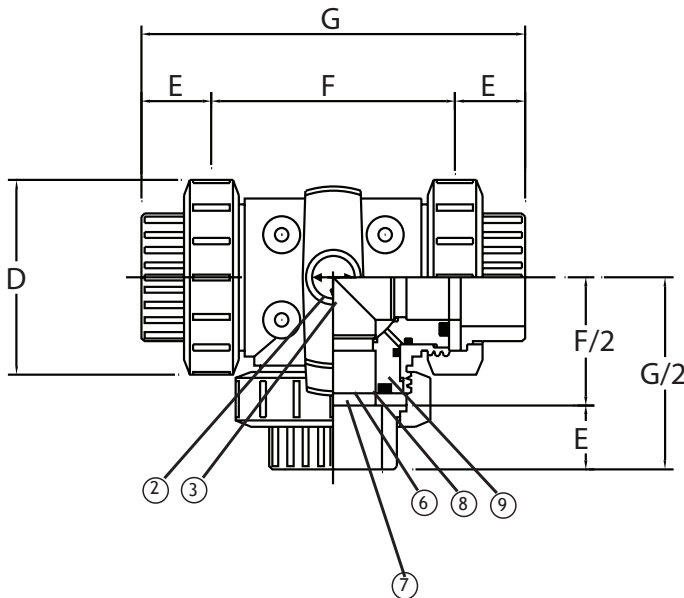

DIMENSIONAL DATA

SIZE	B	C	D	E	F	G	H	J	K	CV*	WT.
1/2"	2.00	2.56	2.13	0.71	3.15	4.96	4.25	0.94	0.94	13.7	0.68
3/4"	2.36	2.99	2.56	0.71	3.94	5.76	5.04	0.98	1.22	26.6	1.21
1"	2.64	3.35	2.87	0.89	4.33	6.56	5.67	1.06	1.57	53.20	1.74
1-1/4"	2.95	3.94	3.39	0.99	5.16	7.71	6.81	1.26	1.61	73.50	2.81
1-1/2"	3.50	4.41	3.86	0.97	5.83	8.32	7.76	1.28	2.09	119	3.66
2"	4.13	5.39	4.80	1.17	7.05	9.99	8.12	1.38	2.28	224	6.17

* STRAIGHT THROUGH PORT

THE MANUAL VERSION OF THIS MODEL STARTS WITH AN "M"

ALL VALVES ARE 100% ELECTRONICALLY TESTED AT 80 PSI IN BOTH THE OPEN AND CLOSED POSITIONS

INSTRUPAK BALL VALVE PART NUMBERING GUIDE

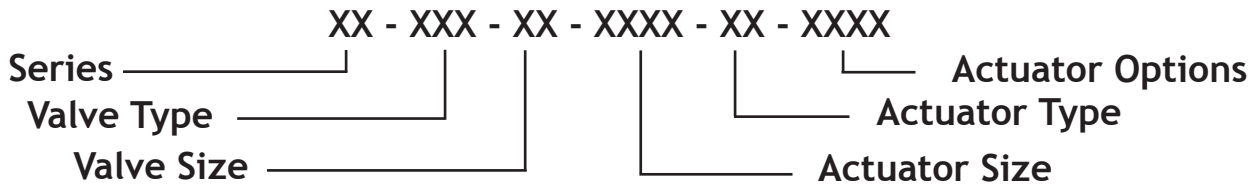

INSTRUPAK AUTOMATED SERIES

IP*	BRASS
IB	BRASS W/SS TRIM
IS*	STAINLESS STEEL
FS	FIRE SAFE (SS)
FW	FIRE SAFE (WCB)
IC*	PVC
IV*	CPVC
HPS	HIGH PRESSURE FIRE SAFE

* Manual series start with "M" instead of an "I"
 Manual series models end with Valve Size

VALVE TYPE

2P	TWO-PIECE THREADED
3PT	THREE-PIECE THREADED
3PS	THREE-PIECE SOCKET
3WL	3-WAY L-PORT THREADED
3WT	3-WAY T-PORT THREADED
3WLF	3-WAY L-PORT FLANGED
3WTF	3-WAY T-PORT FLANGED
2PF	2-PIECE FLANGED
3TC	3-PIECE TRI-CLAMP
3WTTC	3-WAY T-PORT TRI-CLAMP
3WLTC	3-WAY L-PORT TRI-CLAMP

VALVE SIZE

02	1/4"	10	1"	25	2-1/2"
03	3/8"	12	1-1/4"	30	3"
05	1/2"	15	1-1/2"	40	4"
07	3/4"	20	2"	60	6"

ACTUATOR ONLY PART # GUIDE

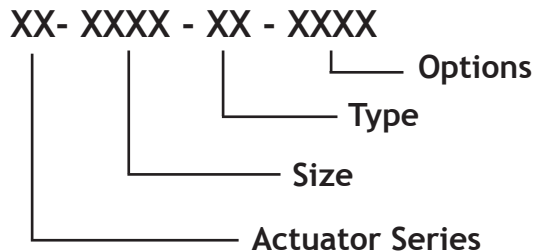

ACTUATOR SIZE

32	PN-32	100	BI-100	45	SS-45
52	PN-52	200	BI-200	60	SS-60
63	PN-63	300	BI-300	85	SS-85
75	PN-75	400	BI-400	105	SS-105
88	PN-88	675	BI-675	125	SS-125
100	PN-100	1000	BI-1000	140	SS-140
115	PN-115	1500	BI-1500	160	SS-160
125	PN-125	2000	BI-2000	266	BH-266
145	PN-145	3800	BI-3800	310	BH-310
161	PN-161			440	BH-440
181	PN-181			880	BH-880
201	PN-201			1770	BH-1770
241	PN-241			3540	BH-3540
271	PN-271			5310	BH-5310

PN - RACK & PINION
 SS - 304SS RACK & PINION
 BI - ELECTRIC
 BH - PREMIUM ELECTRIC

ACTUATOR SERIES

ACTUATOR TYPE

DA	DOUBLE ACTING PNEUMATIC
SR	SPRING RETURN PNEUMATIC
E	ELECTRIC (ONLY ON BI SERIES PART#S)

ELECTRIC ACTUATOR OPTIONS

A	115VAC	2S*	2 AUX. SWITCHES
B	24VDC	VP	4-20Ma POSITIONER
C	24VAC	HT*	HEATER THERMOSTAT
F	12VDC	TX**	4-20Ma TRANSMITTER
H	230VAC	ED	EXTENDED DUTY
4	NEMA 4	R	HEATER ONLY
4X*	NEMA 4X		* std. on BH series
7	NEMA 7		** included with VP on BH series

PNEUMATIC ACTUATOR OPTIONS

V	VITON SEALS
##	SPRING SET

FOR EXAMPLE: IP-2P-20-200-E-A-4-2S-HT = 2" FULL PORT BRASS BALL VALVE AND 115VAC ELECTRIC ACTUATOR WITH NEMA 4 ENCLOSURE, 2 AUXILIARY LIMIT SWITCHES AND HEATER/THERMOSTAT

FOR IS-3W, IS-3WF, IC-3W, AND IP-3W VALVES

T-PORT DESIGN

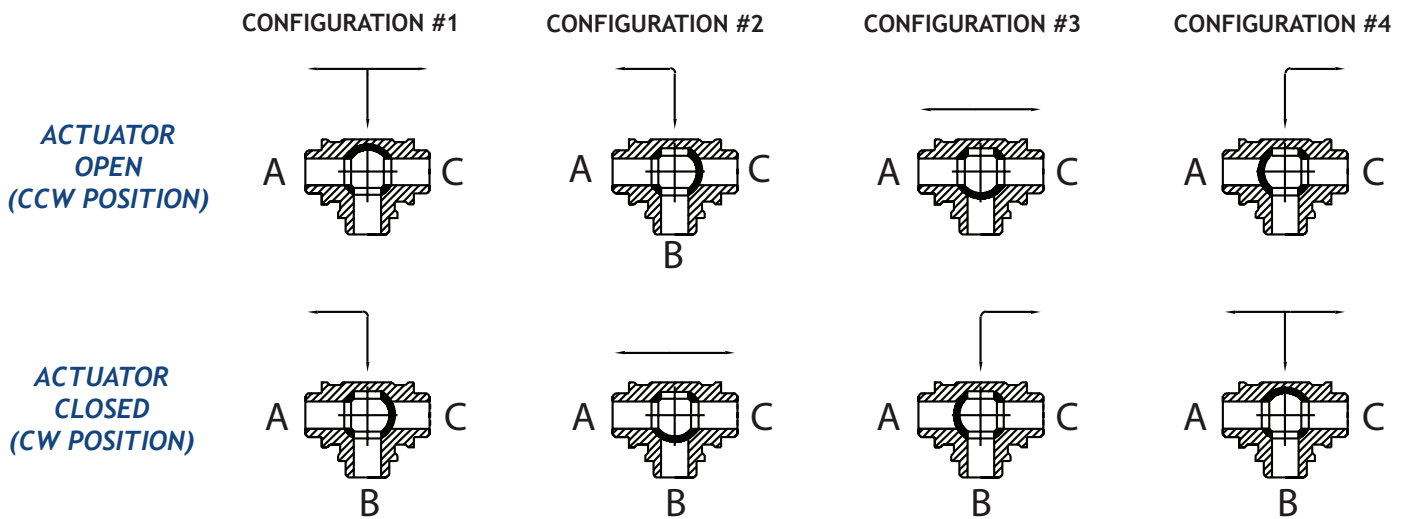

L-PORT DESIGN

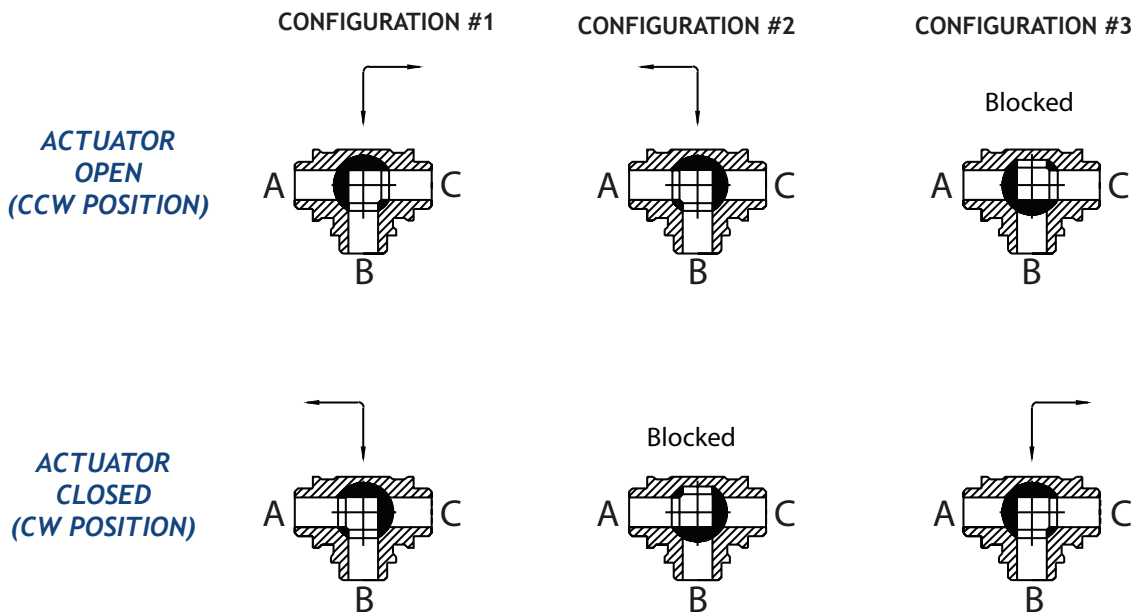

PLEASE CONSULT BI-TORQ FOR REVERSING ACTING ACTUATORS AND OTHER FLOW PATTERN OPTIONS NOT LISTED

APPLICATION LIMITATION (FLOATING VALVE DESIGN)

Referring to the diagram to the right, there is a limitation on the differential pressure between flow P2 and P1. Where $P2 > P1$, leakage from P2 to P1 could occur. The same logic follows for other L/T flow patterns. The limitation is 150 PSI.

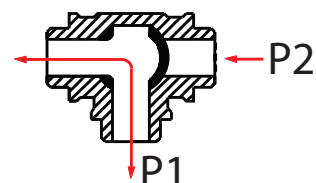

PNEUMATIC AND ELECTRIC ACTUATORS

ALL INSTRUPAK BALL VALVES ARE AUTOMATED WITH HIGH QUALITY ELECTRIC AND PNEUMATIC ACTUATORS. SOME ACTUATOR FEATURES ARE LISTED BELOW. FOR MORE COMPREHENSIVE INFORMATION ON BI-TORQ® ACTUATORS, PLEASE REFER TO OUR INDIVIDUAL PNEUMATIC AND ELECTRIC CATALOGS OR VISIT WWW.BITORQ.COM.

PNEUMATIC ACTUATORS



- HEAVY DUTY RACK AND PINION DESIGN
- SPRING RETURN AND DOUBLE ACTING
- DUAL ADJUSTMENT STOPS STANDARD
 - TOP MOUNT INDICATOR
- HIGH TEMPERATURE AND CORROSION RESISTANT MODELS AVAILABLE
 - TRUE NAMUR AND ISO MOUNTING
- SOLENOIDS, LIMIT SWITCHES, POSITIONERS AND OTHER ACCESSORIES ARE AVAILABLE

ELECTRIC ACTUATORS

- COMPACT, HIGH TORQUE DESIGN
- 115VAC, 24VAC, 12VDC, 24VDC, 230VAC
- EASILY ADJUSTABLE LIMIT SWITCHES
 - TOP MOUNT INDICATOR
 - MANUAL OVERRIDE
- MODULATING SERVICE POSITIONER BOARDS, AUXILIARY SWITCHES, HEATERS, TIMER BOARDS AND MANY OTHER OPTIONS AVAILABLE



AUTOMATION ACCESSORIES

BI-TORQ VALVE AUTOMATION OFFERS A WIDE VARIETY OF ACCESSORIES FOR OUR AUTOMATED BALL VALVE ASSEMBLIES. ALL ACCESSORY COMPONENTS ARE MOUNTED AND TESTED ON THE ACTUATOR BY OUR TRAINED FACTORY PERSONNEL.



**ANALOG & SMART
MODULATING POSITIONERS**



**LIMIT SWITCH
POSITION INDICATORS**



**NAMUR MOUNT
SOLENOIDS**



**CUSTOMIZED
ASSEMBLIES**

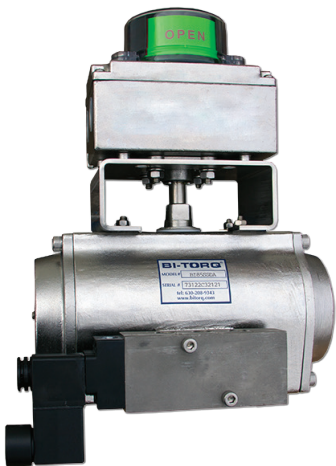

**ALL STAINLESS
OPTIONS**

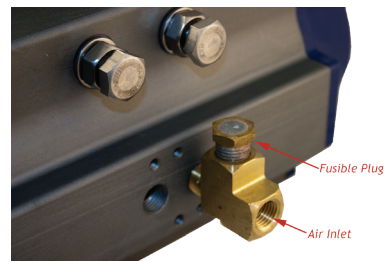

**FUSIBLE
PLUGS**



**AUTOMATED VALVES • RETROFIT ACTUATION PACKAGES • SAFETY PRODUCTS
THERMAL SHUT-OFF ASSEMBLIES • CUSTOMIZED MOUNTING SOLUTIONS**

WHAT YOU CAN EXPECT FROM US...

Everyone at BI-TORQ works from a singular point of view that we call the BI-TORQ way. Simply put, this means we will do whatever it takes to make things as easy as possible, always do the right thing and wholeheartedly stand by our products.



**EXPERT TECHNICAL
ADVICE**



**QUALITY
PRODUCTS**



**SAME DAY
QUOTES**



**QUICK
SHIPMENTS**



**PRODUCT
INTERCHANGES**



**COST
SAVINGS**

PRODUCT SNAPSHOT

VALVES

- BALL VALVES
- BUTTERFLY VALVES
- KNIFE GATE VALVES
- FIRE SAFE VALVES

ACTUATORS

- ELECTRIC ACTUATORS
- PNEUMATIC RACK AND PINIONS
- FAIL SAFE ACTUATORS
- GEAR OPERATORS

SAFETY PRODUCTS

- THERMAL SHUT-OFF VALVES
- SPRING RETURN HANDLES
- FUSIBLE PLUGS
- LOCK-OUT KITS

ACCESSORIES

- LIMIT SWITCHES
- POSITIONERS
- NAMUR SOLENOIDS
- DECLUTCH OVERRIDES

CUSTOM HARDWARE

- MOUNTING KITS
- STEM EXTENSIONS
- TANDEM LINKAGES
- TEE LINKAGES



YOUR ONE-STOP SHOP FOR VALVE AUTOMATION!

1N050 LINLAR DRIVE | LA FOX, IL
 TEL: 630-208-9343 | SALES@BITORQ.COM
 BITORQ.COM