



AMERICAN-MARSH PUMPS

“DURABILITY BY DESIGN SINCE 1873”

460 Series Process Pumps ANSI B73.1M Standard

Flows to: 7,400 GPM

Heads to: 985 Feet

Temperatures to: 700° F

140 Years of Pump Manufacturing

American-Marsh Pumps, one of the oldest pump lines in America, are pump products steeped in heritage. Since 1873, the American-Marsh line of pumps has withstood the test of time. During the last 140 years, over 100 varieties of pumps have been designed and built. From steam pumps to centrifugal pumps, American-Marsh pumps have been built to meet the ever changing requirements of society. Over the last century through continuous product development, more American-Marsh models have been retired than most other pump manufacturers have ever produced. Hundreds of thousands of pumps have been made, all designed for longevity, allowing many of them to continue servicing customers over 50 years.

All of our pumps have three superior characteristics; Design, Performance, and Durability. Our engineering department, which includes an in-house pattern shop, designs each pump so that installation and maintenance is easy. Our performances are engineered to meet or beat the competition in each category. For 140

years, American-Marsh Pumps products have provided cost effective solutions by building pumps to last. Durability by design is always the most cost effective solution. From engineering and design to final assembly, experienced people control each step of the manufacturing process with quality control inspections performed at each step. All pumps shafts are heat straightened. All impellers are computer balanced. Pump testing is done in our new state of the art test facility. All of these factors ensure you receive consistent quality product every time.

American-Marsh Pumps has provided quality pump products for over 140 years. At American-Marsh Pumps, we know that long life and superior performance are the keys to satisfied customers. By understanding your needs, we can design products that meet those needs. Our product family reflects years of customer input, product upgrades, redesign and new product development, all focused on meeting and exceeding your expectations.

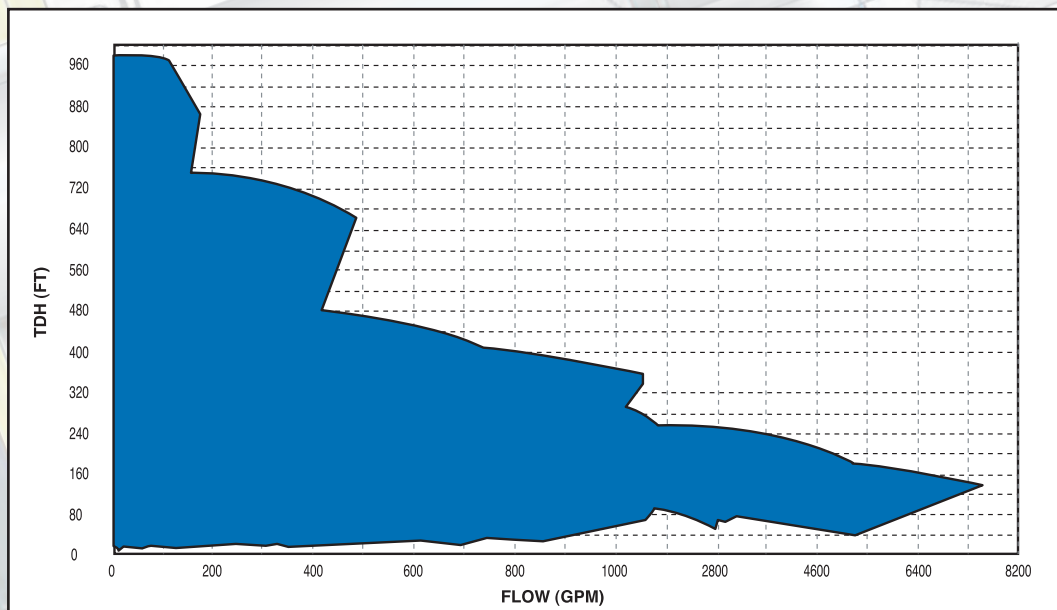



Specifications

OSD & OSG Series

Casing: The casing is constructed of high tensile cast steel, ductile iron or other specified material. It is of the volute type, carefully and accurately proportioned to permit smooth flow and to convert high velocity energy of the fluid as it leaves the impeller into pressure. Suction and discharge nozzles are flanged and are cast integral with the volute.

OSD & OSG models have cast integral feet standard and the discharge port is of the vertical centerline type. The casing assembly fully meets ANSI B73.1M dimensional requirements. Necessary vent and drain openings can be provided upon request. OSD Low Flo models feature concentric casings that minimize shaft deflection and pump vibration.

Impeller: The OSD impeller is of the reverse vane, end suction type, casted in one piece of cast steel or other specified material. Running clearances need to only be adjusted between the back of the impeller and the casing adapter. This design allows for repeatable factory tolerances, all of which can be adjusted on the bench, not just in the field. All impellers are hydraulically and dynamically balanced prior to assembly. The OSG impeller is of the semi-open, end suction type, casted in one piece of ductile iron or other specified material. Running clearances need to be adjusted between the front of the impeller and the casing. All models meet the stringent performance requirements of ANSI B73.1M. American-Marsh also offers 6 Low-Flow (LF) models to meet difficult low-flow/high-head process applications.

Shaft: The shaft is of high strength steel or other specified material, ground to accurate dimensions and polished to a smooth surface. It is designed for extra stiffness to avoid all critical speeds in operation. OSD pumps lead the industry in low L3/D4 ratio's minimizing shaft deflection at the stuffing box. All OSD & OSG models guarantee less than 0.002" shaft deflection at the seal face location, while in operation. As an option, the shaft can be protected by a shaft sleeve of ample thickness to ensure long life. The shaft sleeve can be supplied in various materials.

Seal Chamber: The OSD pump has seal chambers available in five (5) different configurations depending on the jobsite requirement. OSD pumps feature the Flow Modified (FM) seal chamber that keeps solid matter from collecting in the seal chamber causing premature seal failure. The FM bores are available in a small bore (FMS), a large bore (FML) and a small bore with cast integral gland (FMI), all designed to meet the pro-

cess requirements of the seal industry. OSD models can also be supplied in a standard Cylindrical Bore (CB) arrangement. The CB bores are available in a small bore (CBS) and large bore (CBL) both designed to meet the process requirements of the seal industry. The OSG pump has seal chambers available in two (2) different configurations depending on the jobsite requirement. OSG pumps feature the Flow Modified (FM) seal chamber that keeps solid matter from collecting in the seal chamber causing premature seal failure. The CB bores are available in a small bore (CBS) designed to meet the process requirements of the seal industry. Seal chambers have provisions for various flush plan arrangements customizing the seal chamber to meet the requirements of the end user. For abrasive applications, packing with a lantern ring can also be supplied. A wide variety of component and cartridge mechanical seals can be used with OSD & OSG standard components.

Power Frame: The power frame is constructed of high tensile cast iron and provides support for the inboard and outboard bearings. The outboard bearing is of the double row, angular contact type and the inboard bearing is of the single row, deep groove type for excellent axial and radial load support. On OSD models, axial adjustment of the impeller employs a micrometer adjustment which allows the user to dial back factory tolerances between the impeller and the seal chamber. This re-adjustment of tolerances can be done on the bench, compensating for proper seal setting and eliminating the need to have the casing near for final adjustment. On OSG models, axial adjustment of the impeller employs a micrometer adjustment which allows the user to dial back factory tolerances between the impeller and the pump casing. Bearing isolators ensure that contaminants are kept out of the power frame. For extremely crucial applications, magnetic bearing isolators with a poppet breather can be specified, hermetically sealing the power frame. The power frame has an oversized, integral oil sump that provides oil for lubrication to each bearing. A large one inch oil level eye is provided standard on the power frame to visually indicate the oil level. The OSD bearings and shafts are so designed to last up to 61% longer than the competition. With OSD shaft deflection indices surpassing nearly all of the competition, 43-252% greater stiffness is achieved resulting in longer Mean Time Between Planned Maintenance (MTBPM).

Model OSD ANSI Pump

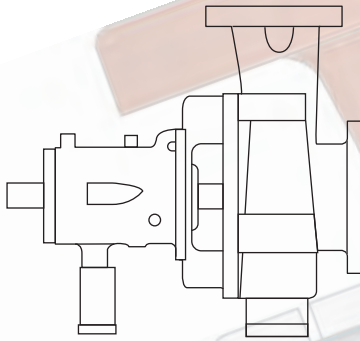

Reverse Vane Impeller



Semi-Open Impeller



Low Flow Impeller

Flows To: 7,400 GPM
Heads To: 985 Feet
Temps To: 700° F

Markets:

- Chemical
- Food & Beverage
- General Industry
- Marine
- Mining & Aggregate
- Oil & Gas
- Power Generation
- Petro-Chemical
- Pharmaceutical
- Pulp & Paper
- Water & Wastewater

Power Frame

- Heavy duty ductile iron
- Single row inboard and double row outboard bearings
- Oil lubricated with extra large oil sump
- Oversized oil level eye
- Double lip oil seals
- Top vent/breather
- Optional bearing isolators
- Optional grease lubrication

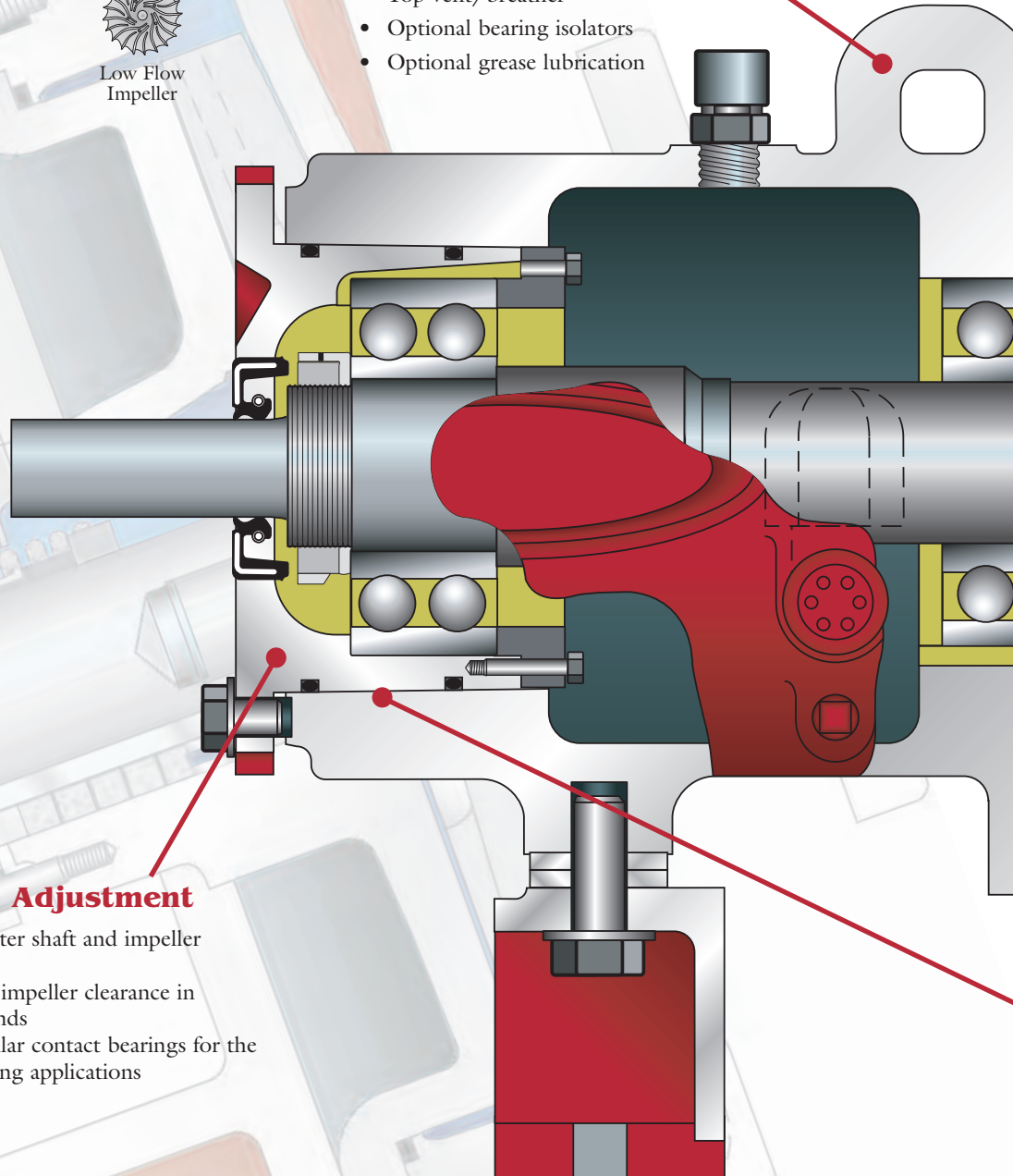

Power Frame Adjustment

- Micro-millimeter shaft and impeller adjustment
- Accurately set impeller clearance in 15 to 20 seconds
- Optional angular contact bearings for the most demanding applications

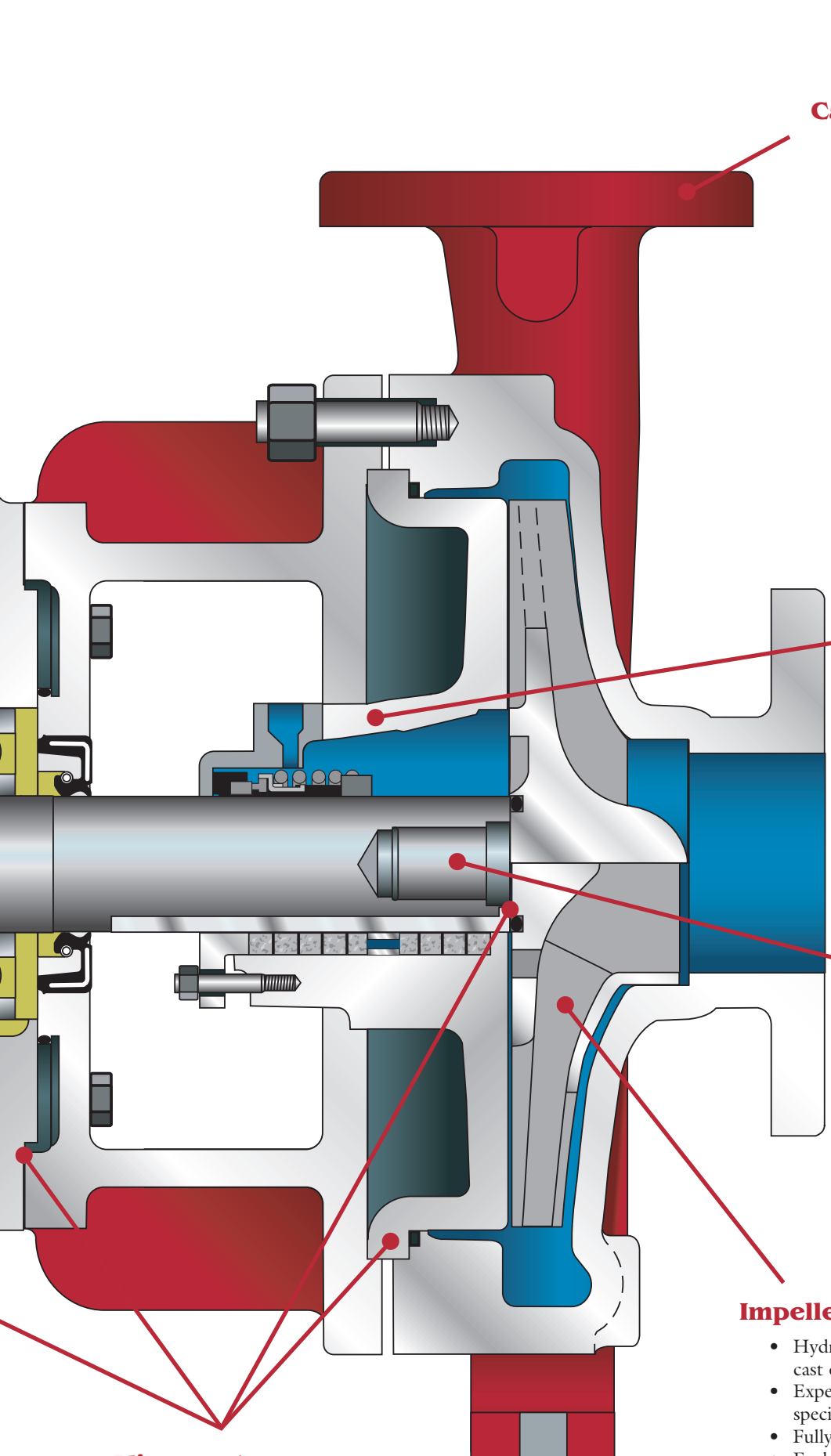

Casing

- Standard cast steel or other specified material
- Fully meets ANSI B73.1M standards
- Heavy wall thickness to provide for generous corrosion allowance
- Fully cast integral feet for support when utilizing “back-pull-out” feature
- Centerline discharge transmits residual pipe strain to feet of casing and allows for self venting
- Class 150 pound flat face flanges standard
- Optional 150# raised face, 300# flat face and 300# raised face suction and discharge flanges

Engineered Seal Chambers

- Five (5) seal chambers available depending on application (FML, FMS, FMI, CBL & CBS)
- Extend mechanical seal life
- Utilize less expensive seals and flush plans
- Improve pump reliability
- Optional packing for abrasive applications
- Optional jacketed seal chambers

Shaft

- Designed and sized especially for the pump and its applications
- Investment cast or high alloy bar stock available
- Solid, hook sleeve, friction welded or composite shafts available
- Offset keyways to aid shaft balance
- Runout of <0.001 inches at mechanical seal allows seal faces to run true

Impeller

- Hydraulically balanced one piece investment cast of cast steel or other alloy
- Expertly machined to customer specifications
- Fully balanced prior to assembly
- Exclusive reverse vane design that offers repeatable pump performance
- Optional front semi-open impeller

Alignment

- Four precision machined metal-to-metal fit locations (other manufacturers offer only two)
- Precision machined metal-to-metal bearing carrier reduces stack-ups to improve shaft concentricity

Model OSG ANSI Pump

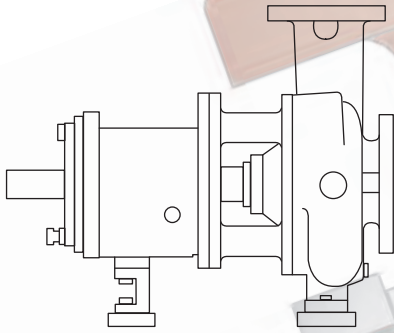

Semi-Open
Impeller

Flows To: 7,000 GPM
Heads To: 730 Feet
Temps To: 700° F

Markets:

-  Chemical
-  Food & Beverage
-  General Industry
-  Marine
-  Mining & Aggregate
-  Oil & Gas
-  Power Generation
-  Petro-Chemical
-  Pharmaceutical
-  Pulp & Paper
-  Water & Wastewater

M-Power Frame

- Unique and industry leading micrometer impeller adjustment
- Heavy duty cast iron
- Single row inboard and double row outboard bearings
- Oil lubricated with extra large oil sump
- Oversized oil level eye
- Double bearing isolators
- Top vent/breather
- Optional grease lubrication

Power Frame Adjustment

- Micro-millimeter shaft and impeller adjustment
- Accurately set impeller clearance in 15 to 20 seconds
- Optional angular contact bearings for the most demanding applications

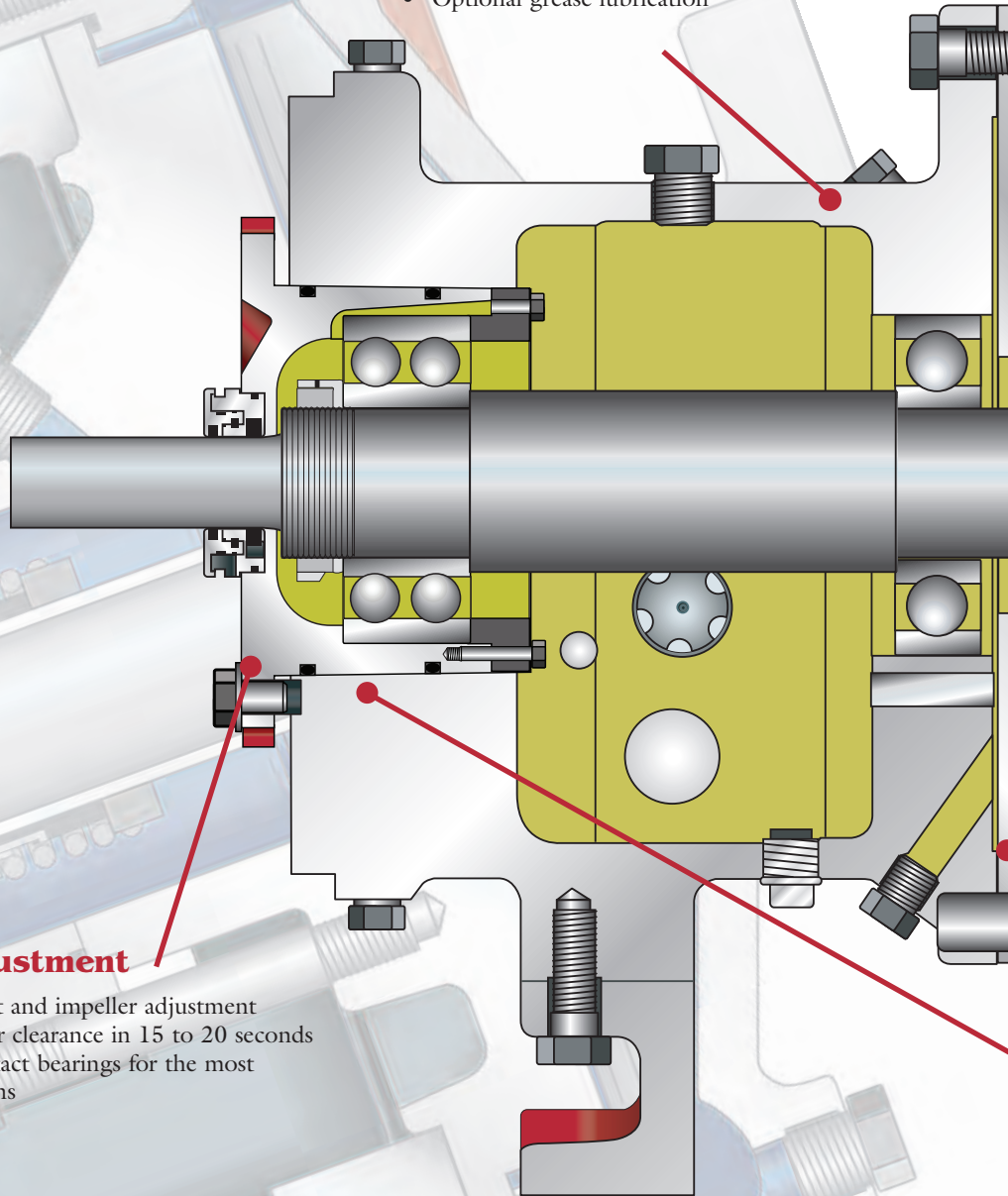

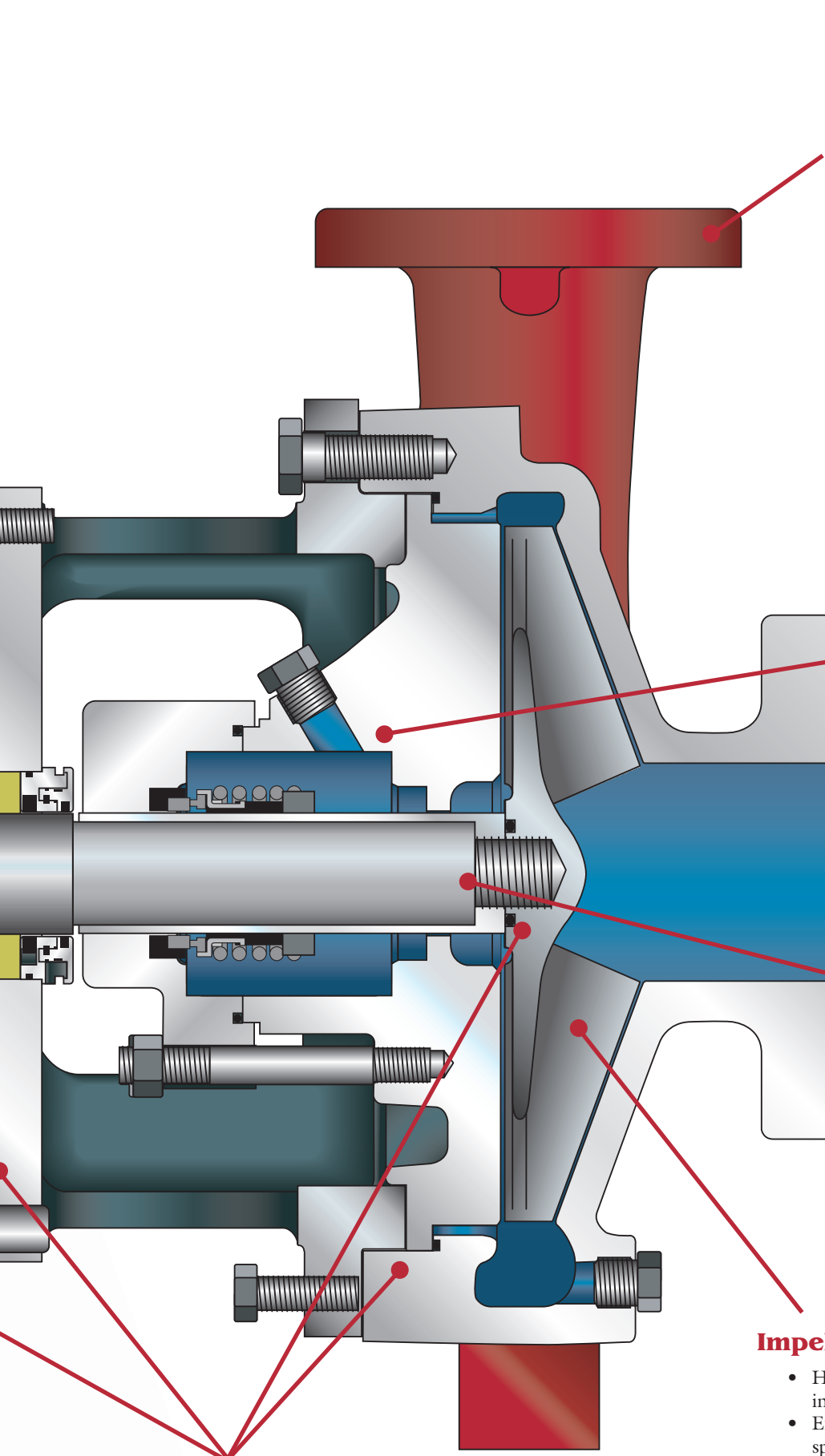

Casing

- Standard ductile iron or other specified material
- Fully meets ANSI B73.1M standards
- Heavy wall thickness to provide for generous corrosion allowance
- Fully cast integral feet for support when utilizing “back-pull-out” feature
- Centerline discharge transmits residual pipe strain to feet of casing and allows for self venting
- Class 150 pound flat face flanges standard
- Optional 150# raised face, 300# flat face and 300# raised face suction and discharge flanges

Engineered Seal Chambers

- Five (5) seal chambers available depending on application (FML, FMS, FMI, CBL & CBS)
- Extend mechanical seal life
- Utilize less expensive seals and flush plans
- Improve pump reliability
- Optional packing for abrasive applications

Shaft

- Designed and sized especially for the pump and its applications
- Investment cast or high alloy bar stock available
- Solid or hook sleeve shafts available
- Offset keyways to aid shaft balance
- Runout of <math><0.001</math> inches at mechanical seal allows seal faces to run true

Impeller

- Hydraulically balanced, semi-open, investment cast of ductile iron or other alloy
- Expertly machined to customer specifications
- Fully balanced prior to assembly

Alignment

- Four precision machined metal-to-metal fit locations (other manufacturers offer only two)
- Precision machined metal-to-metal bearing carrier reduces stack-ups to improve shaft concentricity

OSD & OSG Fluid End

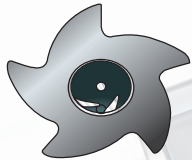
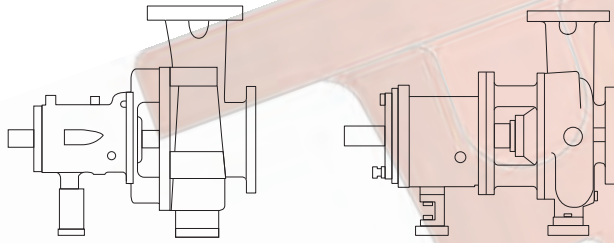

Exclusive reverse vane impeller with balance holes offers important performance enhancing maintenance reducing advantages. Repeatable performance and seal chamber pressures allow repeatable MTBPM cycle.



Front vane, semi-open impeller is fully interchangeable with the reverse vane impeller. Excellent choice for stringy and certain applications requiring high shear against the casing.



Front vane, Low-Flo, semi-open impeller for operation at low flow with minimal thrust loads and vibration. Radial loads are reduced up to 90% and shaft vibration is reduced up to 50% at low flows.

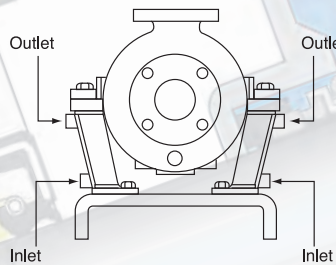

Centerline mounted casings (OSO Hot Oil) are used to reduce loads caused by thermal expansion. Jacketed feet with inlet/outlet ports further assure effective temperature control.

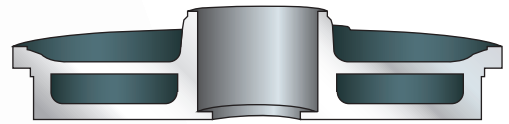

Jacketed standard bore (CBS) is recommended when cooling the seal chamber is the objective.

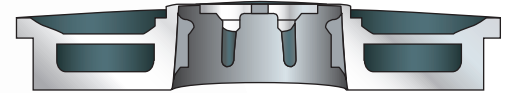

Jacketed FM chamber is preferred when protection of the process temperature is important.

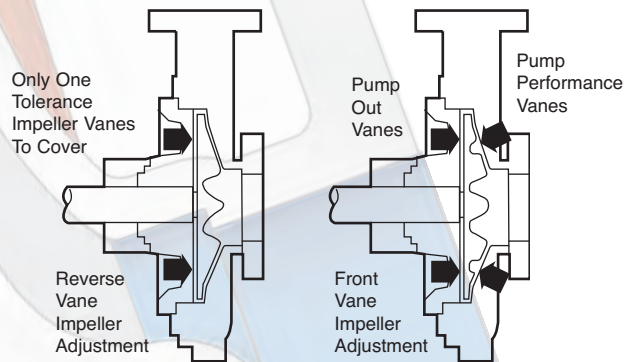

Only an American Marsh reverse vane impeller offers repeatable performance after wear and impeller adjustment.

An impeller cannot be adjusted to two locations. Seal and bearing life are reduced due to increased loads after wear and maintenance adjustment.

Optional Connections

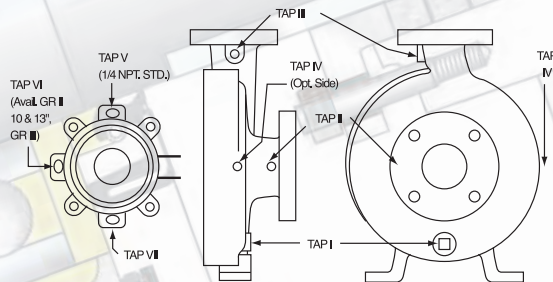

Item	Part	Typical Size
I	Casing Drain	3/4" (19 mm)-10, 1/2" (13 mm) NPT, 3/4" (19 mm) NPT
II	Suction Nozzle Gage Connection	1/4" (6 mm) NPT
III	Discharge Nozzle Gage Connection	1/4" (6 mm) NPT
IV	Connection for Line to Seal Chamber	1/4" (6 mm) NPT
V	Connection for Line to Seal Chamber	1/4" (6 mm) NPT
VI	Flush Connection for Mechanical Seal	1/4" (6 mm) NPT
VII	Bottom Tap in Seal Chamber	1/4" (6 mm) NPT

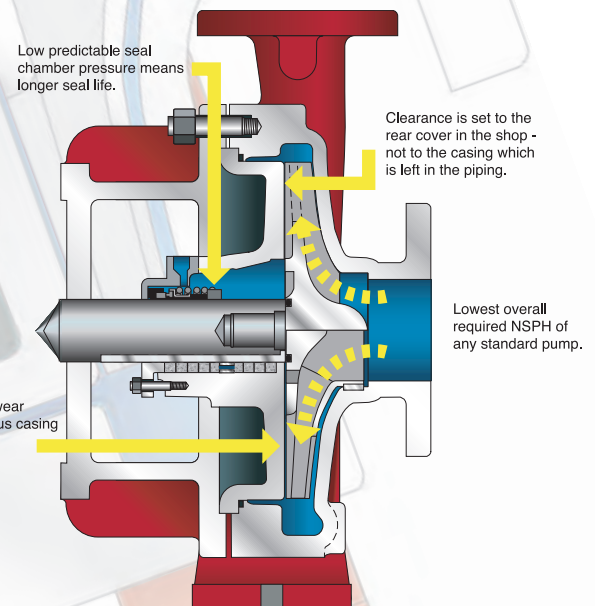

Lowest overall required NSPH of any standard pump.

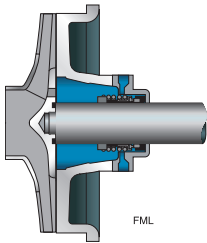

FML

Oversized, tapered bore with 8 specially shaped and evenly spaced cast-in flow modifiers. Designed for seals with large gland bolt and gasket circles.

- Single internal cartridge seals.
- Dual internal/external cartridge seals.
- Single internal component seals with flexibly mounted seats.*
- Dual internal “true” tandem cartridge seals.

Note: Bypass flush to internal seal normally not required. Barrier fluid or external flush may apply to dual seals (Plans 52, 53, etc.)

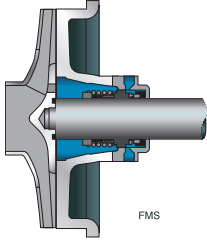

FMS

Same chamber design as FML, but accommodates seals with small gland bolt and gasket circles.

Same seal and flush plan recommendations as for FML.

Single seals with all types of seat mounting configurations can be installed.

FMS design is provided for the convenience of customers with seal standards that include small glands. This design is American-Marsh’s secondary recommendation to the FML.*

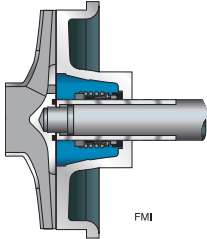

FMI

Same chamber design as FMS, but includes a cast-in integral gland.

- Single internal, flexibly mounted seals. Uses sleeve for seal setting and fast installation.
- “Sanitary-type” applications. Less prone to bacteria build up.

Note: Bypass flush is normally not required.

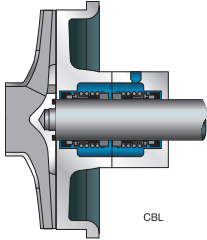

CBL

Oversized, cylindrical step bore design for seals with large gland bolt and gasket circles.

- Dual internal component seals. Isolates the seal chamber from the process. Allows less expensive seal materials. Recommended in tough slurry applications.

Note: Use External Flush Plan 54. Others (i.e., Plans 52, 53) not recommended without close tolerance pumping mechanism.

- Single internal component or cartridge seals when applied with a throat bushing. Usually selected to increase stuffing box pressure above the vapor pressure to avoid cavitation, etc.

Note: Applied with Plan 11, etc.

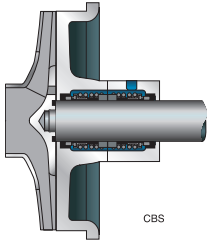

CBS

Cylindrical bore design for packing arrangements and conventional seals with small gland bolt and gasket circles.

- Dual internal component seals. Isolates the seal chamber from the process. Allows less expensive seal materials. Recommended in tough slurry applications. Allows for thermal convection type flush plans; however pumping ring devices are recommended.

Note: Use External Flush Plan 52, 53, 54

- Single internal component or cartridge seals when applied with a throat bushing. Usually selected to increase stuffing box pressure above the vapor pressure to avoid cavitation, etc.
- Usually preferred over the CBL when jacketing is selected for increased effectiveness in cooling or heating.

Note: Applied with Plan 11, etc.

All seal selections perform best when the faces are located directly within the flush plan, particularly if solids, liquors, or slurries are present. Component seals with clamped seat gland designs locate the seal faces reasonably well. Flexibly mounted seat glands should include the vent and drain option to better locate the seal faces. The FML is always the first choice chamber for maximum self-flush path benefits.

Performance Life Cycle Comparison:

AMP Reverse Vane Impeller With Balance Holes

Effects of Wear

Thrust loads decrease as seal chamber gap widens

Chamber pressure increases as gap widens

Effects of Impeller Adjustment To Seal Chamber

Original pressures and loads re-established after adjustments

Repeatable MTBPM cycle life

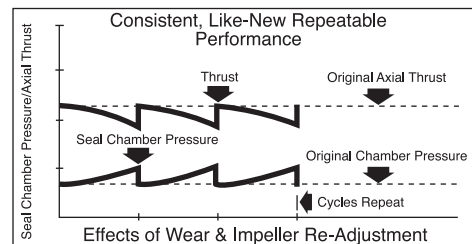

Front Vane Open Style Impeller With Pump Out Vanes

Effects of Wear

Thrust loads increase as seal chamber gap widens

Chamber pressure increases as gap widens

Effects of Impeller Adjustment To Seal Chamber

Chamber pressure and bearing loads increase after each adjustment

Non-repeatable MTBPM cycle life

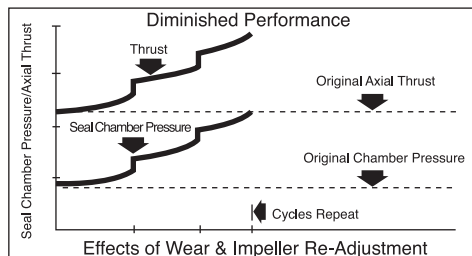

OSD Power Frame

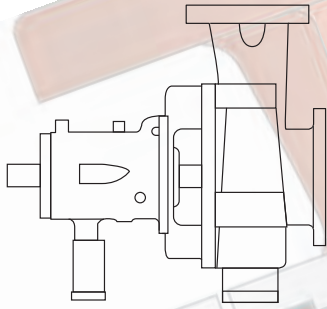

Standard OSD Power Frame Features

- Double row, angular contact outboard/single row, deep groove inboard bearings for excellent axial and radial load support
- Double lip oil seals
- Top mounted vent and oil filler
- Trico oiler
- Large one inch diameter reflective sight glass
- Micro-millimeter impeller adjustment
- Optional oil slinger
- Optional bearing isolators
- Optional magnetic drain plug
- Optional shielded and grease lubricated bearings

Larger Oil Sump

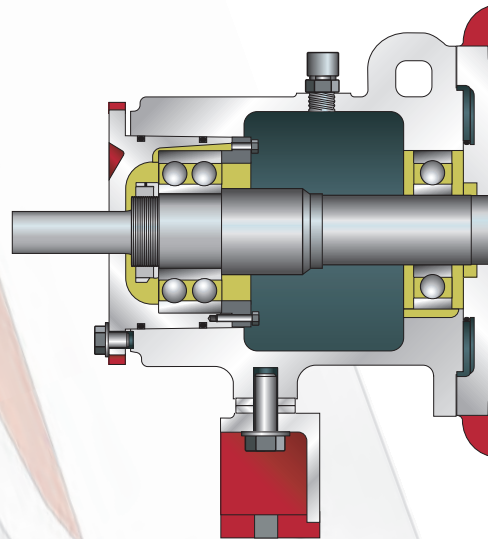

Optional Bearing Housing Cooler

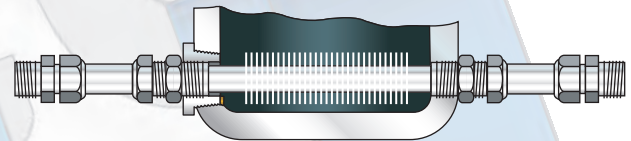

Shaft Details

- 1 Radiused "sled-runner" keyways improve strength at this stress point.
- 2 Offset keyways aid shaft balance.
- 3 Alloy identification on every shaft and sleeve ensures that the right parts go in every time.
- 4 Large radii fillets add strength.
- 5 Accurate machining under bearings ensures perfect bearing fits without vibration or hot running.
- 6 Run-out of <0.001 in (0.03 mm) at mechanical seal allows seal faces to run true.
- 7 Critical surfaces ground to a surface finish of 16u in (0.4 micron) ensure the secondary sealing ability of mechanical seals.
- 8 Steel power ends handle higher horsepower loads than stainless.
- 9 Minimally radiused edges ensure full contact with impeller for reduced run-out.

Group I Shaft

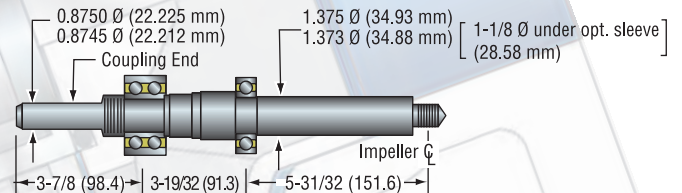

Group II Shaft

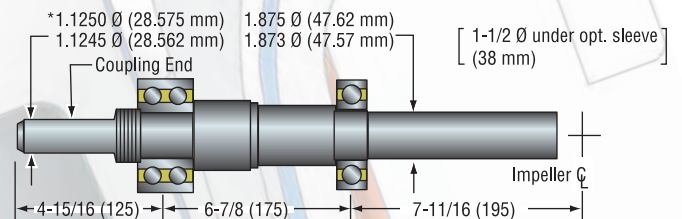

Group III Shaft

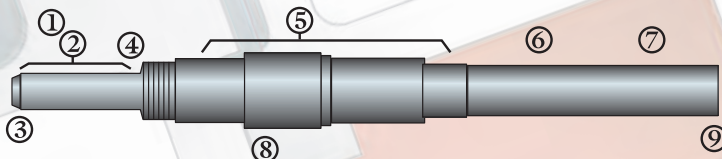
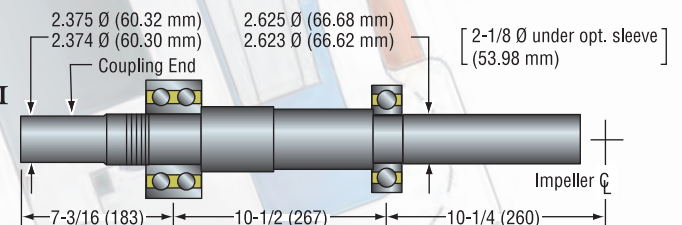

* 4 x 6 -10 pump shaft coupling end 1.5000 Ø (38.100 mm)
1.4995 Ø (38.087 mm)

OSG Power Frame

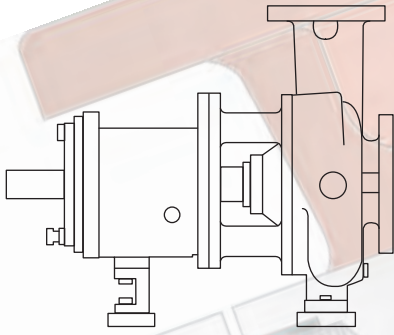

Oversized Oil Sump

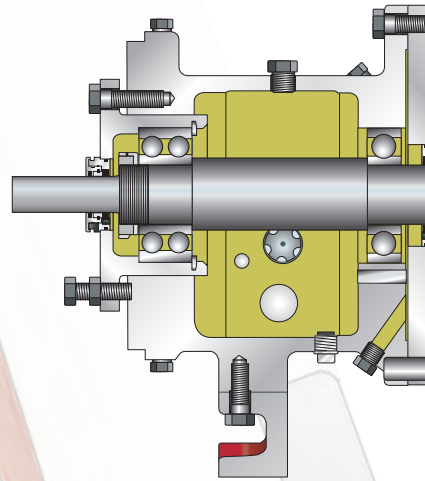

Standard OSG Power Frame Features

- Double row, angular contact outboard/single row, deep groove inboard bearings for excellent axial and radial load support
- Labyrinth bearing isolators at outboard and inboard locations
- Top mounted vent and oil fill port
- Optional Trico oiler
- Large one inch diameter reflective sight glass
- Micro-millimeter impeller adjustment
- Optional oil slinger
- Optional magnetic drain plug
- Optional shielded and grease lubricated bearings

Optional Bearing Housing Cooler



Shaft Details

- 1 Radiused "sled-runner" keyways improve strength at this stress point.
- 2 Offset keyways aid shaft balance.
- 3 Alloy identification on every shaft and sleeve ensures that the right parts go in every time.
- 4 Large radii fillets add strength.
- 5 Accurate machining under bearings ensures perfect bearing fits without vibration or hot running.
- 6 Run-out of <math><0.001\text{ in}</math> (0.03 mm) at mechanical seal allows seal faces to run true.
- 7 Critical surfaces ground to a surface finish of 16u in (0.4 micron) ensure the secondary sealing ability of mechanical seals.
- 8 Steel power ends handle higher horsepower loads than stainless.
- 9 Minimally radiused edges ensure full contact with impeller for reduced run-out.

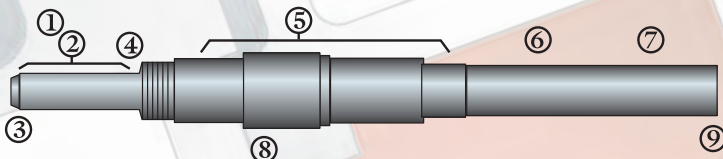

STM

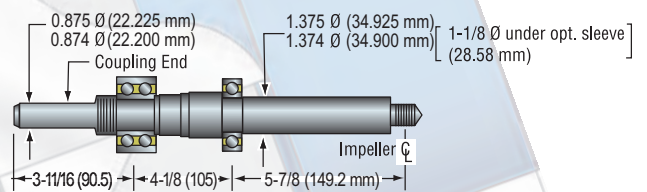

MTM

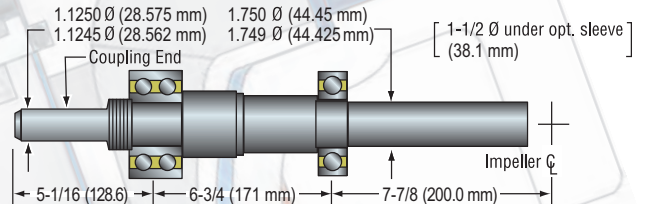

LTM

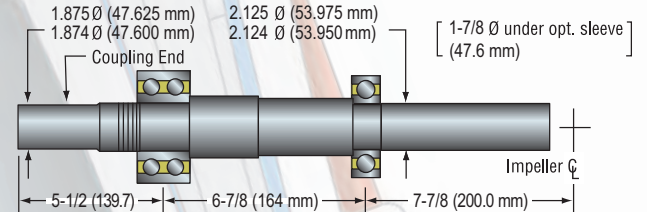

XLTM

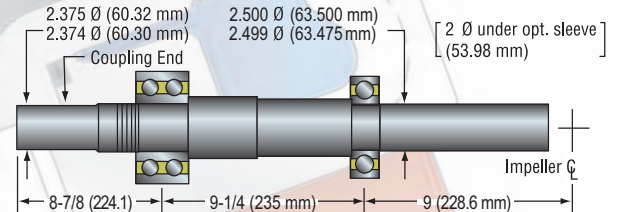

Technical Construction

		Group 1	Group 2	Group 3
Shaft	Diameter at impeller	0.75 (19)	1 (25)	1.5 (38)
	Diameter in Stuffing Box/Seal Chamber			
	(Less Sleeve)	1.125 (29)	1.5 (38)	2.125 (54)
	(With Sleeve)	1.375 (35)	1.875 (48)	2.625 (67)
	Diameter Between Bearings	1.625 (41)	2.438 (62)	3.25 (83)
	Diameter at Coupling	0.875 (22)	1.125 (29)	2.375 (60)
	Overhang	5.969 (152)	7.688 (195)	10.25 (260)
	Maximum Shaft Deflection	0.002 (0.05)		
Shaft Deflection Index (L3/D4)	(Less Sleeve)	59	37	23
	(With Sleeve)	133	90	53
Sleeve	O.D. thru Stuffing Box/Seal Chamber	1.375 (35)	1.875 (48)	2.625 (67)
Bearings	Radial	6207	6310	6314
	Thrust	5306	5310	5314
	Bearing Span	3.594 (91)	6.875 (175)	10.5 (267)
CBL/FML Seal Chamber	Bore	2.875 (73)	3.625 (92)	4.625 (117)
CBS Stuffing Box	Bore	2.125 (54)	2.625 (67)	3.625 (92)
Power Limits	HP (kW) per 100 RPM	1.1 (0.82)	4.3 (3.2)	18.6 (13.9)
Temperature	Maximum Liquid Temperature - Oil/Grease Lubrication w/out Cooling	350° F (177° C)		
	Maximum Liquid Temperature - Oil Lubrication w/High Temp. Option	700° F (370° C)		
Casing	Corrosion Allowance	0.125 (3)		

		ST-M	MT-M	LT-M	LT-M	
Shaft	Diameter at impeller	0.75 (19)	1 (25)	1.25 (32)	1.5 (38)	
	Diameter in Stuffing Box/Seal Chamber					
	(Less Sleeve)	1.375 (35)	1.75 (45)	2.125 (54)	2.5 (64)	
	(With Sleeve)	1.125 (29)	1.5 (38)	1.875 (48)	2 (51)	
	Diameter Between Bearings	1.5 (38)	2.125 (54)	2.5 (64)	3.125 (79)	
	Diameter at Coupling	0.875 (22)	1.125 (29)	1.875 (48)	2.375 (60)	
	Overhang	6.125 (156)	8.375 (213)	8.375 (213)	9.969 (253)	
	Maximum Shaft Deflection	0.002 (0.05)				
	Shaft Deflection Index (L3/D4)	(Less Sleeve)	143	116	48	62
		(With Sleeve)	64	63	29	25
Sleeve	O.D. thru Stuffing Box/Seal Chamber	1.375 (35)	1.75 (45)	2.125 (54)	2.5 (64)	
Bearings	Radial	6207	6309	6311	6313	
	Thrust	3306	3309	7310	3313	
	Bearing Span	4.125 (105)	6.75 (171)	6.875 (164)	9.25 (235)	
CBL/FML Seal Chamber	Bore	2.875 (73)	3.5 (89)	3.875 (98)	4.75 (120)	
CBS Stuffing Box	Bore	2 (51)	2.5 (64)	2.875 (73)	3.375 (86)	
Power Limits	HP (kW) per 100 RPM	1.1 (0.82)	3.4 (2.6)	5.6 (4.2)	14 (10.5)	
Temperature	Maximum Liquid Temperature - Oil/Grease Lubrication without Cooling	350° F (177° C)				
	Maximum Liquid Temperature - Oil Lubrication with High Temp. Option	700° F (370° C)				
Casing	Corrosion Allowance	0.125 (3)				

Mechanical Seals

820 Series Component

Seal De-Rating (Standard Materials)			
Lubricity of Fluid	Gasoline, Kerosene, Oil or Better	x 1.00	
	Aqueous, Water, etc.	x 0.75	
Fluid Temperature	Below 79°C/175°F	x 1.00	
	Above 79°C to 121°C/175°F to 250°F	x 0.90	
	Above 121°C to 177°C/250°F to 350°F	x 0.80	
	Above 177°C/350°F	x 0.65	
Seal Size and Rotational Speed	Seal Size	1800 RPM	3600 RPM
	0.250 to 1.500	x 1.00	x 0.50
	2.125 to 2.500	x 0.92	x 0.46
	2.625 to 3.000	x 0.80	x 0.40
	3.125 to 3.500	x 0.60	x 0.30
	3.625 to 4.000	x 0.51	x 0.25

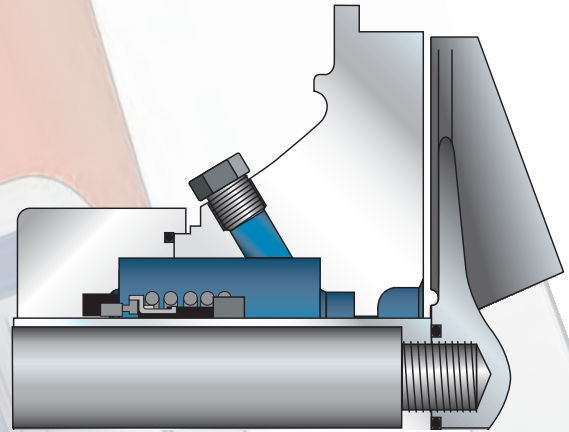

850B Series Balanced Single Cartridge

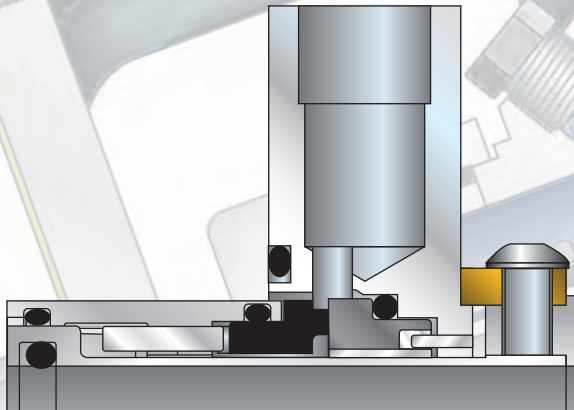

Seal De-Rating (Standard Materials)			
Lubricity of Fluid	Gasoline, Kerosene, Oil or Better	x 1.00	
	Aqueous, Water, etc.	x 0.75	
	Light Hydrocarbons	x 0.60	
Fluid Temperature	Below 79°C/175°F	x 1.00	
	Above 79°C to 121°C/175°F to 250°F	x 0.90	
	Above 121°C to 177°C/250°F to 350°F	x 0.80	
	Above 177°C/350°F	x 0.65	
Seal Size and Rotational Speed	Seal Size	1800 RPM	3600 RPM
	1.000 to 2.000	x 1.00	x 1.00
	2.125 to 2.875	x 0.85	x 0.85
	3.000 to 4.000	x 0.61	x 0.61

860B Series Balanced Double Cartridge

Seal De-Rating (Standard Materials)			
Lubricity of Fluid	Gasoline, Kerosene, Oil or Better	x 1.00	
	Aqueous, Water, etc.	x 0.75	
	Light Hydrocarbons	x 0.60	
Fluid Temperature	Below 79°C/175°F	x 1.00	
	Above 79°C to 121°C/175°F to 250°F	x 0.90	
	Above 121°C to 177°C/250°F to 350°F	x 0.80	
	Above 177°C/350°F	x 0.65	
Seal Size and Rotational Speed	Seal Size	1800 RPM	3600 RPM
	1.000 to 2.000	x 1.00	x 1.00
	2.125 to 2.875	x 0.85	x 0.85
	3.000 to 4.000	x 0.61	x 0.61

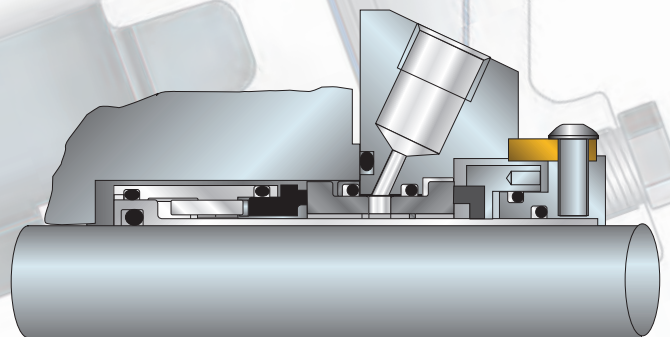

OSD Modular Interchangeability

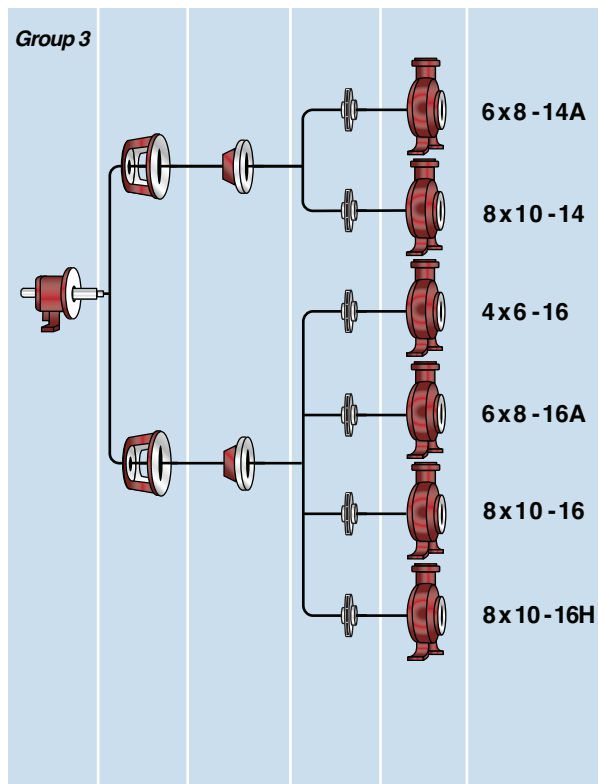
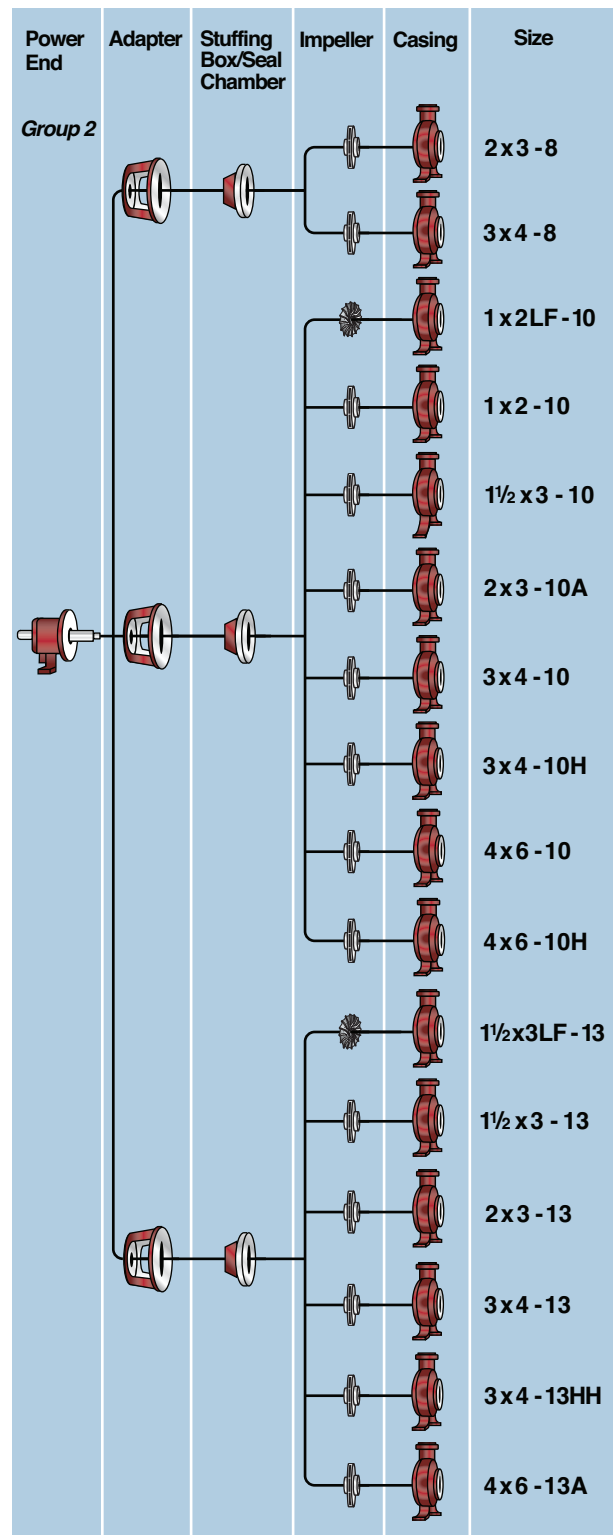
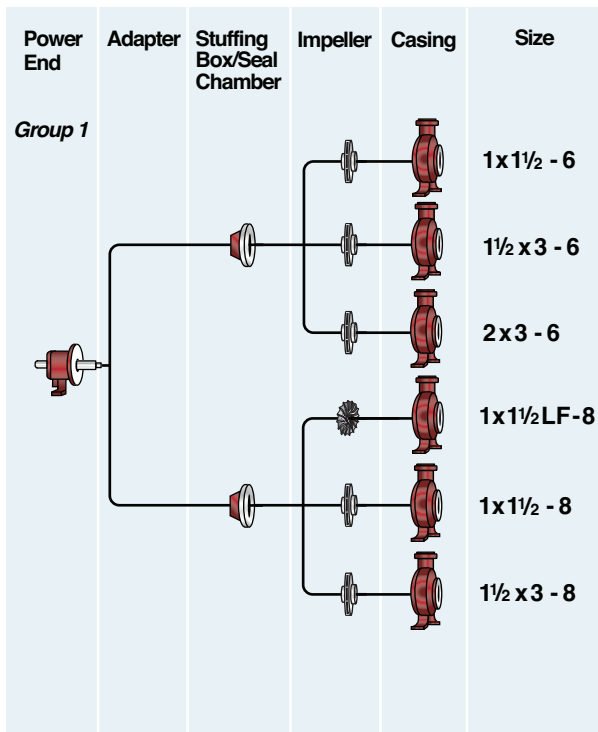

OSG Modular Interchangeability

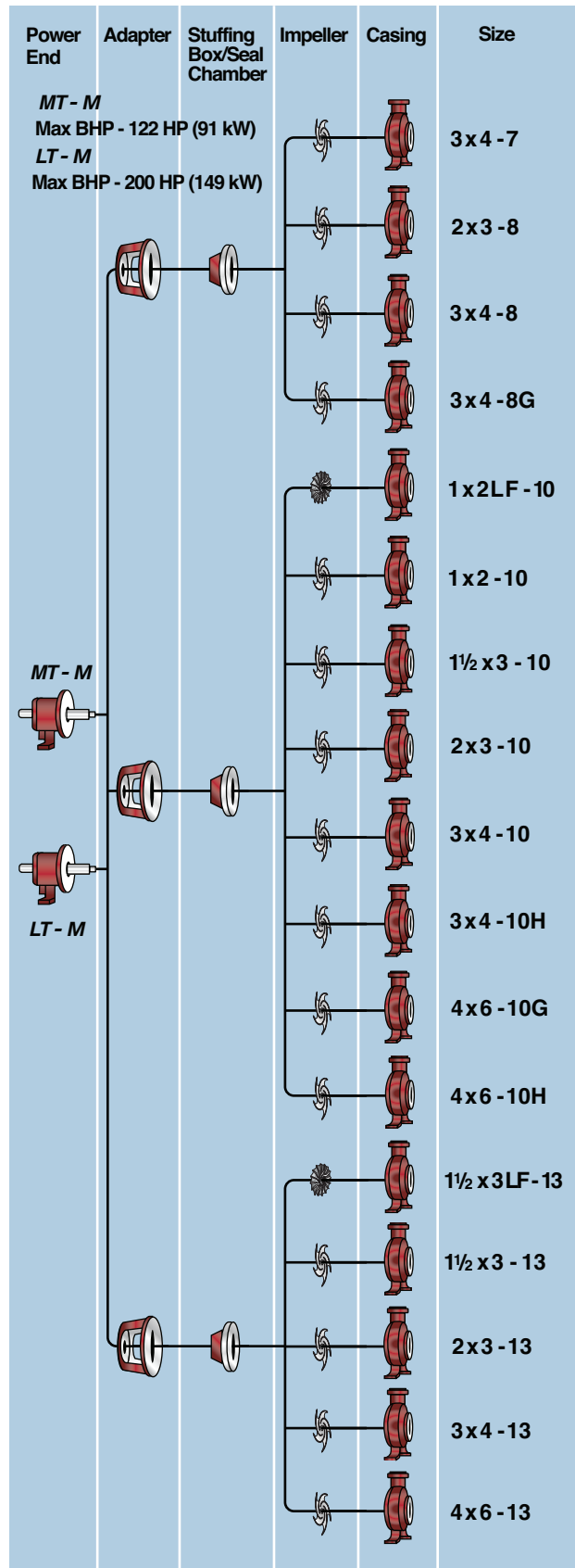
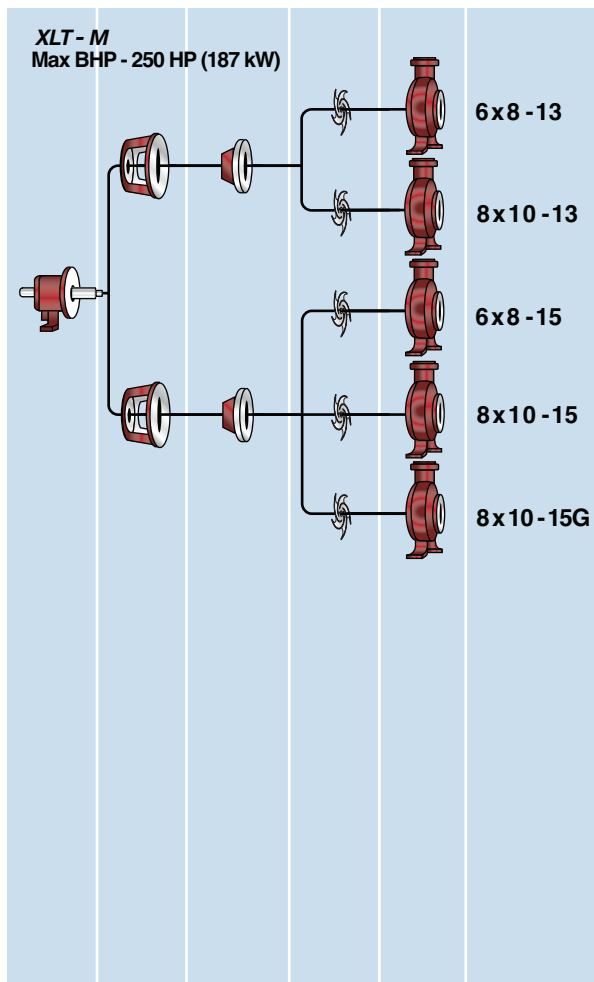
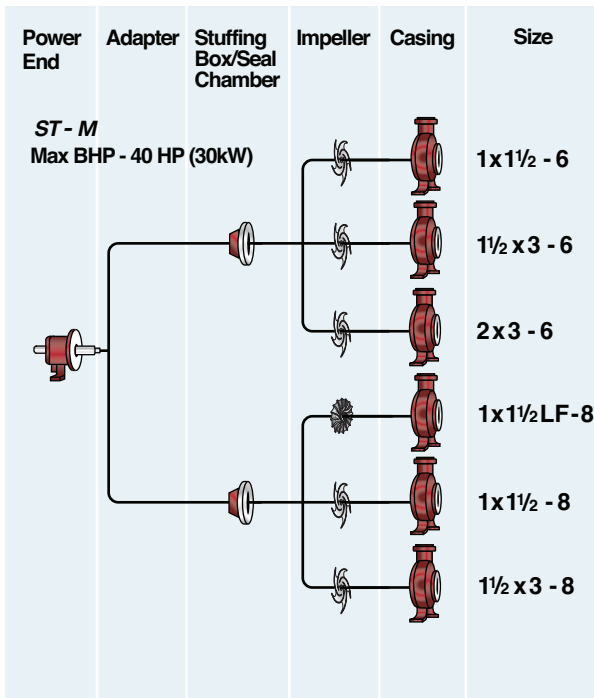

American-Marsh Pumps provides the user dependability and durability. by designing pumps with upgraded, heavier-duty components. Durability by design is always the most cost effective solution.

CASING

The casing fully meets ANSI B73.1M dimensional standards and is designed for back pull-out making service easy. The casing is also provided with additional thickness for corrosion allowance. Surfaces are machined to accurate tolerances in our machining centers. Centerline discharge allows for self-venting casings and cast integral feet provide additional support.

BEARINGS

OSD ANSI pumps feature oversized, oil lubricated bearings designed for long life and minimal maintenance. The inboard bearing is of the single row type and the outboard bearing is of the double row type. The power frame utilizes two double lip oil seals to minimize the entrance of contaminants into the oil. MTBPM is drastically increased by using larger bearings and larger shafts allowing for a smaller shaft deflection index all which extends seal life.

IMPELLER RING

The impeller is investment casted out of customer specified material and is of the exclusive reverse vane design. All impellers are dynamically and hydraulically balanced to meet ANSI B73.1M performance standards. Optional semi-open impellers can be supplied upon request.

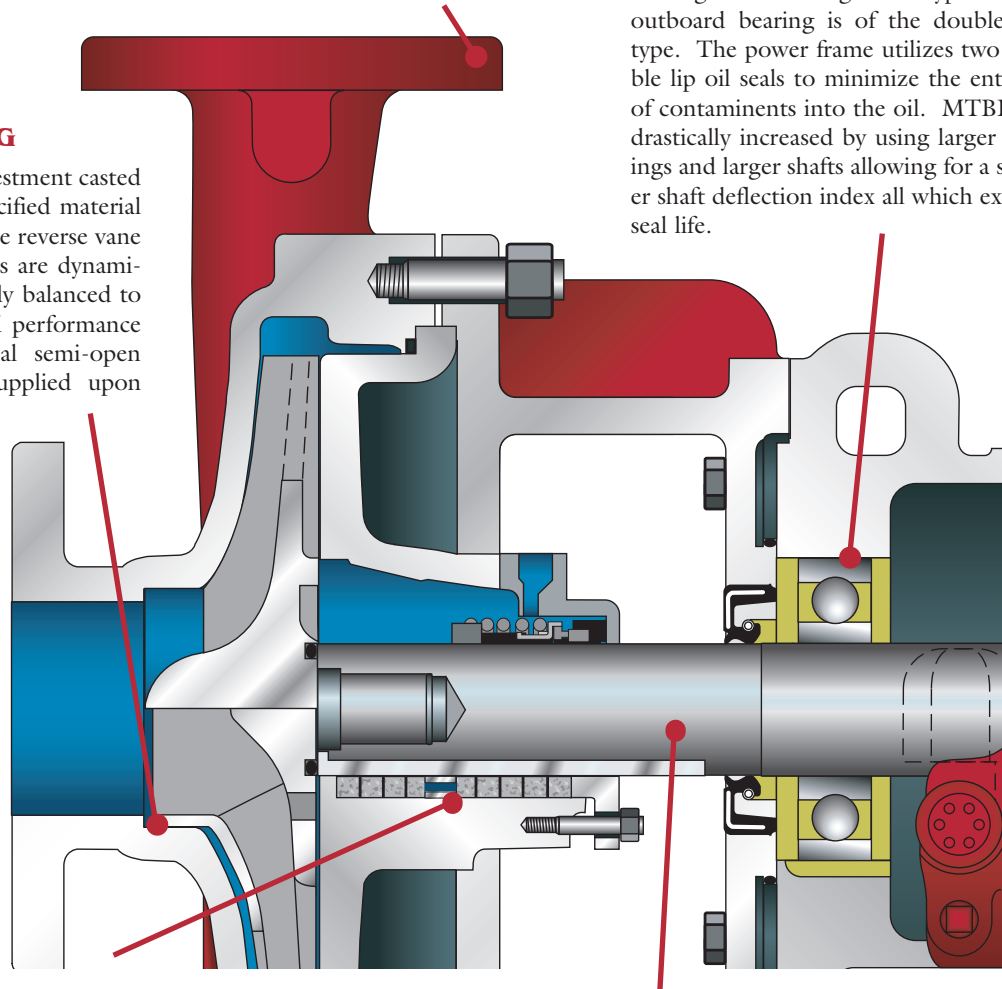

MECHANICAL SEALS/PACKING

OSD ANSI pumps feature five (5) seal chambers designed to meet extreme services found in today's applications. FML, FMS, FMI, CBL & CBS seal chambers offer the enduser a pump and an engineered seal chamber designed to meet specific fluid and temperature requirements.

SHAFTS

Shafts are available in a wide variety of materials and are sized for minimal shaft deflection. Solid, composite and hook sleeve configurations are available upon request.

OTHER PUMP PRODUCTS

SPLIT CASE To 32+'' Discharge 30,000+ GPM, 550'	VERTICAL TURBINE To 42+'' Bowl 85,000+ GPM, 2500+'	MULTI-STAGE To 8'' Discharge 2500+ GPM, 2100'	SELF PRIMER To 12'' Discharge 6400 GPM, 200'	VERTICAL SUMP To 12'' Discharge 9800 GPM, 985'
--------------------------------------------------------------	-----------------------------------------------------------------	------------------------------------------------------------	-----------------------------------------------------------	-------------------------------------------------------------

American-Marsh Pumps
185 Progress Road
Collierville, TN 38017
PH: (800)888-7167
FX: (901)860-2323

Distribution/Service Centers:
Nebraska: 113 South Lincoln Avenue, Hastings, NE 68901 (800)408-7167
California: 3269 East North Building D, Fresno, CA 93725 (800)288-7167
Florida: 2805 Badger Road, Lakeland, FL 33811 (800)444-7167

www.american-marsh.com