

The logo for SPX, featuring the letters 'SP' in a dark grey, bold, sans-serif font, followed by 'X' in a bright green, bold, sans-serif font. A registered trademark symbol (®) is located to the right of the 'X'.

SPX®

A green arrow icon pointing to the right, positioned to the left of the text.

➤ Where Ideas Meet Industry

LIGHTNIN

PULP & PAPERSTOCK AGITATORS

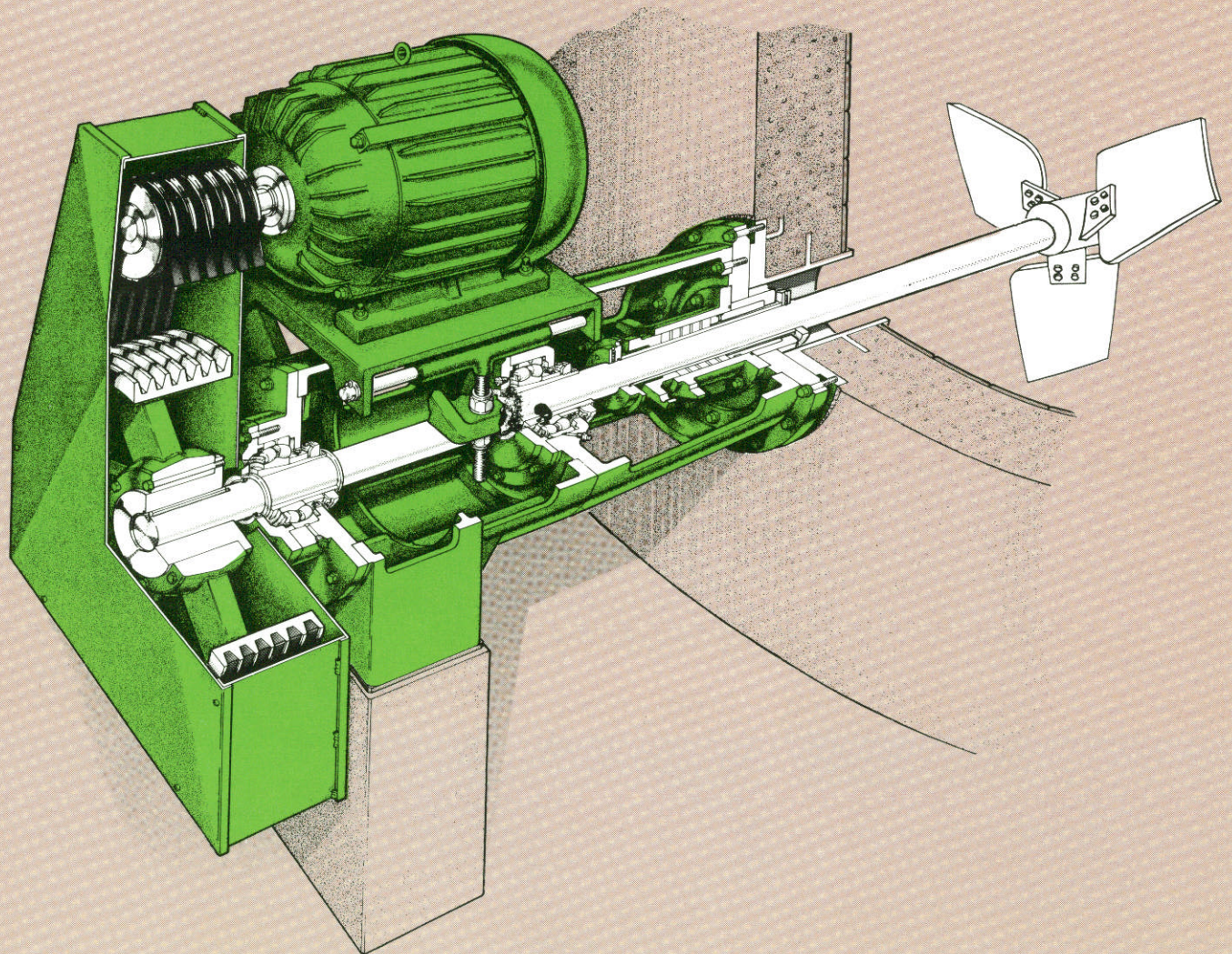
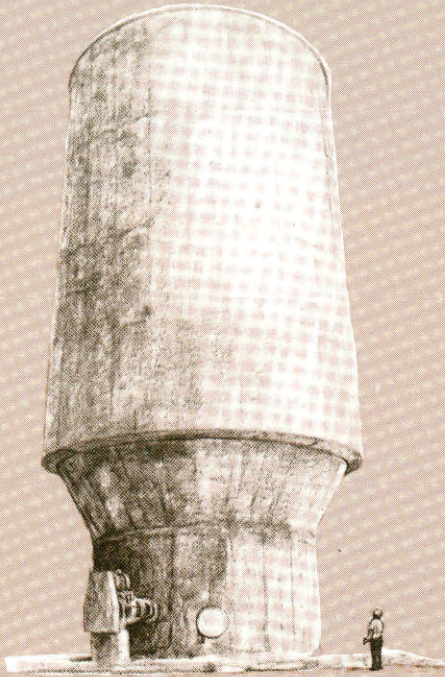

LIGHTNIN heavy duty pulp and paper stock agitators — for guaranteed performance

Every LIGHTNIN stock agitator is backed by the experience gained through 50 years of specialization, with over 10,000 installations throughout the world's pulp and paper mills. LIGHTNIN manufactures a complete range of stock agitators up to 1000 hp. Their engineering recommendations are based upon a full assessment of all relevant factors of the installation,

and result in the selection of the most suitable design of equipment with guaranteed optimum performance — in writing, and at minimum cost. Unusual stock agitation problems are solved either at your mill, or in the LIGHTNIN research laboratories. LIGHTNIN agitators are designed for long trouble-free operation. Many unique features are incorporated to facilitate

maintenance and to reduce downtime to the minimum, an important factor in providing for a high level of mill output. When required, parts and service are readily available from LIGHTNIN, the company that has built an unrivalled reputation on innovative design, quality and service to the pulp and paper industry.

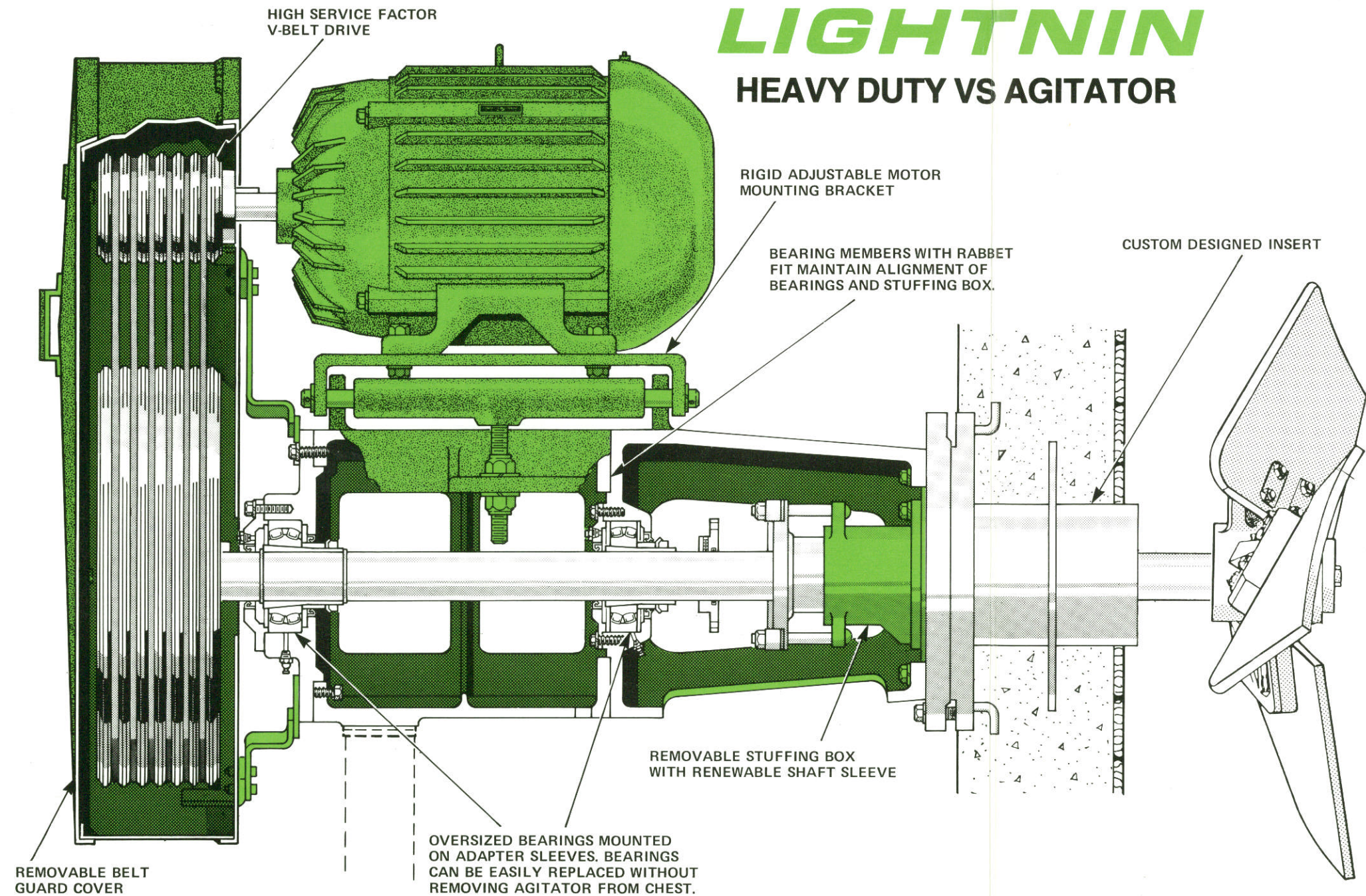

LIGHTNIN originated these agitation techniques

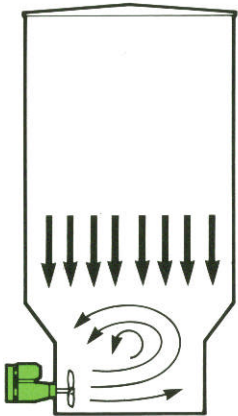

Reduced bottom storage towers and blow tanks

The reduced bottom design was developed by LIGHTNIN to maximize agitator performance, reduce energy costs, and minimize capital construction costs. This efficient design concept has been applied successfully to towers containing over 1000 tons of stock.

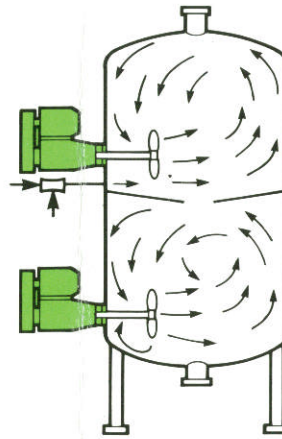

Multi stage high intensity chlorine pre-mixer

The LIGHTNIN chlorine premixing system ensures that each fibre is uniformly contacted with chlorine. Thus a reduction in the size of the chlorination tower is achieved, chemical usage is kept below 5%, and residuals are minimized. For example, three minutes of intensive action in a LIGHTNIN pre-mixer in a 750 ton/day mill reduced the retention time of the chlorine tower to 10 minutes.

Stock chest agitation without midfeather walls

The LIGHTNIN chest agitation system provides complete blending for better uniformity, improved quality and increased production, without the use of costly midfeather walls. Thus chest construction costs are reduced considerably. Very large chests containing over 150 tons of stock at 5% bd consistency have been agitated successfully by the LIGHTNIN system. The performance of existing midfeather chests can be upgraded by the installation of a LIGHTNIN system.

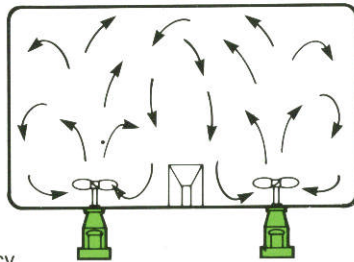

Propeller type couch and press pit pulpers

LIGHTNIN couch and press pit pulpers offer considerable savings in capital cost and maintenance over a horizontal cross shaft arrangement, and the more reliable pulping eliminates plugged stock pumps and costly shutdowns. Press broke of 45% consistency has been repulped from machines over 350 inches wide using LIGHTNIN pulpers.

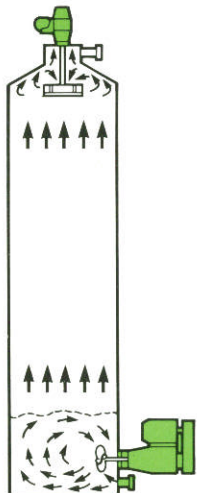
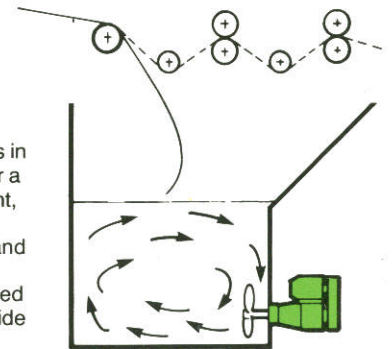

Chlorination towers

The ideal chlorination tower subjects each pulp fibre to the same amount of chemical bleach for the same length of time. This condition is closely achieved with the LIGHTNIN plug flow system which uses a side entry agitator near the bottom of the tower, and a specially designed top entry agitator. A well defined horizontal interface is produced which eliminates the possibility of stock channeling due to inlet hydraulic conditions. The plug flow is maintained throughout the tower with the second agitator providing uniform effluent conditions.

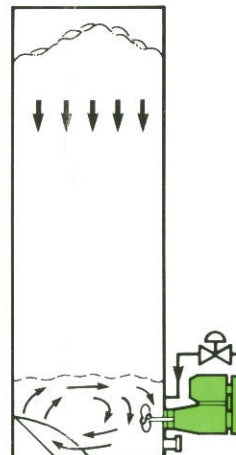

High density downflow bleach towers

Eliminating the costly circulator inserts, centre cone and dilution nozzles of older bleach tower designs, the LIGHTNIN downflow tower has adopted the efficient and economical concepts of the high density storage tower. The LIGHTNIN tower design provides uniform stock consistency with less energy input, eliminates clogged pump suction lines and accurately locates the stock interface. The design concepts have been applied to towers as large as 22 feet in diameter. Typical savings in capital costs in a 750 ton/day bleach plant using the LIGHTNIN design would amount to over \$100,000.

LIGHTNIN[®]
PULP AND PAPER AGITATORS

Members of the Lightnin group are located in Toronto, Canada; Rochester, N.Y., U.S.A.; Mexico, D.F.; Poynton, England; Frameries, Belgium; Paris, France; Frankfurt, Germany; Solna, Sweden; Sydney, Australia.



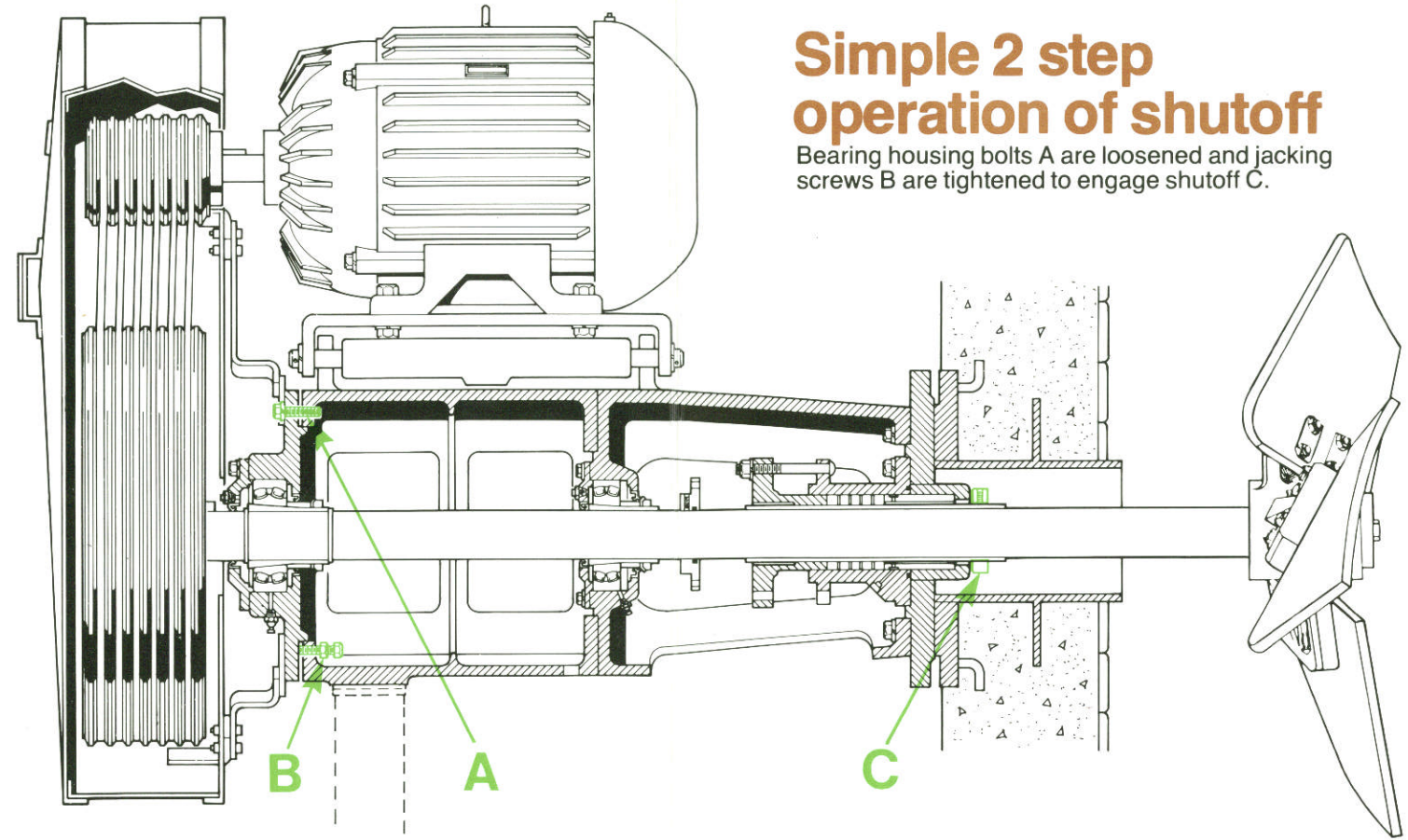

Simple 2 step operation of shutoff

Bearing housing bolts A are loosened and jacking screws B are tightened to engage shutoff C.

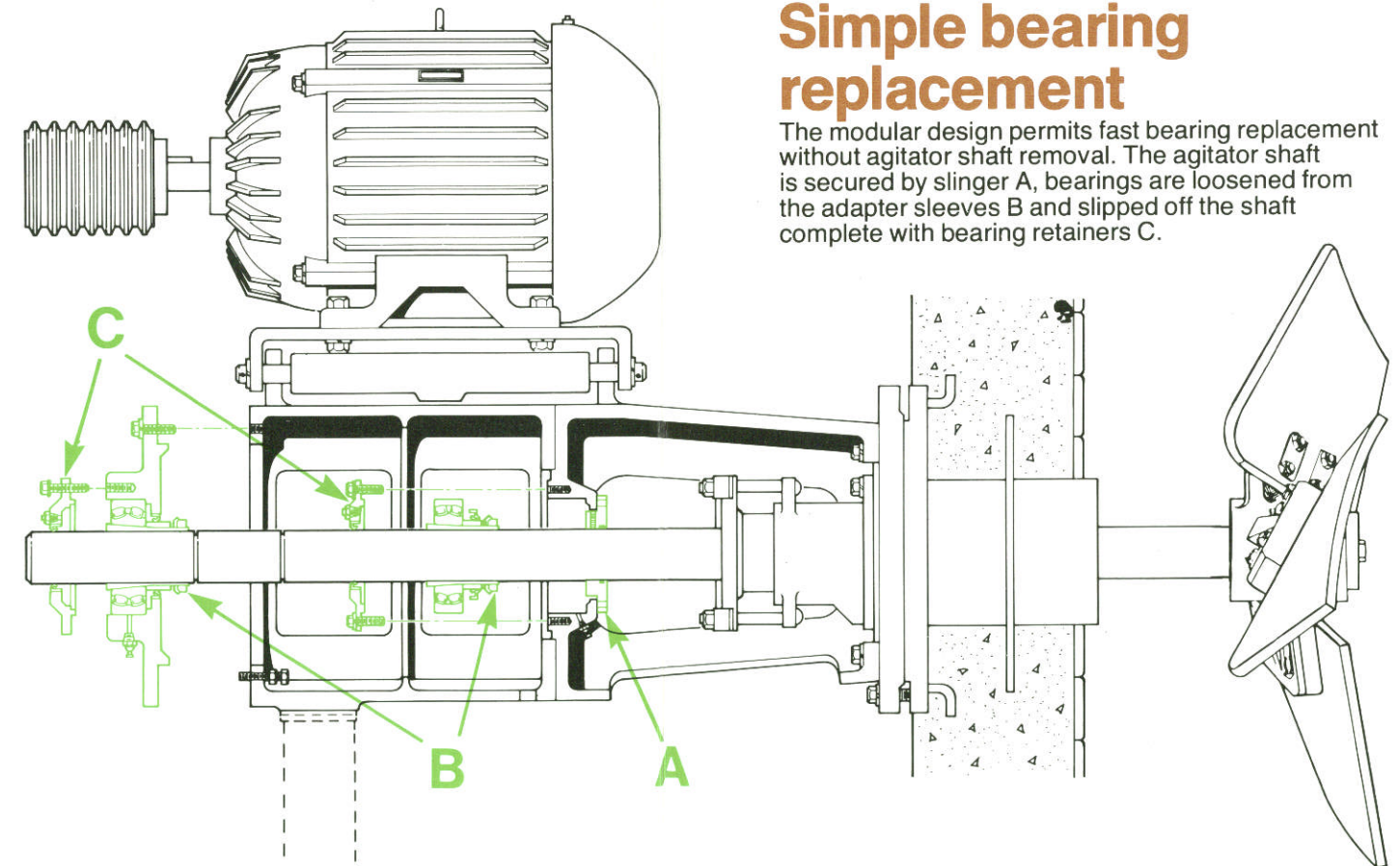

Simple bearing replacement

The modular design permits fast bearing replacement without agitator shaft removal. The agitator shaft is secured by slinger A, bearings are loosened from the adapter sleeves B and slipped off the shaft complete with bearing retainers C.

Heavy duty propellers

LIGHTNIN propellers are computer designed for maximum agitation performance with minimum energy input. The propeller features an extra strong hub and heavy section precision shaped blades with unique reinforcement that provides superior strength without excessive weight. The simple fixed-pitch construction eliminates the risk of loose blades and the need for blade angle adjustment to prevent motor overload, particularly at startup. For special situations, such as small chest openings, LIGHTNIN manufactures a complete range of quality agitators with adjustable-pitch propellers.

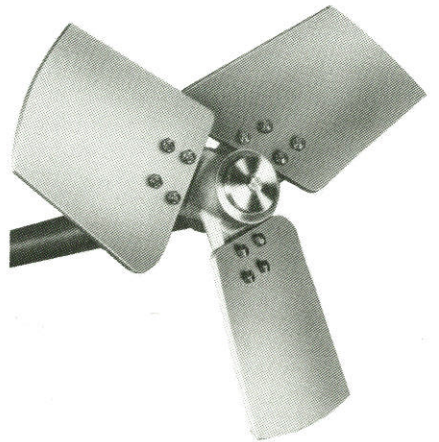

The LIGHTNIN modular stuffing box has been designed specifically for pulp and paper mill applications, and features the simple removal of all components to facilitate inspection and replacement. A flow rotometer ensures the correct volume of flushing water to lubricate and cool the shaft seal. Other packing arrangements are available to suit the site conditions. The LIGHTNIN stuffing box has proven to be long-lasting and easy to maintain under all operating conditions.

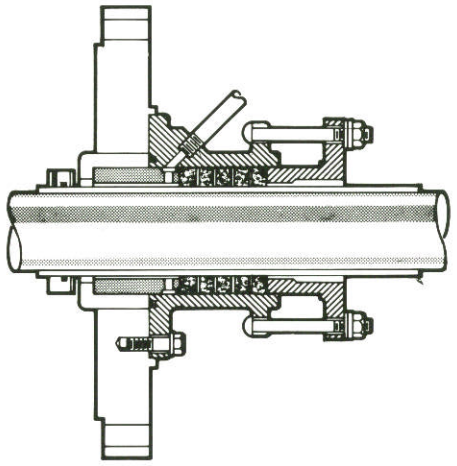

Bearing adapter sleeves

A feature of the LIGHTNIN modular design is the use of adapter sleeves which eliminates the possibility of wear on the agitator shaft itself. All wear takes place on bearing components which can be replaced economically and easily. The shaft does not have to be undercut to retain the bearings in place. The superior design of the LIGHTNIN oversized bearing reduces maintenance costs and keeps agitator downtime to a minimum.

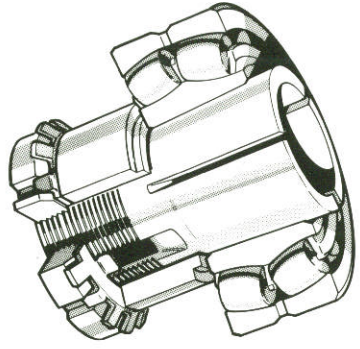



Global Headquarters
13515 Ballantyne Corporate Place
Charlotte, North Carolina 28277
United States

Where Ideas Meet Industry

Where Ideas Meet Industry

www.spx.com